

METRA HIT | 28C

Multimeter, Milliohmmeter and Calibrator

3-349-099-15

7/5.06



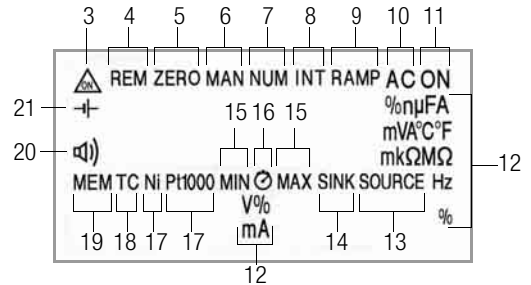

- 1 Display (LCD)
- 2 ON/OFF key, menu functions
Operating mode menu: Changeover to sub-menus / acknowledgement of entries
- 3 DATA/CLEAR key for following functions: save measured value, delete and MIN/MAX
Operating mode menu: Selection of individual menu items against direction of flow, increase values
- 4 MAN/AUTO key for manual measuring range selection
Operating mode menu: Selection of individual menu items in direction of flow, decrease values
- 5 ESC/FUNC key for selecting ranges or functions
Operating mode menu: Exit menu level and return to a higher level, exit parameters configuration without saving data
- 6 **Rotary switch** for measuring and simulation functions
- 7 Connector jacks for calibrator output
- 8 Connector jack for NA5/600 power pack
- 9 Connector jacks for measuring and sensing inputs

Symbols used in the Digital Display

- 1 Main display with decimal point and polarity display
- 2 Auxiliary display with decimal point and polarity display
- 3 : Multimeter in continuous operation, ON blinks at sampling frequency in transmission mode
- 4 REM: Memory mode operation, disappears after interface communication is ended by means of key or switch operation
- 5 ZERO: Zero balancing
- 6 MAN: Manual measuring range selection
- 7 NUM: Numeric entry of output signal
- 8 INT: Interval sequence active
- 9 RAMP: Ramp function active
- 10 AC: Alternating current / voltage
- 11 ON: Calibrator output is active
- 12 Unit of measure (if blinking, refer to chapter 23 on page 39)
- 13 SOURCE: Current source is active
- 14 SINK: Current sink is active
- 15 MIN/MAX: Display of smallest/largest recorded values
- 16 Time data for MIN/MAX function
- 17 Ni/Pt1000: Selected temperature sensor
- 18 TC: Thermocouple
- 19 MEM: Memory mode is active
- 20 : Acoustic signal enabled, beeper is activated for corresponding function
- 21 : Low battery voltage (< 3.5 V), replace batteries

Table of Contents

	Page		Page
1 Safety Features and Precautions	4	16 Dual Mode (Simultaneous Calibration and Measuring)	20
2 Initial Start-Up	5	17 Measuring and Simulation in Percentages	20
3 Selecting Measuring Functions and Measuring Ranges	6	18 Interval Functions, Ramp Functions and Procedures	21
3.1 Automatic Measuring Range Selection	6	18.1 Interval Sequences – INT Function	21
3.2 Manual Measuring Range Selection	6	18.2 Read-Out a Periodic Ramp – RAMP Function	24
4 Triple Digital Display	7	19 Using the Menus – from the Initial InFO Menu to Operating and Measuring Parameters	26
5 Measured Value Storage, “DATA” (Hold & Compare)	7	19.1 Sampling <i>rAtE</i>	29
6 Saving Minimum and Maximum Values “MIN/MAX” with Time Stamp	8	19.2 Saving Measured Values to Memory	29
7 Voltage and Frequency Measurement	9	19.2.1 <i>rAM OCCUP</i> – Querying Memory Occupancy	30
7.1 Voltage Measurement	9	19.2.2 <i>rAM_{CLEAR}</i> – Clearing the Memory	30
7.1.1 Transient Overvoltages	9	19.2.3 <i>TEST_{RAM}</i> – RAM Test Function	30
7.1.2 Voltage Measurements at Above 250 V	10	19.3 Activating the Default Values	30
7.2 Frequency Measurement	10	19.4 Transmission Mode Operation with RS 232 Interface	30
8 Current Measurement	10	20 Accessories	31
9 Resistance, Capacitance and Diode Measurements	11	21 Characteristic Values	32
9.1 Resistance Measurement	11	21.1 Calibrator	32
9.2 Capacitance Measurement	11	21.2 Multimeter	34
9.3 Diode Measurements	12	22 Maintenance	38
10 Milliohm Measurement – 4-Wire Connection	12	22.1 Battery	38
10.1 Continuity Test during Resistance Measurement	12	22.2 5 V Power Pack	38
11 Temperature Measurement	13	22.3 Fuses	39
11.1 Temperature Measurement with Pt100, Pt1000, Ni100 or Ni1000	13	22.4 Housing	39
11.2 Temperature Measurement with Thermocouple and Reference Junction	14	23 Calibrator / Multimeter Messages	39
12 Voltage Simulator, Pulse and Frequency Generator	15	24 Repair and Replacement Parts Service DKD Calibration Lab and Rental Instrument Service	40
12.1 Voltage Simulator	15	25 Warranty	40
12.2 Pulse and Frequency Generator (positive square-wave pulse)	15	26 Product Support	40
13 Resistance Simulation [Ω]	16		
14 Temperature Simulation [°C]	17		
14.1 Temperature Simulation of Resistance Temperature Detectors (2 or 4-wire connection)	17		
14.2 Temperature Simulation of Thermocouples	17		
15 Current Source and Current Sink	19		
15.1 Current Sink – Simulation of a 2-Wire Transmitter	19		
15.2 Current Source	19		

1 Safety Features and Precautions

You have selected an instrument which provides you with a high level of safety.

This instrument fulfills the requirements of the applicable European and national EC guidelines. We confirm this with the CE marking. The relevant declaration of conformity can be obtained from GMC-I Gossen-Metrawatt GmbH.

The instrument is manufactured and tested in accordance with safety regulations IEC 61010-1:2001/DIN EN 61010-1:2001/VDE 0411-1:2002. When used for its intended purpose, safety of the operator, as well as that of the instrument, is assured. However, their safety is not guaranteed, if the instrument is used improperly or handled carelessly.

In order to maintain flawless technical safety conditions, and to assure safe use, it is imperative that you read the operating instructions thoroughly and carefully before placing your instrument into service, and that you follow all instructions contained therein.

Observe the following safety precautions:

- The instrument may only be operated by persons who are capable of recognizing contact hazards and taking the appropriate safety precautions. Contact hazards exist anywhere, where voltages of greater than 33 V RMS may occur.
- Avoid working alone when taking measurements which involve contact hazards. Be certain that a second person is present.



Attention!

Maximum allowable voltage between any given connector jack (9) and earth is equal to 250 V, category II.



Attention!

The calibrator has been designed for safe connection to signal circuits.

Maximum allowable voltage between connector jacks (7) amongst themselves, between (7) and (9), and between (7) and earth is 15 V.

If U_{\max} or I_{\max} is exceeded, the integrated 250 V fuse blows.

- Be prepared for the occurrence of unexpected voltages at devices under test (e.g. defective devices). For example, capacitors may be dangerously charged.
- Make certain that the measurement cables are in flawless condition, e.g. no damage to insulation, no interruptions in cables or plugs etc.
- No measurements may be made with this instrument in electrical circuits with corona discharge (high-voltage).
- Special care is required when measurements are made in HF electrical circuits. Dangerous pulsating voltages may be present.
- Measurements under moist ambient conditions are not permitted.

- Be absolutely certain that the *measuring ranges are not overloaded beyond their allowable capacities*. Limit values can be found in the “Measuring Ranges” table in chapter 21.2, “Multimeter”.
- The mA current measuring ranges are protected with two fuses F1 and F2.
- **The instrument may only be used in power installations if the electrical circuit is protected with a fuse or circuit breaker with a maximum rating of 20 A, and the nominal voltage of the installation does not exceed 250 V.**
- For this reason, **never confuse** the *calibrator* with the *multimeter*.

The jacks labelled in “red” mark the calibrator output. The simulator cables are yellow/black, the measuring cables are red/black.

- When necessary, use a multimeter to make sure that no dangerous contact voltages are present in the signal circuits to which the instrument is to be connected.
- In order to prevent damage to the instrument, observe the *maximum* allowable voltage and current values indicated at the jacks.

With the exception of the resistance simulation and mA SINK operating modes, the connected signal circuits should *not feed any voltage or current* back to the calibrator.

In order to avoid damage to the instrument when interference voltages are applied (within allowable limit values), the mA SINK and mA SOURCE measuring circuit is equipped with a fuse F3, which makes this measuring circuit highly resistive if excessive current should occur in the event of a fault for the duration of overloading.



Warning!

The instrument may not be operated in explosive atmospheres, or connected to intrinsically safe electrical circuits.

Meanings of symbols on the instrument



Warning concerning a source of danger
(Attention: observe documentation!)



Earth



Continuous, doubled or reinforced
insulation

CAT II

Measurement category II device



Indicates EC conformity



This device may not be disposed with the trash.
For further details on the WEEE marking, please
refer to our website www.gossenmetrawatt.com
and enter search key 'WEEE'.

DKD calibration certificate (red seal):



Consecutive number
German Calibration Service - Calibration Laboratory
Registration number
Date of calibration (year-month)

Repair, Parts Replacement and Balancing

When the instrument is opened, voltage conducting parts may be exposed. The instrument must be disconnected from the measuring circuit before the performance of repairs, the replacement of parts or balancing. If balancing, maintenance or repair of a live open instrument is required, this may only be carried out by trained personnel who are familiar with the dangers involved.

Defects and Extraordinary Strains

If it may be assumed that the instrument can no longer be operated safely, it must be removed from service and secured against unintentional use.

Safe operation can no longer be relied upon,

- If the instrument or the test probes are damaged
- If the instrument no longer functions
- After long periods of storage under unfavorable conditions.

2 Initial Start-Up

Battery operation

Be certain to refer to chapter 22.1 regarding correct battery installation.



Attention!

As a result of internal battery voltage monitoring, the instrument may respond as follows if the battery charge level is low:

- Cannot be switched on
- Shuts back down immediately
- Shuts back down in the event of loading at the output.

If this is the case, replace the batteries in accordance with chapter 22.1, or continue work with the power pack if possible.

Operation with mains adapter

(accessory equipment, not included as a standard feature)

During power supply via mains adapter NA5/600, the inserted batteries are cut off electronically so that they may remain in the instrument, see also chapter 22.2. If rechargeable batteries are used, they must be charged outside the instrument.

Switching the Instrument On Manually

- Press the ON/OFF key.
Power-up is acknowledged with a brief acoustic signal. As long as the key is held depressed, all of the segments at the liquid crystal display (LCD) are illuminated. The LCD is shown in the diagram on page 3.
The instrument is ready for use as soon as the key is released.

Switching the Instrument On with a PC

After transmission of a data frame from the PC, the multimeter is switched on. See also chapter 19.4.

Switching the Instrument On Automatically

The multimeter is switched on automatically in the transmission and memory modes.



Note!

Electrical discharge and high frequency interference may cause incorrect displays to appear, and may disable the measuring sequence. In such cases, switch the instrument off and back on again in order to reset. If the problem persists, briefly dislodge the battery from the connector contacts.

Setting Time and Date

See chapter 19 on page 26.

Switching the Instrument Off Manually

- Press and hold the ON/OFF key until OFF appears at the display.

Shutdown is acknowledged with two, brief acoustic signals.

Automatic Shutdown of the Multimeter and the Simulator – “SLEEP MODE”

The instrument is switched off automatically if none of the keys or the rotary switch are activated for approximately 10 minutes. Shutdown is acknowledged with a brief acoustic signal.

Memory or transmission mode: In this case, checking is first performed to determine whether or not the sampling rate has been set to a value of greater than 10 s. The instrument is switched off after 10 minutes, and is reactivated 10 s before data is to be saved to memory (for multimeter as well as simulator). The instrument is then switched back off again.

The instrument can be manually activated with the ON/OFF key in the memory or the transmission mode. After activation of this type, the instrument returns to the “SLEEP MODE”.

If the instrument is to be fully shut down, it must first be activated and then switched off with the ON/OFF key. This ends the memory mode, as well as the transmission mode.

We recommend setting the instrument to continuous operation for **the transmission mode**.

The continuous operation mode is not effected by automatic shutdown.

Automatic Shutdown of the Calibrator

The simulator deactivates the output quantity after 5 minutes of inactivity. 5 minutes later, the instrument is switched off (see “SLEEP MODE”).

Disabling Automatic Shutdown

The instrument can be set to continuous operation.

- Press and hold the ESC/FUNC key and then switch the instrument on by pressing the ON/OFF key. Continuous operation is indicated at the display with the  symbol.

3 Selecting Measuring Functions and Measuring Ranges

3.1 Automatic Measuring Range Selection

The multimeter is equipped with auto-ranging for all measuring ranges, except for temperature measurement, and diode and continuity testing. Auto-ranging is operative as soon as the multimeter is switched on. The instrument automatically selects the measuring range which allows for highest possible resolution for the applied quantity.

When the instrument is switched to frequency measurement, the previously selected voltage measuring range remains active.

The instrument automatically switches to the next highest or next lowest measuring range for the following measured quantities:

Measuring Ranges	Resolution	Switching to next highest range at $\pm(\dots d + 1 d)$	Switching to next lowest range at $\pm(\dots d - 1 d)$
V $\overline{\dots}$, mA $\overline{\dots}$, Ω_2	5 $\frac{3}{4}$	310 000	28 000
V \sim , mA \sim , Hz ¹⁾	4 $\frac{3}{4}$	31 000	2 800
Ω_4 , 3 nF ... 30 μ F	3 $\frac{3}{4}$	3 100	280

¹⁾ 280 digits apply when switching from 300 kHz to 3 kHz.

3.2 Manual Measuring Range Selection

Auto-ranging can be deactivated and measuring ranges can be selected manually in accordance with the following table.

The manual mode is deactivated by pressing and holding the MAN/AUTO key (approx. 1 s), by activating the rotary switch or by switching the instrument off and then back on again.

	Function	Acknowledgement	
		Display	Acoust. Signal
short	Manual mode active: utilized measuring range is fixed	MAN	1 x
short	Range switching sequence for: V: 300 mV \rightarrow 3 V \rightarrow 30 V \rightarrow 300 V \rightarrow 600 V* \rightarrow 300 mV ... Hz: 300 Hz \rightarrow 3 kHz \rightarrow 300 kHz \rightarrow 300 Hz \rightarrow ... mA: 3 mA \rightarrow 30 mA \rightarrow 300 mA \rightarrow 3 mA \rightarrow ... Ω_2 : 30 M Ω \rightarrow 300 Ω \rightarrow 3 k Ω \rightarrow 30 k Ω \rightarrow 300k Ω \rightarrow 3 M Ω \rightarrow 30 M Ω ... F: 3 nF \rightarrow 30 nF \rightarrow 300 nF \rightarrow 3 μ F \rightarrow 30 μ F \rightarrow 3 nF \rightarrow ... \rightarrow 3 V \rightarrow 15 V \rightarrow 3 V \rightarrow ... Ω_4 : 30 m Ω \rightarrow 300 m Ω \rightarrow 3 Ω \rightarrow 30 Ω \rightarrow 30 m Ω \rightarrow ...	MAN	1 x
long	Return to automatic range selection.	—	2 x

* see chapter 7.1.2, “Voltage Measurements at Above 250 V”

Automatic range selection is disabled as long as the MIN/MAX function is active.

4 Triple Digital Display

The three digital displays (1 main display and 2 auxiliary displays) show the measured value with decimal and plus or minus sign. The selected unit of measure and current type are displayed as well. A minus sign appears to the left of the value during the measurement of zero-frequency quantities, if the plus pole of the measured quantity is applied to the "L" input.

"OL" (overload) appears if the measuring range upper limit is exceeded for the following measured quantities:

V DC, I DC, Ω_2 :	309999
V (AC), I (AC), \rightarrow , Hz:	30999
3 nF ... 30 μ F, Ω_4 , \rightarrow short:	3099

The digital display is refreshed at different frequencies for the various measured quantities.

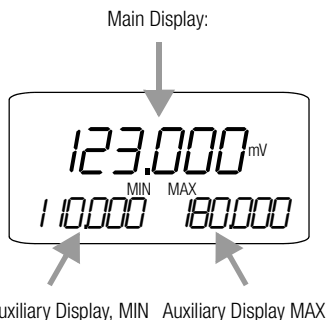

The main display appears immediately after the multimeter is switched on, but the auxiliary display have to be activated by pressing the DATA/CLEAR key. This assures that an undefined existing condition which prevailed when measurement was started is not continuously displayed as a maximum value, e.g. no-load operation.

In the following flow charts the output display is framed with a thicker line.

5 Measured Value Storage, "DATA" (Hold & Compare)

Measurement values can be automatically "frozen" with the DATA (Hold) function. This is useful when, for example, contacting the measuring points with the test probes requires your full attention.

After the measured value has been applied and the corresponding "condition" from the table below has been fulfilled, the measured value appears at the left-hand auxiliary display and 2 acoustic signals are generated. At the same time "MAN" appears and indicates that the measuring range is now set. The test probes can now be removed from the measuring points, and the measured value can be read from the auxiliary display. If the measured value is less than the value

specified in the table, the instrument is reactivated for storage of the next value and "dAtA" blinks at the display.

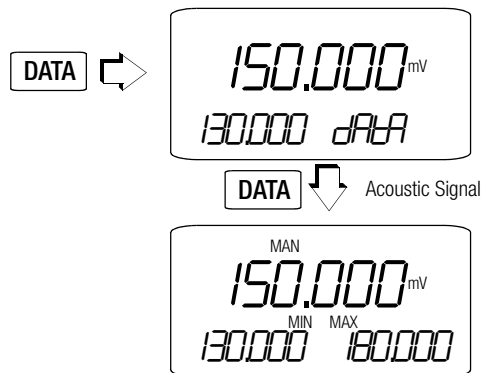

Comparison of measurement values (DATA Compare)

If the newly stored measurement value deviates less than 0.33% from the measuring range, the acoustic signal (DATA Compare) sounds twice. If it deviates more than 0.33% from the measuring range, only a brief signal sounds.

Function DATA	\downarrow DATA	Condition		Response at Instrument		
		Measuring Function	Measured Value	Sub-Display Meas. Value	dAtA	Acoustic Signal
Switch on	brief					brief
Store (stabilized measured value)		V, mA, F, Hz	> 10 % ⁴⁾ of MR	is displayed	is displayed	brief 2x ³⁾
		Ω_2 , \rightarrow ²⁾	OL ⁴⁾			
Reactivate ¹⁾		V, mA, F, Hz	< 10 % ⁴⁾ of MR	stored meas. value	blinks	
		Ω_2 , \rightarrow ²⁾	OL ⁴⁾			
Switch to function MIN/MAX	brief	see Table chapter 6				
Quit	long			is deleted	is deleted	2x

¹⁾ Reactivation results from falling short of specified measured value limits.

²⁾ Valid for continuity testing as well

³⁾ When a measurement value is stored for the first time as a reference value, the acoustic signal sounds twice. For subsequent data hold, two acoustic signals are only generated if the currently frozen value deviates from the first saved value by less than 0.33% of the measuring range, depending upon resolution.

⁴⁾ Exception: 10% at 300 Ω or 3 nF

Key

R = measuring range, MV = measured value

As long as the DATA function is active, the measuring ranges should not be changed manually.

The DATA function is deactivated if the DATA/CLEAR key is pressed and held (approx. 1 s), by turning the rotary switch or by switching the instrument off and back on again.

6 Saving Minimum and Maximum Values "MIN/MAX" with Time Stamp

Minimum and maximum values can be displayed at the auxiliary displays for long-term observation of measured quantities.

- Press the DATA/CLEAR key twice: Current MIN and MAX values appear at the auxiliary displays.

Automatic range selection is disabled as long as the MIN/MAX function is active.

- Press the DATA/CLEAR key once more for a display of the minimum value and the time of its occurrence.
- Press the DATA/CLEAR key once more for a display of the maximum value and the time of its occurrence.

The MIN and MAX values are deleted by pressing and holding the DATA/CLEAR key (approx. 1 s), by turning the rotary switch or by switching the instrument off and back on again.

Function MIN/MAX	↓ DATA	MIN and MAX Measured Values / Time of Measurement	Response from Instrument		
			Main display	Aux. Display	Acoustic Signal
1. Save	2 x short ↓ ↓	are saved	current measured value	MIN and MAX	1 x
2. Save and Display	short ↓ short ↓	are saved		t and MIN	1 x
3. Return to 1	short ↓	are saved	same as 1	same as 1	1 x
Stop	long ↓	are deleted	is deleted	is deleted	2 x



Note!

No new MIN/MAX values are calculated for a period of 2 ... 4 s after the measuring range has been changed (depending upon measuring function), in order to allow measured values to settle in.

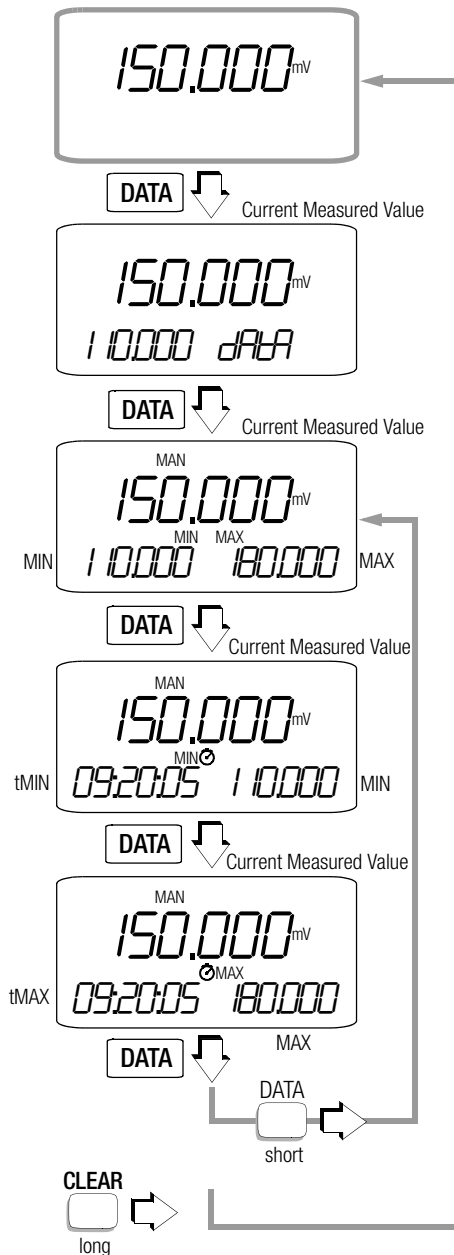

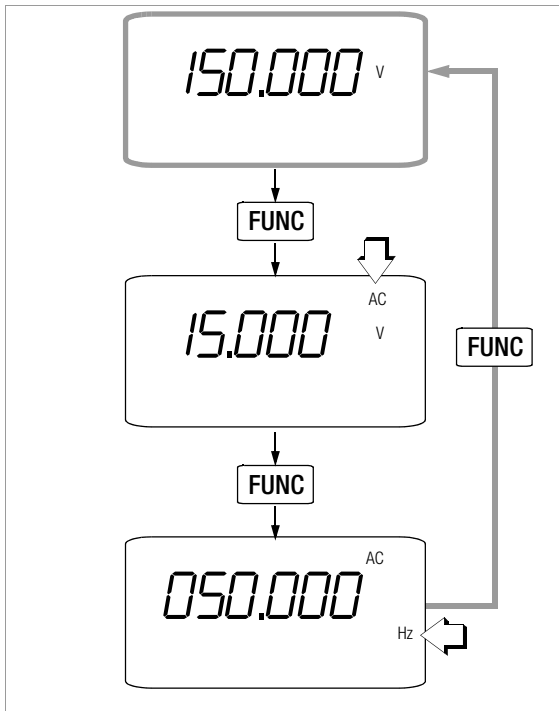

7.1 Voltage Measurement



Attention!

During voltage measurement the measurement cables must not be connected to the calibrator output, otherwise your instrument will be damaged. This operating error and the consequences (repair work) are not covered by warranty!

- Select the V/Hz measuring function with the rotary switch.
- Connect the measurement cables as shown. The “Sense –” connector jack should be grounded.
- Select the current type appropriate for the measured quantity by briefly pressing the ESCIFUNC key. Each time the key is pressed, DC, AC and Hz are alternately selected, and switching is acknowledged with an acoustic signal. If the ESCIFUNC is pressed and held, the display is returned to the start menu. The respective measured quantity is displayed at the LCD. DC voltage measurement is always active immediately after selecting the measuring function with the rotary switch.



Note!

An intermittent acoustic signal warns the operator if the measured value exceeds the upper range limit in the 600 V range (see chapter 7.1.2, “Voltage Measurements at Above 250 V”).



Attention!

Make sure that a current measuring function (“mA”) has not been activated, when the multimeter is connected for voltage measurement! If fuse trip limits are exceeded as a result of operator error, both the operator and the instrument are in danger!

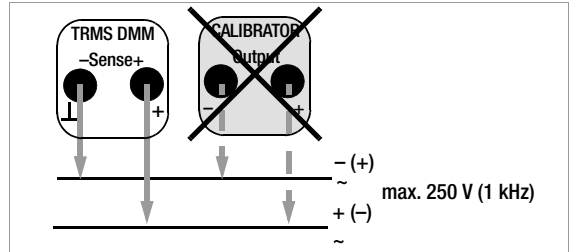

Zero Balancing in the 300 mV/3 V DC Measuring Range

- Select the 300 mV/3 V DC measuring range.
- Plug the measuring cables into the instrument and connect the free ends to each other.
- Press the ESCIFUNC and MANIAUTO keys simultaneously. The instrument acknowledges zero balancing with an acoustic signal, and “000.000” (±1 digit) and the “ZERO” symbol appear at the display. The voltage displayed at the moment the keys are pressed serves as a reference value (max. ±30000 digits). It is automatically subtracted from all subsequent measured values.

If the measuring range is changed (MANIAUTO key), the ZERO function remains active (at the display and in memory).

Zero balancing can be deleted:

- By once again simultaneously pressing and holding the ESCIFUNC and MANIAUTO keys, which is acknowledged with two acoustic signals
- By selecting a new function with the ESCIFUNC key or the rotary switch
- By switching the instrument off.

7.1.1 Transient Overvoltages

The multimeter is protected against transient overvoltages of up to 4 kV with rise times of 1.2, and halftimes of 50 μs. For measurements at transformers or motors with long pulse durations etc., we recommend the use of our KS30 measuring adapter. It provides protection against transient overvoltages of up to 6 kV with rise times of 10, and halftimes of 1000 μs. It has a continuous load capacity of 1200 V_{eff}. Additional influence error caused by the KS30 measuring adapter amounts to approx. –2%.

7.1.2 Voltage Measurements at Above 250 V

The internal device protection is only dimensioned for a maximum voltage of 250 V in measuring category CAT II. However, higher voltages can be measured with a high-voltage probe, e.g. with the HV3¹⁾ or the HV30²⁾ from GMC-I Gossen-Metrawatt GmbH. It is absolutely essential to ground the bonding terminal. Observe all applicable safety precautions!

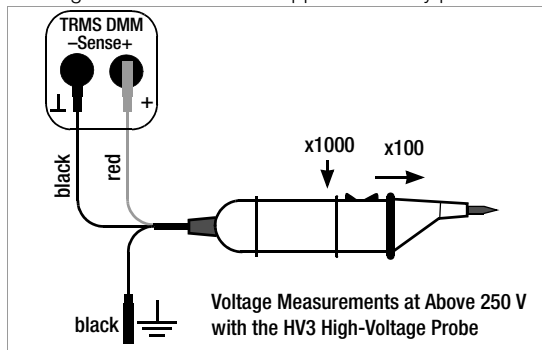

¹⁾ HV3: 3 kV

²⁾ HV30: 30 kV, for direct voltage only

7.2 Frequency Measurement

- ⇨ Select the V/Hz measuring function with the rotary switch.
- ⇨ Apply the measured quantity as described under voltage measurement.
- ⇨ Press the ESCIFUNC key briefly for alternating voltage measurement. Select the measuring range for the voltage amplitude.
- ⇨ Press the ESCIFUNC key briefly once again for frequency measurement. The frequency values appears at the main display. The frequency measuring range can be selected subsequently by pressing MANIAUTO. The lowest measurable frequencies and maximum allowable voltages are included in chapter 21.2, "Multimeter".
- ⇨ The instrument can be switched from frequency measurement back to alternating voltage measurement by pressing the ESCIFUNC key twice. This selection is acknowledged with an acoustic signal. The previously selected voltage measuring range remains active.



Note!

Frequency measurement is only possible if the measuring signal passes through zero (AC coupling).

8 Current Measurement

- ⇨ First disconnect supply power from the measuring circuit or the consuming device, and discharge any included capacitors.
- ⇨ Select the mA range with the rotary switch.

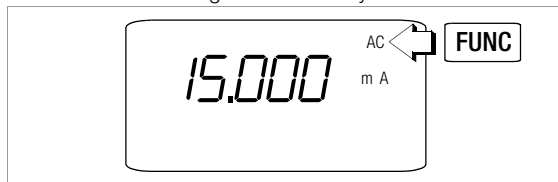

- ⇨ Select the voltage type appropriate for the measured quantity by briefly pressing the ESCIFUNC key. Each time the key is pressed, DC and AC are alternately selected, and switching is acknowledged with an acoustic signal. AC is displayed in order to indicate that AC current has been selected. DC current is always active immediately after range selection with the rotary switch.

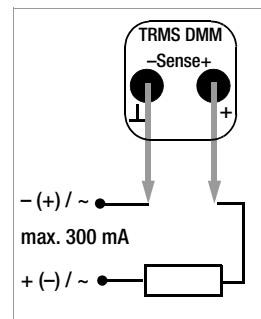

- ⇨ Securely connect the measuring instrument to the consuming device in series as shown (without transfer resistor).

Notes Regarding Current Measurement:

- The instrument may only be used in *power installations* if the electrical circuit is protected with a *fuse* or *circuit breaker* with a maximum rating of 20 A, and the *nominal voltage* of the installation does not exceed 250 V.
- The measuring circuit must be mechanically stable, and must be secured against accidental interruption. Select conductor cross-sections and connectors such that no overheating occurs.
- An intermittent acoustic signal warns the operator if the measured value exceeds upper range limit in the 300 mA measuring range.
- Measuring ranges up to 300 mA are protected against short-circuit current of up to 20 A with two F500 mA/250 V fuses (F1 and F2, see chap. 22.3) link in combination with power diodes. The fuse has a breaking capacity of 1.5 kA/250 V at a nominal voltage of 250 V AC and ohmic load.
- If the fuse blows, eliminate the cause of overload before placing the instrument back into service!
- Refer to chapter 22.3 on page 39 regarding fuse replacement.

9 Resistance, Capacitance and Diode Measurements

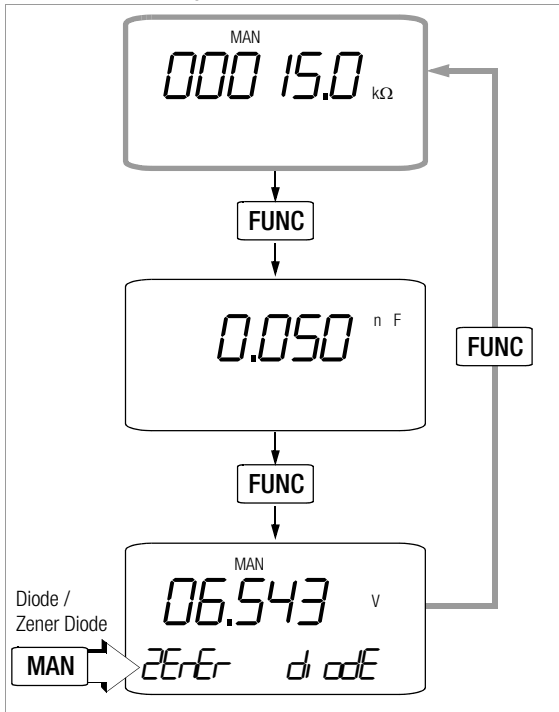

9.1 Resistance Measurement

- ❖ Make sure that the device under test is voltage-free. Interference voltages distort measurement results!
- ❖ Set the rotary switch to “ Ω_2/F ”.
- ❖ Connect the device under test as shown.

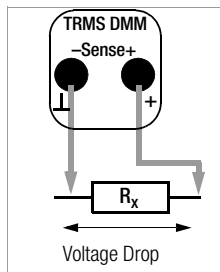

Zero Balancing in the 300 Ω and 3 k Ω Measuring Ranges

Cable and contact resistances can be eliminated for the measurement of small resistance values in the 300 Ω and 3 k Ω ranges by means of zero balancing:

- ❖ Plug the measuring cables into the instrument and connect the free ends to each other.
- ❖ Press the ESC|FUNC and MAN|AUTO keys simultaneously. The instrument acknowledges zero balancing with an acoustic signal, and “000.000 Ω ” and the “ZERO” symbol appear at the display. The resistance value measured at the moment the keys are pressed serves as a reference value (max. 20000 digits). It is automatically subtracted from all subsequent measured values. If the measuring range is changed

(MAN|AUTO key), the ZERO function remains active (at the display and in memory).

- ❖ Zero balancing can be deleted:
 - By once again simultaneously pressing and holding the ESC|FUNC and MAN|AUTO keys, which is acknowledged with two acoustic signals
 - By selecting a new function with the ESC|FUNC key or the rotary switch
 - By switching the instrument off
- See chapter 10.1 regarding continuity testing.

9.2 Capacitance Measurement

- ❖ Make sure that the device under test is voltage-free. Interference voltages distort measurement results!
- ❖ Set rotary switch to “ Ω_2/F ”.
- ❖ Press the ESC|FUNC briefly for capacitance measurement. Unit of measure “F” appears.
- ❖ Connect the (discharged!) device under test to the “ \perp ” and “F” jacks with the measurement cables.

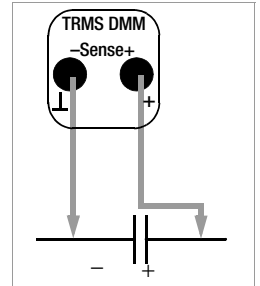

Note!

The “-” pole of polarized capacitors must be connected to the “ \perp ” jack. Resistors and semiconductors which are connected in parallel to the capacitor distort measurement results!

Zero Balancing in the 3 nF and 30 nF Measuring Ranges

Measuring instrument and cable capacitances can be eliminated for the measurement of low value capacitance in the 3 nF and 30 nF ranges by means of zero balancing:

- ❖ Connect the measurement cables to the instrument without a device under test.
- ❖ Press the ESC|FUNC and MAN|AUTO keys simultaneously. The instrument acknowledges zero balancing with an acoustic signal, and “0.000” and the “ZERO” symbol appear at the display. The capacitance value measured at the moment the keys are pressed serves as a reference value (max. 200 digits). It is automatically subtracted from all subsequent measured values.
- If the measuring range is changed (MAN|AUTO key), the ZERO function remains active (at the display and in memory).
- ❖ Zero balancing can be deleted:
 - By once again simultaneously pressing and holding the ESC|FUNC and MAN|AUTO keys, which is acknowledged with two acoustic signals
 - By selecting a new function with the ESC|FUNC key or the rotary switch
 - By switching the instrument off.

9.3 Diode Measurements

- Make sure that the device under test is voltage-free. Interference voltages distort measurement results!
- Set the rotary switch to “ Ω_2/F ”.
- Briefly press the ESC/FUNC key twice for diode measurement. Unit of measure “V” and “*diode*” are then displayed.
- The MAN/AUTO key is used to select either diode or Zener diode measurement (voltage drops of up to 15 V and “*Zener*” are displayed).
- Connect the device under test as shown.

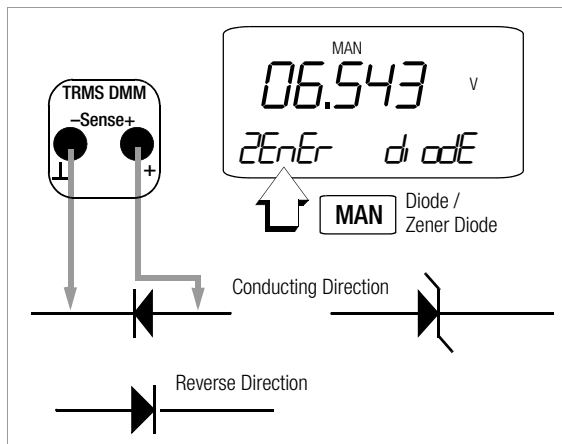

Conducting Direction and Short-Circuit

The instrument displays conducting-state voltage in volts. As long as voltage drop does not exceed the maximum display value of 3 V or 15 V, several series connected components or reference diodes can be tested.

Reverse Direction or Interruption

The measuring instrument indicates overflow: “*OL*” for diode measurements and “*OL*” for Zener diode measurements where $U_d > 3.1$ V or $U_z > 15$ V. Measuring current is always a constant current of approximately 1 mA.



Note!

Resistors and semiconductors which are connected in parallel to the diode distort measurement results!

10 Milliohm Measurement – 4-Wire Connection

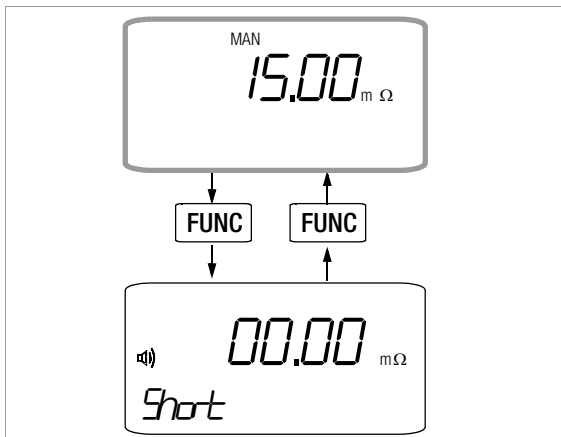

- Make sure that the device under test is voltage-free. Interference voltages distort measurement results!
- Set the rotary switch to “ Ω_4/μ ”.
- Connect the device under test as shown.

Connecting DUTs is simplified through the use of type KC2 (standard wire) or type KC3 (fine wire) Kelvin clips.

The cable resistance of the current cables should be $< 1 \Omega$

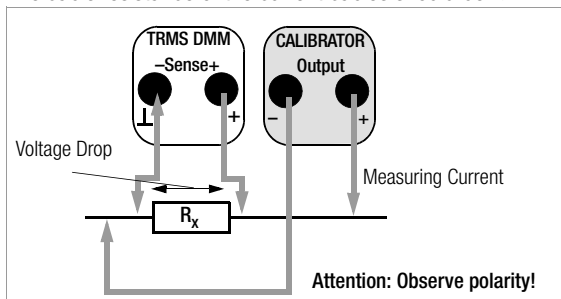

10.1 Continuity Test during Resistance Measurement

If the “acoustic signal μ ” function is activated and the 0 ... 310 Ω measuring range is selected (display: 3 $\frac{3}{4}$ places), a continuous acoustic signal is generated by the instrument within a range of 0 to approx. 10 Ω .

Overflow “*OL*” is displayed where $R_d > 310 \Omega$.

Activating and Deactivating Continuity Testing (acoustic signal)

- Set the rotary switch to “ Ω_4/μ ”.
- Briefly press the ESC/FUNC key. Activation is acknowledged with an acoustic signal. The μ symbol and “*Short*” appear simultaneously at the display.
- Connect the measurement cables to the DUT.
- Continuity testing is deactivated by pressing the ESC/FUNC key once again.

11 Temperature Measurement

- Set the rotary switch to "°C". Press ESC|FUNC to access the selection menu for temperature unit of measure and sensor type. *SEnSOR* and *SELECT* are displayed.
- Press the ESC|FUNC key to select temperature unit of measure °C or °F.
- Select the sensor type (RTD or TC) with the ▽△ keys. If a thermocouple is selected, TC is displayed as well.
- Connect the sensor to the two jacks (see diagram).

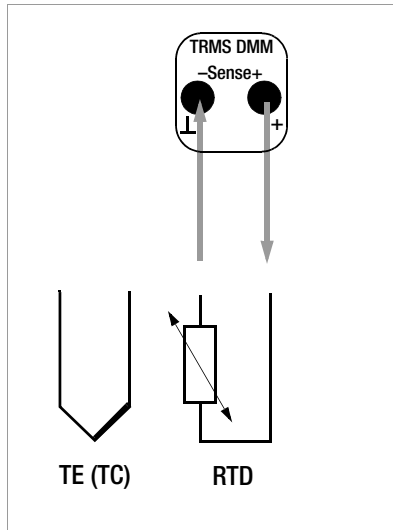

11.1 Temperature Measurement with Pt100, Pt1000, Ni100 or Ni1000

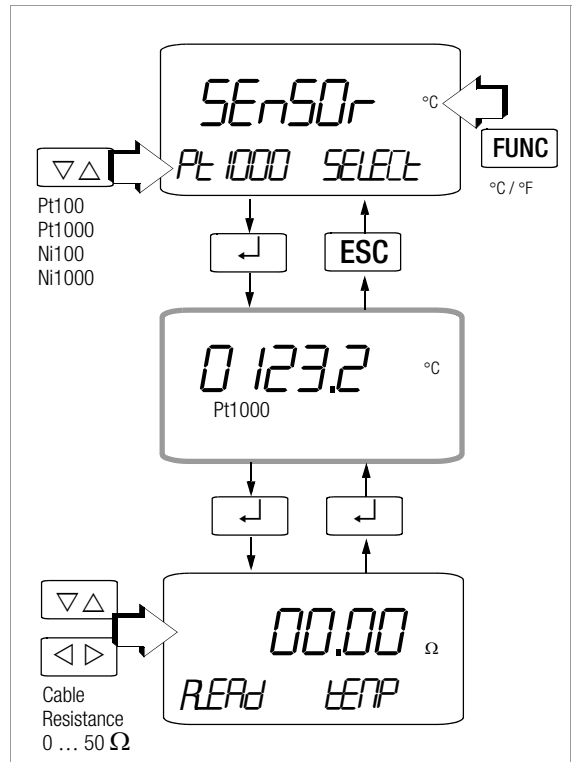

- After selecting a resistance thermometer, the measurement display is accessed by pressing the ↵ key.
- The menu for cable resistance adjustment is opened by pressing the ↵ key once again. *READ* and *tENT* are displayed.
- The decade (i.e. the position of the digit to be changed) is selected with the <|> keys, and the respective digit is set with the ▽△ keys.
- The menu is exited after cable resistance entry is complete, or by pressing the ↵ key, and the measuring display returns. The cable resistance value remains in memory. The default value is 0.1 Ω. Entry is limited to a range of 0 to 50 Ω.

11.2 Temperature Measurement with Thermocouple and Reference Junction

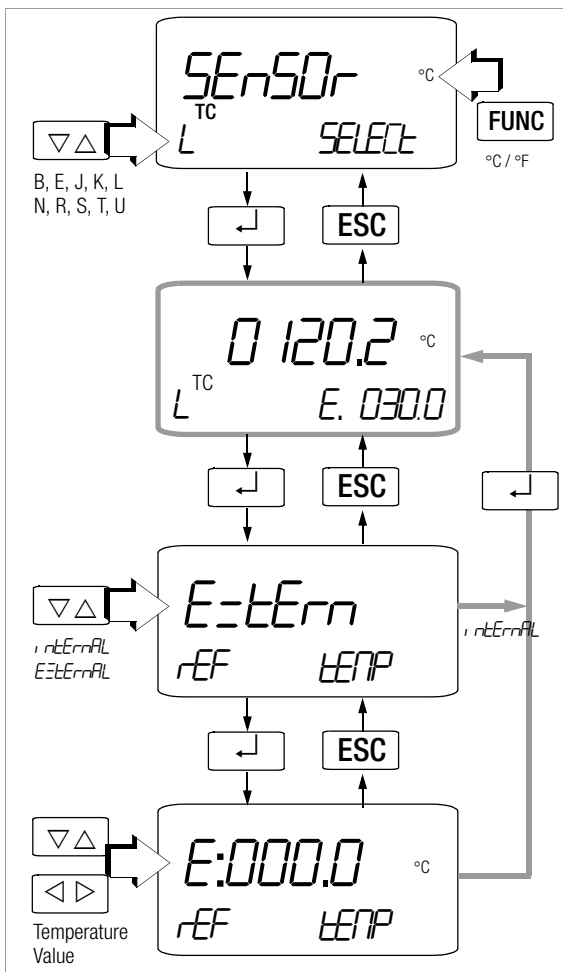

Reference temperature can be either measured with an internal reference junction, or specified with an external reference junction.

- After selecting a thermocouple (SEn50r SELECT menu, MANIAUTO key) the measuring display is accessed with the \leftarrow key. I is displayed for internal or E is displayed for external reference junction in the bottom right-hand field, along with the corresponding temperature.
- The selection menu for internal or external reference junction is accessed here with the \leftarrow key. External (E=LErn) or internal (i nLErn) is selected in the following menu with the $\nabla \Delta$ keys.

- The menu is exited and the instrument is returned to the measuring display after saving the current selection with the \leftarrow key, or without saving the selection by briefly pressing the ESC/FUNC key.
- As long as the external menu is open, the menu for setting the external reference temperature can be accessed by pressing the \leftarrow key. E=LErn and LErNP are displayed. The decade (i.e. the position of the digit to be changed) is selected with the $\leftarrow \triangleright$ keys, and the respective digit is set with the $\nabla \Delta$ keys.
- The menu is exited after reference temperature entry is complete, or by pressing the \leftarrow key, and the measuring display returns.



Note!

The internal reference temperature (internal reference junction temperature) is measured with a temperature sensor in close proximity to the input jacks. It is somewhat higher than room temperature due to internal warming.

12 Voltage Simulator, Pulse and Frequency Generator

The instrument includes the following simulator functions: Direct voltage V DC, frequency f, resistance Ω , temperature °C (for resistance thermometers or thermocouples) and current mA DC.

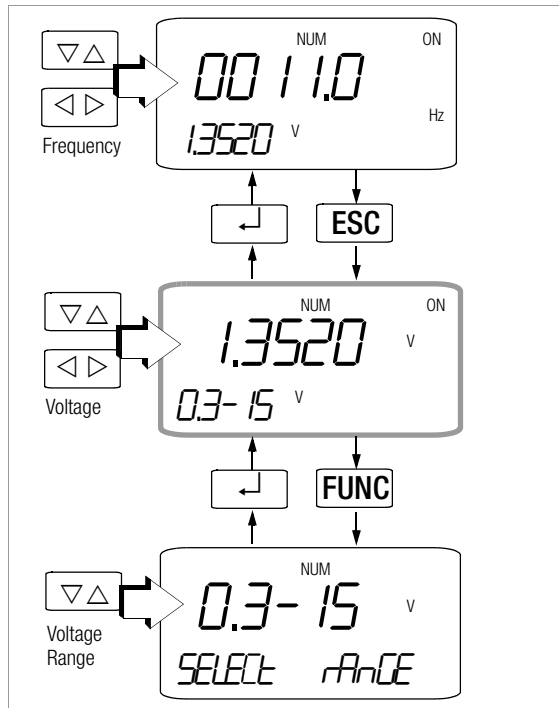

12.1 Voltage Simulator

Voltages can be simulated within the following ranges: 0 ... ± 300 mV, 0 ... 3 V, 0 ... 10 V and 0 ... 15 V.

The resistance of the interconnected circuit should not be any less than 1 k Ω .

- Connect the DUT with the measurement cables as shown.

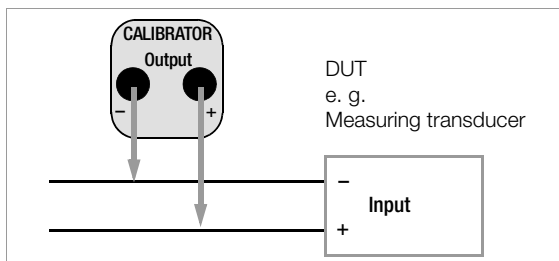

- Select the V/Hz calibration function with the rotary switch.
- Press the ESC/FUNC key if you want to change the selected voltage simulation range. Set the selected digit with the ∇/Δ keys.
- Setting the simulation value: The decade (i.e. the position of the digit to be changed) is selected with the $\triangleleft/\triangleright$ keys, and the respective digit is set with the ∇/Δ keys.

12.2 Pulse and Frequency Generator (positive square-wave pulse)

Voltage and frequency can be generated independent of one another with the frequency generator.

The output signal is a square wave. The resistance of the interconnected circuit should not be any less than 1 k Ω .

- Select the V/Hz calibration function with the rotary switch.
- Setting voltage amplitude (0 ... 15 V): Press the ESC/FUNC key in order to access the menu for setting voltage amplitude. The decade (i.e. the position of the digit to be changed) is selected with the $\triangleleft/\triangleright$ keys, and the respective digit is set with the ∇/Δ keys.
- In order to access the frequency generator menu, press the \lrcorner key repeatedly until the Hz unit of measure is displayed.
- Setting the frequency value (1 ... 1000 Hz): The decade (i.e. the position of the digit to be changed) is selected with the $\triangleleft/\triangleright$ keys, and the respective digit is set with the ∇/Δ keys.

Frequency settings of 29 Hz and greater can only be selected in a limited fashion.



Note!

The following error messages may appear:

"Hi Curr" (high current – current at overload limit) where $I_{max} = 18$ mA,

"out of" and 3 acoustic signals (out of limits – limit value violation) where $I > 30$ mA. The simulator is switched off.



Attention!

Interference voltages must not be applied to the calibrator jacks.

In the event of operating errors, such as the short-term application of a high operating voltage or an interference voltage up to the maximum rated voltage of 250 V, the instrument is protected by a replaceable fuse F3 in the calibrator section.

13 Resistance Simulation [Ω]

Resistance can be simulated by means of 2 or 4-wire connection within the following ranges:

2-wire: 5 ... 2000 Ω

4-wire: 0 ... 2000 Ω.

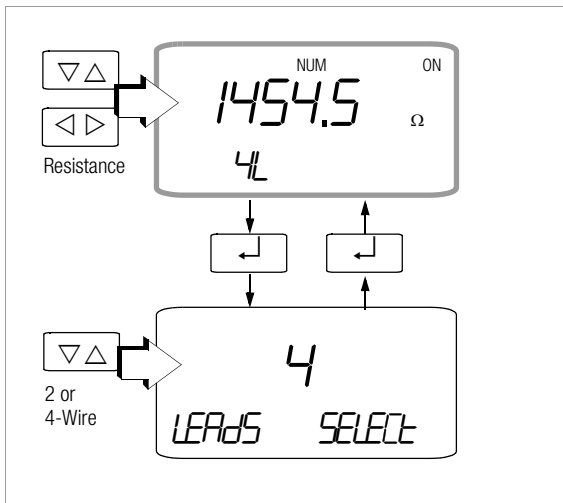

- Connect the DUT with the measurement cables as shown.

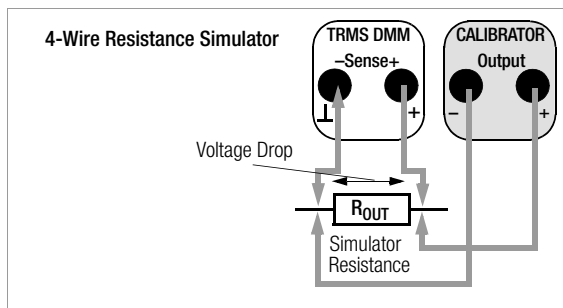
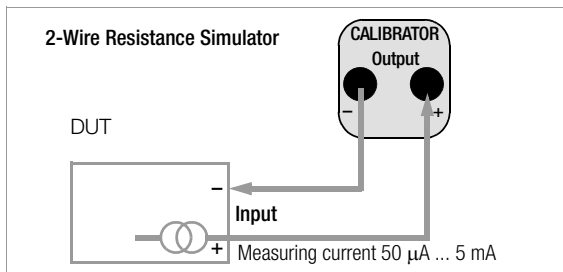

- Select the Ω calibration function with the rotary switch.
- Setting the simulation value:
The decade (i.e. the position of the digit to be changed) is selected with the ◀ ▶ keys, and the respective digit is set with the ▽ ▲ keys.
- 2-wire connection is specified as a default value. Access the selection menu for 2 or 4-wire connection by pressing the ↵ key, and then select the desired type of connection with the ▽ ▲ keys.
- The menu is exited and the instrument is returned to the measuring display after saving the current selection with the ↵ key, or without saving the selection by briefly pressing the ESCIFUNC key.



Note!

The following error messages may appear:

“Hi Curr” (high current – current too high) where

$I > 4,5 \text{ mA}$ and

“Lo Curr” (low current – current too low)

where $I < 40 \mu\text{A}$ (i.e. open jack sockets).



Attention!

Interference voltages must not be applied to the calibrator jacks.

In the event of operating errors, such as the short-term application of a high operating voltage or an interference voltage up to the maximum rated voltage of 250 V, the instrument is protected by a replaceable fuse F3 in the calibrator section.

After applying the measuring current it takes a maximum of 30 ms for the calibrator output to adjust to the specified resistance value.

Incorrect measured values may result in conjunction with DUTs which do not have a steady measuring current (e.g. scanned measuring inputs) if measurement has already been started during setting time. The calibrator cannot be used for such objects.

14 Temperature Simulation [°C]

Resistance temperature detectors (RTD) and Thermocouples (TC) with specified external reference junction temperature can be simulated.

- Select the °C calibration function with the rotary switch.
- Connect the DUT with the measurement cables as shown.
- unit of measure °C or °F can be selected with the ESC/FUNC key.

14.1 Temperature Simulation of Resistance Temperature Detectors (2 or 4-wire connection)

Resistance temperature detectors are simulated by means of resistance values.

- Select either type Pt100, Pt1000, Ni100 or Ni1000 with the ∇/Δ keys for the simulation of an RTD.

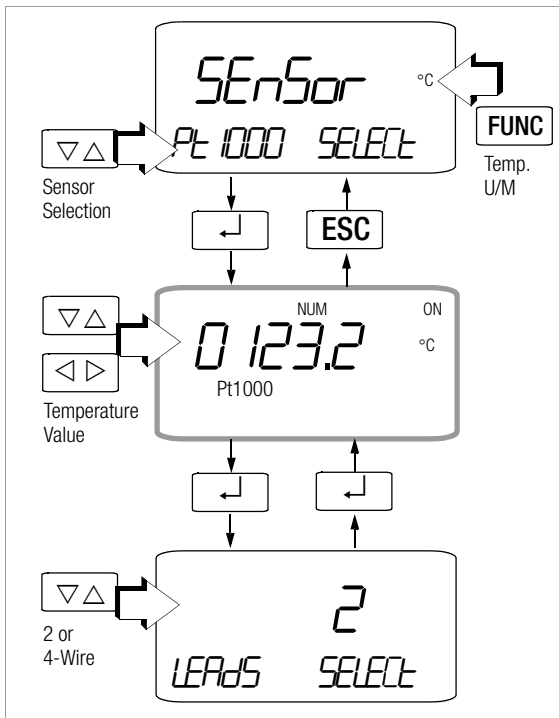

After applying the measuring current it takes a maximum of 30 ms for the calibrator output to adjust to the specified resistance value.

Incorrect measured values may result in conjunction with DUTs which do not have a steady measuring current (e.g. scanned measuring inputs) if measurement has already been started during setting time. The calibrator cannot be used for such objects.

14.2 Temperature Simulation of Thermocouples

Thermocouples are simulated by means of voltage. Internal or external temperature compensation is possible.

- Select either type B, E, J, K, L, N, R, S, T or U with the ∇/Δ keys for the simulation of a thermocouple.
- External reference temperature entry is accessed with the \downarrow key. The entry position at the far left blinks. Numerals are entered with the ∇/Δ keys. Each selection is acknowledged with the \downarrow key and the cursor is then advanced one place to the right.
- The display is returned to the start menu by acknowledging the selection at the far right with the \downarrow key, or by activating the ESC/FUNC key.

Function Description and Applications

10 different types of thermocouples can be selected, and can be simulated within the temperature ranges specified by IEC/DIN.

Selection can be made between an internally measured reference junction temperature, or numeric entry of an external reference junction temperature within a range of -30 to +40 °C.

Important Notes Regarding the Reference Temperature

The internal reference temperature is measured continuously with the help of an integrated temperature sensor, which is thermally coupled to the " \downarrow " jack.

The reference temperature is generally measured at the thermocouple connector jack for devices under test with a thermocouple measuring input.

The two measurements may yield different results, and differences are registered as errors during thermocouple simulation. The following methods help to reduce this error:

- The device under test is connected to the jacks at the calibrator with equalizing leads for the thermocouple to be simulated.
- The temperature of the thermocouple connector jack at the device under test is measured with a precision temperature measuring instrument, and the resulting value is entered to the calibrator as a reference temperature. The calibrator and the device under test are connected with copper wire.

Otherwise, the external reference temperature is entered in all cases where temperature measurement at the device under test is accomplished by means of a thermostatic reference junction (end of the thermocouple equalizing lead).



Attention!

Interference voltages must not be applied to the calibrator jacks.

In the event of operating errors, such as the short-term application of a high operating voltage or an interference voltage up to the maximum rated voltage of 250 V, the instrument is protected by a replaceable fuse F3 in the calibrator section.

Example ad a) Internal Reference Junction

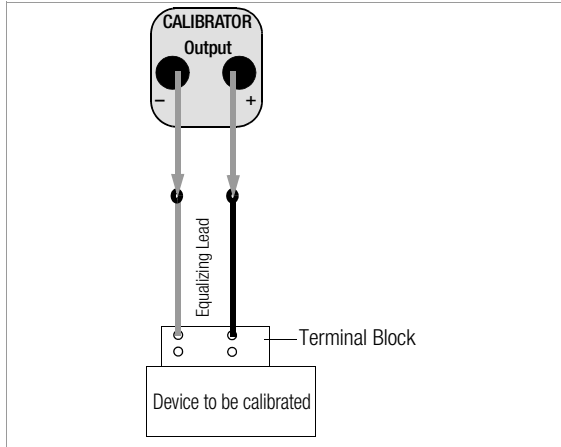

Example ad b) External Reference Junction

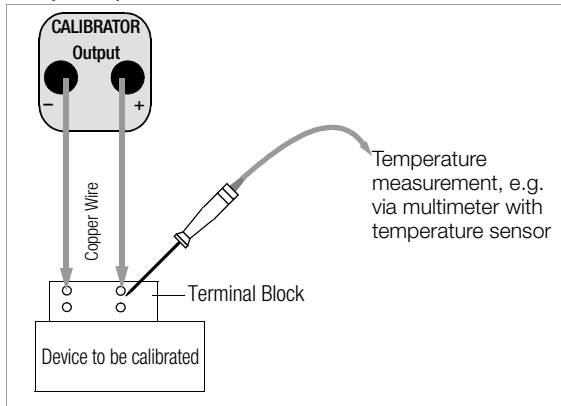

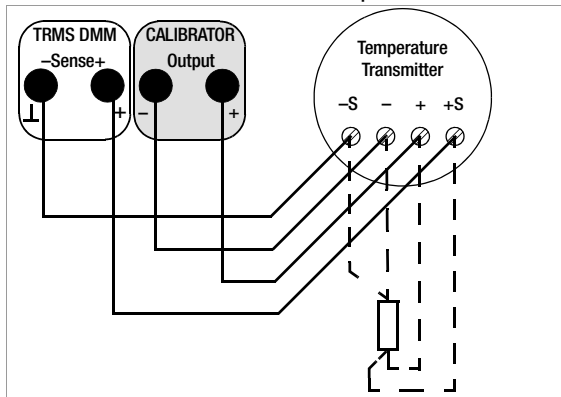

Connection and Simulation of a 4-Wire Temperature Sensor

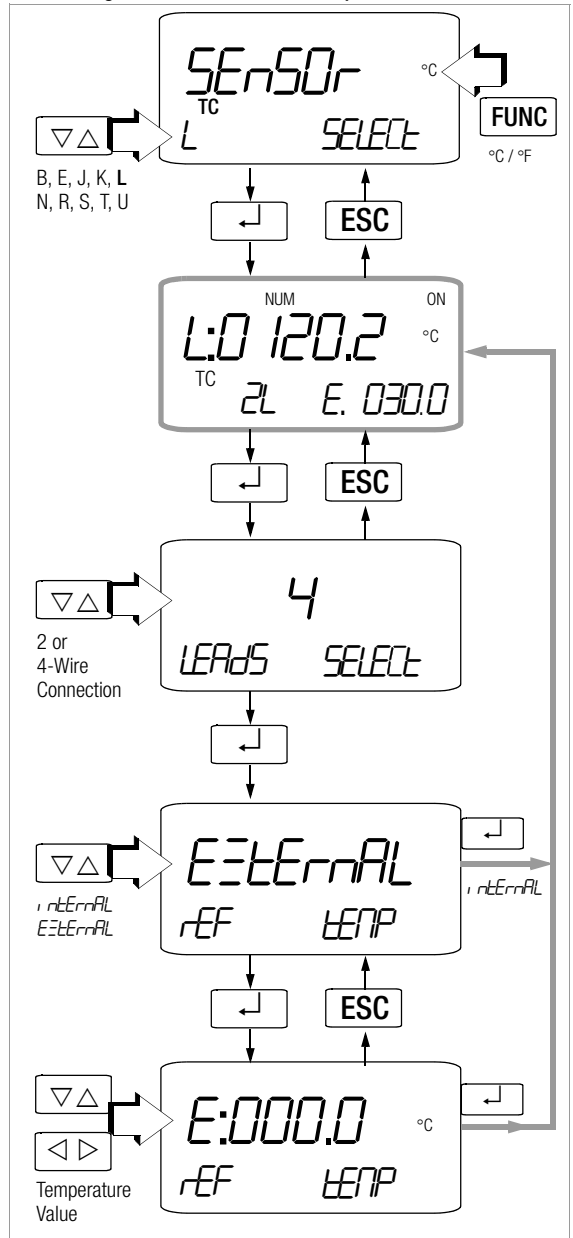

Selecting Sensor Type, if 2- or 4-Wire Connection, Setting the Temperature Simulation Value and Entering the External Reference Temperature



15 Current Source and Current Sink

- Connect the device under test with the measurement cables.
- Select the mA current sink  calibration function or mA current source  with the rotary switch.
- Press Esc until you enter the range selection menu.
- Select the desired range: 0 ... 20 mA, 4 ... 20 mA or 0 ... 24 mA, with the ∇/Δ keys.
- Press the \hookrightarrow key to enter the output menu.
- Setting the simulation value:
The decade (i.e. the position of the digit to be changed) is selected with the $\triangleleft/\triangleright$ keys, and the respective digit is set with the ∇/Δ keys.
ON indicates that the current source is active.

15.1 Current Sink – Simulation of a 2-Wire Transmitter

A current sink (0 ... 24 mA) or current loop load can be simulated with this function. The calibrator regulates the current, which flows via the calibrator jacks from an external power supply, independent of direct voltage applied to the jacks (4 ... 27 V). The calibrator varies the internal resistance such that the adjusted current value flows.

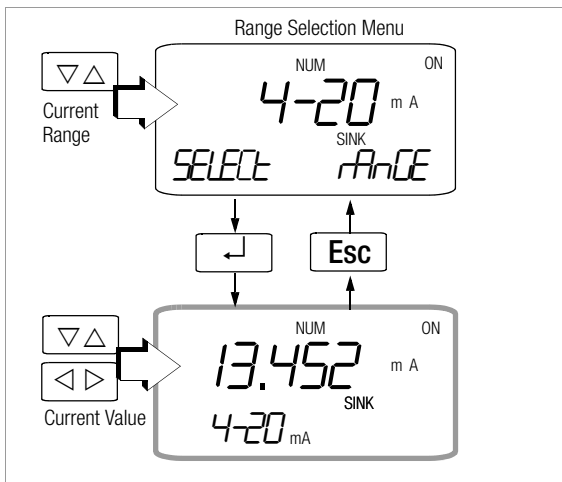

Note!

The latest adjusted simulator range is stored to memory.

Voltage at the calibrator jacks may not exceed 27 V in the current sink operating mode, because thermal overload would otherwise occur and the fuse F3 would blow.

LoVOLT appears at the display where the voltage is too low.

Example of a 2-Wire Transmitter Measuring Circuit

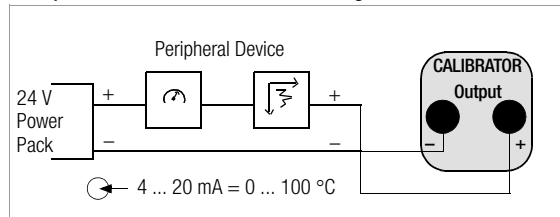

15.2 Current Source

Internal supply power is used for the simulation of a current source.

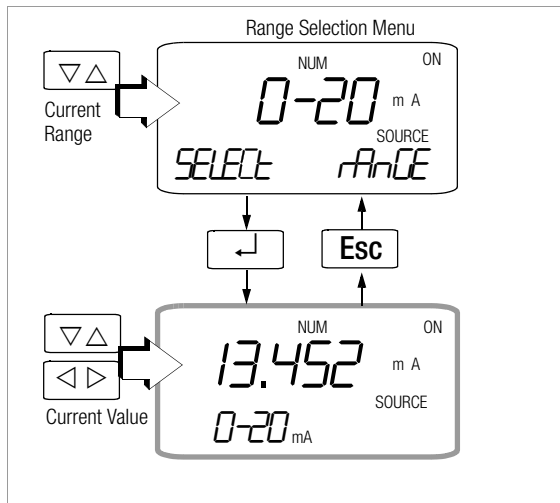

Note!

The internal control circuit of the current source is monitored: if voltage drops by more than 20 V at the external burden or if the current circuit is interrupted, „Hi burd“ appears at the display.



Attention!

In this operating mode interference voltages must not be applied to the calibrator jacks.

In the event of operating errors, such as the short-term application of a high operating voltage or an interference voltage up to the maximum rated voltage of 250 V, the instrument is protected by a replaceable fuse F3 in the calibrator section.

16 Dual Mode (Simultaneous Calibration and Measuring)

All simulator functions can be activated and the corresponding output quantity (U or I) can be measured simultaneously in the dual mode.



Attention!

The device under test and the simulator must be electrically isolated.

Exception where electrical isolation is concerned: simulation and measurement of voltage without an external circuit. For example, if voltage output needs to be tested, you only need to connect the Calibrator+ and Sense+ sockets to each other, because the Calibrator- and Sense- jacks are connected internally.

Activating the Dual Mode

- Select a measuring function: V or mA.
- Press and hold the ESCIFUNC key and select the simulator function with the rotary switch.
- Set the simulation value with the Δ ∇ keys in the main display.

The respective measured values appear in the left-hand auxiliary display.

- Exit the “Dual Mode” by pressing the ESCIFUNC key, or by turning the rotary switch.

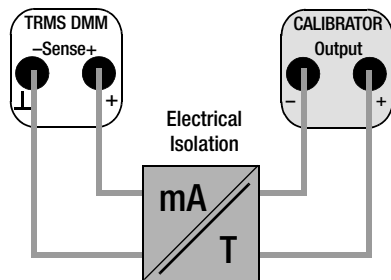

17 Measuring and Simulation in Percentages

In addition to the display of absolute measured values, measurement in percentages is also possible for the most commonly used measuring ranges (30 V DC or 30 mA DC). The desired measuring range is defined by means of lower and upper range limits to this end.

Read-out as a percentage is possible as well.

Measuring in Percentages (current and voltage measurement)

- Set the measuring function and the measuring range to 30 V DC or 30 mA DC with the rotary switch and the MANIAUTO key.
- Press the ESCIFUNC and MANIAUTO keys simultaneously.
- Select a value for 0% (lower range limit) with the Δ ∇ keys and acknowledge with the ON/OFF key.

- Select a value for 100% (upper range limit) with the Δ ∇ keys and acknowledge with the ON/OFF key.
- The measuring range now includes a span of 0 to 100%, and the unit of measure (V or mA) is displayed along with a percentage value.
- Exit the “percentage measuring” function by pressing the ESCIFUNC key, or by turning the rotary switch.

Simulation in Percentages (current source only except in dual mode)

- Select the simulation function and the output range (Isink/Isource = 4 ... 20 mA) with the rotary switch and the MANIAUTO key.
- Press the ESCIFUNC and MANIAUTO keys simultaneously.
- Select a value for 0% (lower range limit) with the Δ ∇ keys and acknowledge with the ON/OFF key.
- Select a value for 100% (upper range limit) with the Δ ∇ keys and acknowledge with the ON/OFF key.
- The output range now includes a span of 0 to 100%, and the unit of measure (V or mA) is displayed along with a percentage value.
- Exit the “percentage simulation” function by pressing the ESCIFUNC key, or by turning the rotary switch.

Measuring and Simulation in Percentages in the Dual Mode

The following combinations are possible for the measuring functions (U and I) and all simulation functions:

- Absolute measurement – simulation in percentages
- Measurement in percentages – absolute simulation
- Measurement in percentages – simulation in percentages

Measuring and output ranges for measuring and simulation in percentages are selected as described above.

The measuring function must be configured before the simulation function.

18 Interval Functions, Ramp Functions and Procedures

Two types of setpoint sequences can be generated in order to simulate sensor conditions at the inputs of transducers, transmitters and buffer amplifiers:

Interval sequences (see chap. 18.1)

Ramp sequences (see chap. 18.2)

With the help of METRAWin®90-2 software as an accessory, procedures with up to 99 steps can be generated at the PC in addition to the above mentioned sequences.

The following parameters must be specified to this end: measuring function, measuring range, tolerance limits, absolute limit values, setpoints and expected values. Up to 10 procedures can be uploaded to the calibrator. The procedures are then selected by name and started on-site. Measured values saved to the procedures can be subsequently read out with a PC.

18.1 Interval Sequences – INT Function

Output ranges are divided into rising or falling interval steps with this function, and the number of interval steps, as well as their duration, can be specified. Above all, this function is suited for the calibration of analog indicators and recorders during single-handed operation.

Input parameters for interval sequences include:

- All simulator functions except for Hz can be adjusted as output quantities.
- A lower (*StArt*) and an upper (*End*) range limit can be selected for each output quantity from within the overall range.
- The number of steps can be set within a range of 1 ... 99.9. The number of steps can be entered as a whole number as well, which is especially practical for analog indicators and recorders with non-standardized scale divisions.
- The interval duration per step (*t1*) can be selected from within a range of 1 second to 60 minutes.
- The sequences can be run manually or automatically.
- Step jumps can be selected manually (*RuTo* = no) with the Δ ∇ keys, or automatically (*RuT* = yes) with selectable time per step.

Examples of Interval Sequences:

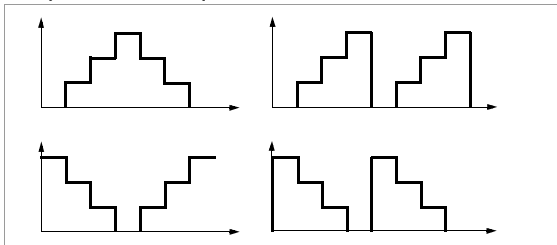

Manual Interval Sequence

After configuring all parameters in accordance with the menu flowchart on page 23 for manual interval sequence read-out (*Int*, *RuTo* = no), the individual steps can be triggered with the Δ ∇ keys.

The relationship between the output signal and each of the key operations is depicted with the help of the following example.

Example of a Manually Controlled Interval Sequence

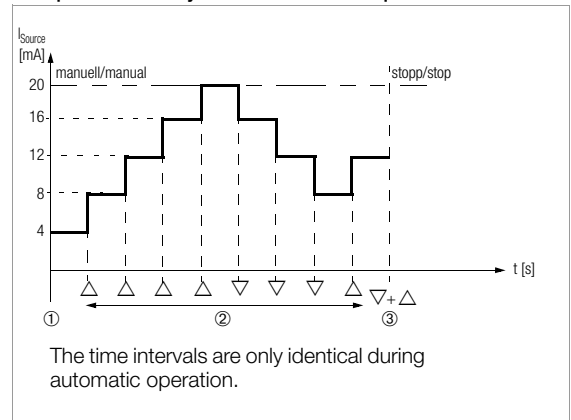

Key

- 1 The sequence is started by pressing the Δ key when *Int StArt* is displayed (see Menu Flowchart on page 22).
- 2 The sequence is stopped by pressing the Δ or the ∇ key, and is started again in the corresponding direction when the same key is pressed once again.
- 3 Stop the interval sequence by simultaneously pressing and holding the Δ and the ∇ key (2 audible acoustic signals must be generated).

Automatic Interval Sequence

Automatic execution of a programmed sequence range is above all advisable if feeding to a signal circuit, and scanning of the peripheral device under test are physically separated. After configuring all parameters in accordance with the menu flowchart on page 23 for the “automatic interval sequence” (*Int, Auto = YES*), the sequence can be started, and stopped or continued at any desired time.

Example of an Automatic Interval Sequence

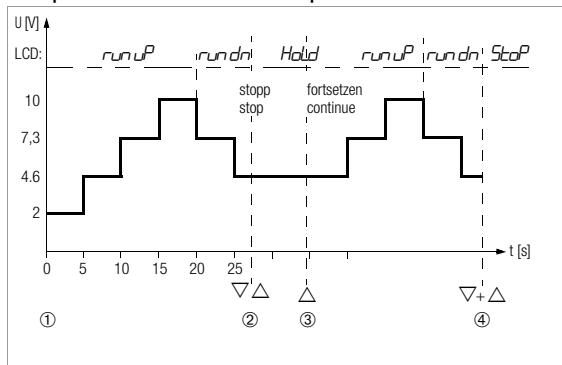

Interval parameters: Output quantity: U (0 ... 15 V range), *Start* = 2 V, *End* = 10 V, number of interval steps = 3, $t_1 = 5$ s, auto = Yes (yes for automatic sequence)

Key:

- 1 The sequence is started by pressing the \downarrow key when *Int Start* is displayed (see Menu Flowchart on page 22).
- 2 The sequence is stopped by pressing the Δ or the ∇ key. Interval time elapsed thus far is saved as t_x .
- 3 The sequence is resumed by pressing the Δ key, and remaining sequence duration t_y is equal to $t_1 - t_x$.
- 4 Stop the interval sequence by simultaneously pressing and holding the Δ and the ∇ key (2 audible acoustic signals must be generated).

Menu Flowchart: Starting and Stopping the Interval Sequence

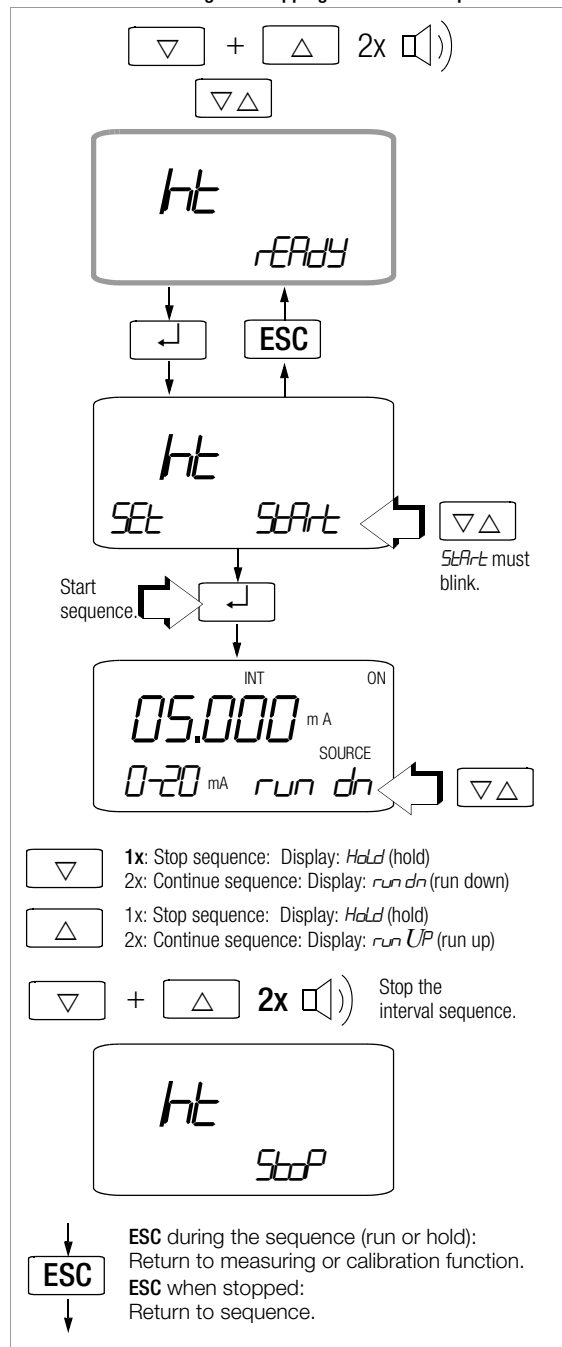

Menu Flowchart: Interval Parameters Configuration

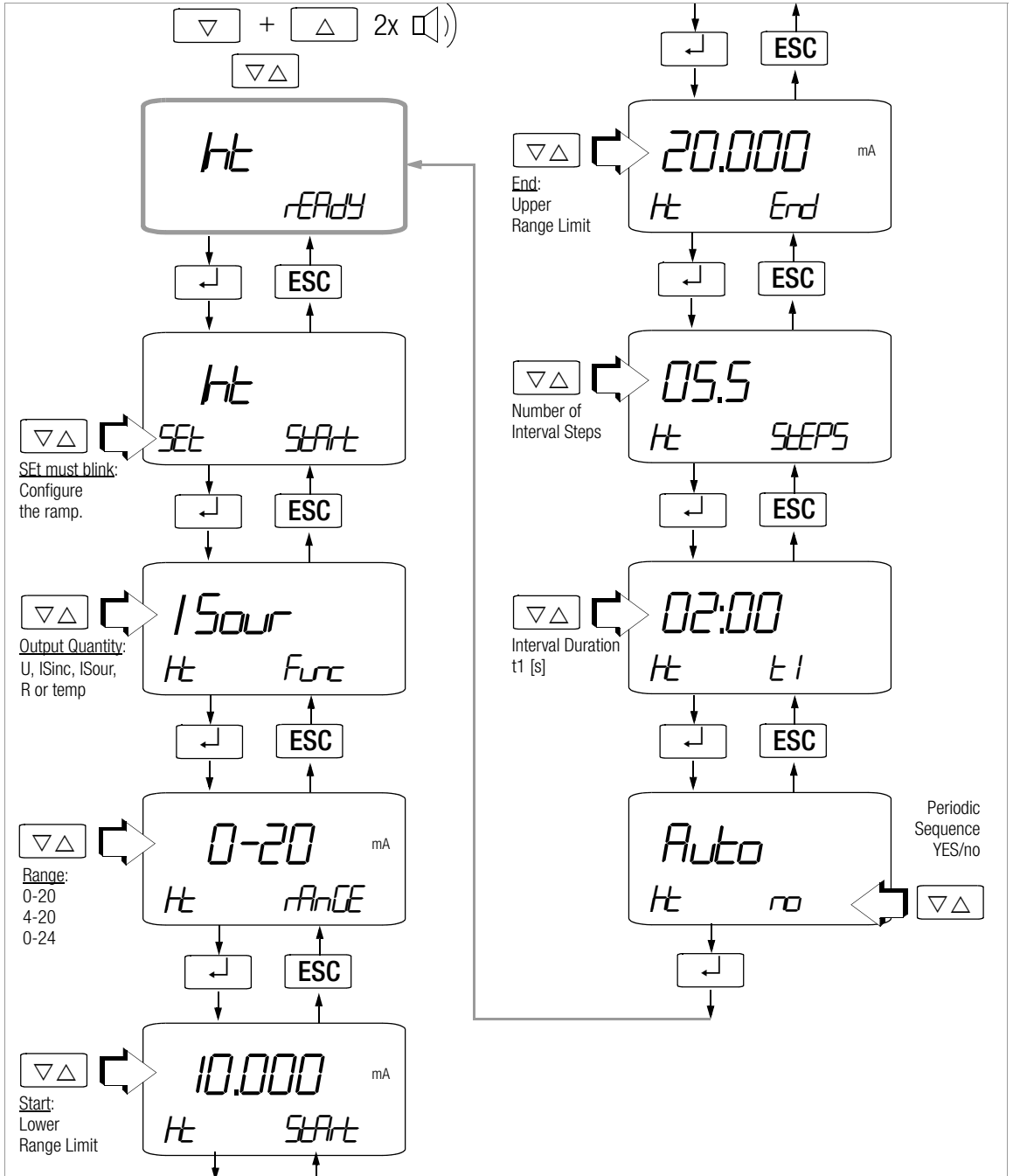

18.2 Read-Out a Periodic Ramp – RAMP Function

Ramp-type signals can be used to test dynamic performance of devices under test, or entire measuring circuits. An example would be control loop performance with a setpoint specified via the analog setpoint input at the controller. The instrument can be used to replace costly hardware and software for the set-up of long-term test bays with cyclical time sequences.

Parameters for the ramps depicted below include:

- The following functions can be adjusted as output quantities: voltage U, current sink I Sink, current source I Source, resistance R or temperature temp.
- A lower (*Start*) and an upper (*End*) range limit can be selected for each output quantity. For standard signals these are always 0 ... 10 V and 0/4 ... 20 mA, and are otherwise values from within the entire range.
- Rise time t_1 and decay time t_3 are adjustable from 0 seconds ... 60 minutes.
- Dwell time t_2 at the upper and lower range limits is adjustable from 0 seconds ... 60 minutes.
- There are 2 ramp sequences:
 - Once only: t_1, t_2, t_3
 - Repetitive: $t_1, t_2, t_3, t_2, t_1, t_2, t_3, \dots$

Examples of Ramp Sequences:

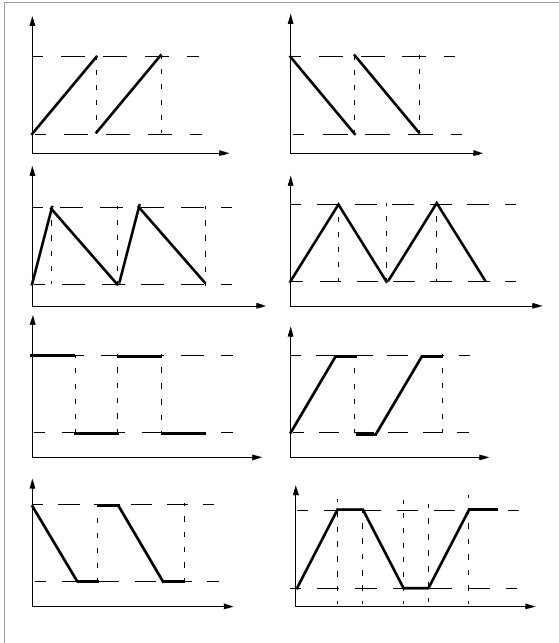

Example of a Periodic Ramp Sequence

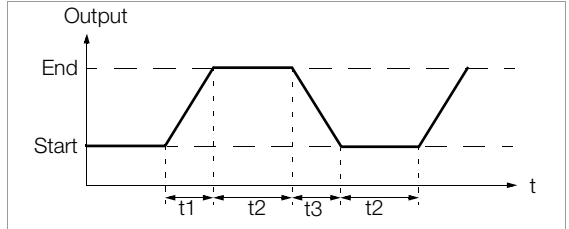

Manually Controlled Ramp Sequences

After configuring all parameters in accordance with the menu flowchart on page 25, rising or decaying ramps can be triggered with the Δ and the ∇ keys.

The relationship between the output signal and each of the key operations is depicted with the help of the following example.

Example of a Manually Controlled Ramp Sequence

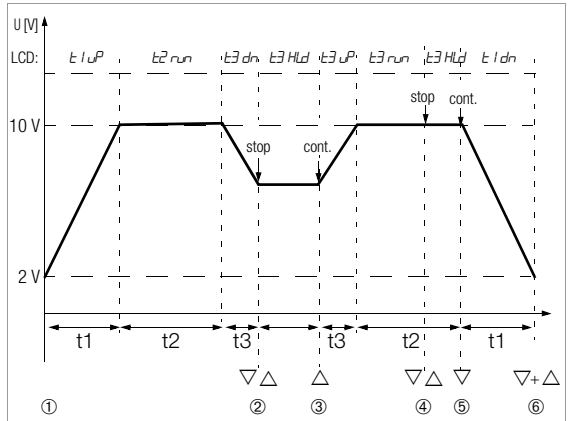

Ramp parameters: Output quantity: U (0 ... 15 V range), *Start* = 2 V, *End* = 10 V, $t_1 = 5$ s, $t_2 = 8$ s, $t_3 = 5$ s, repeat = Yes (yes for periodic ramp)

Key

- The sequence is started by pressing the \downarrow key when *RAMP Start* is displayed (see Menu Flowchart on page 26).
- Stop the decaying ramp within decay time t_3 with the Δ or the ∇ key.
- Start a rising ramp within remaining decay time t_3 with the Δ key.
- Stop the ramp sequence with the Δ or the ∇ key.
- Start a decaying ramp with the ∇ key, remaining dwell time t_2 is deleted.
- Stop the ramp sequence by simultaneously pressing and holding the Δ and the ∇ keys (2 audible acoustic signals must be generated).

Menu Flowchart: Ramp Parameters Configuration

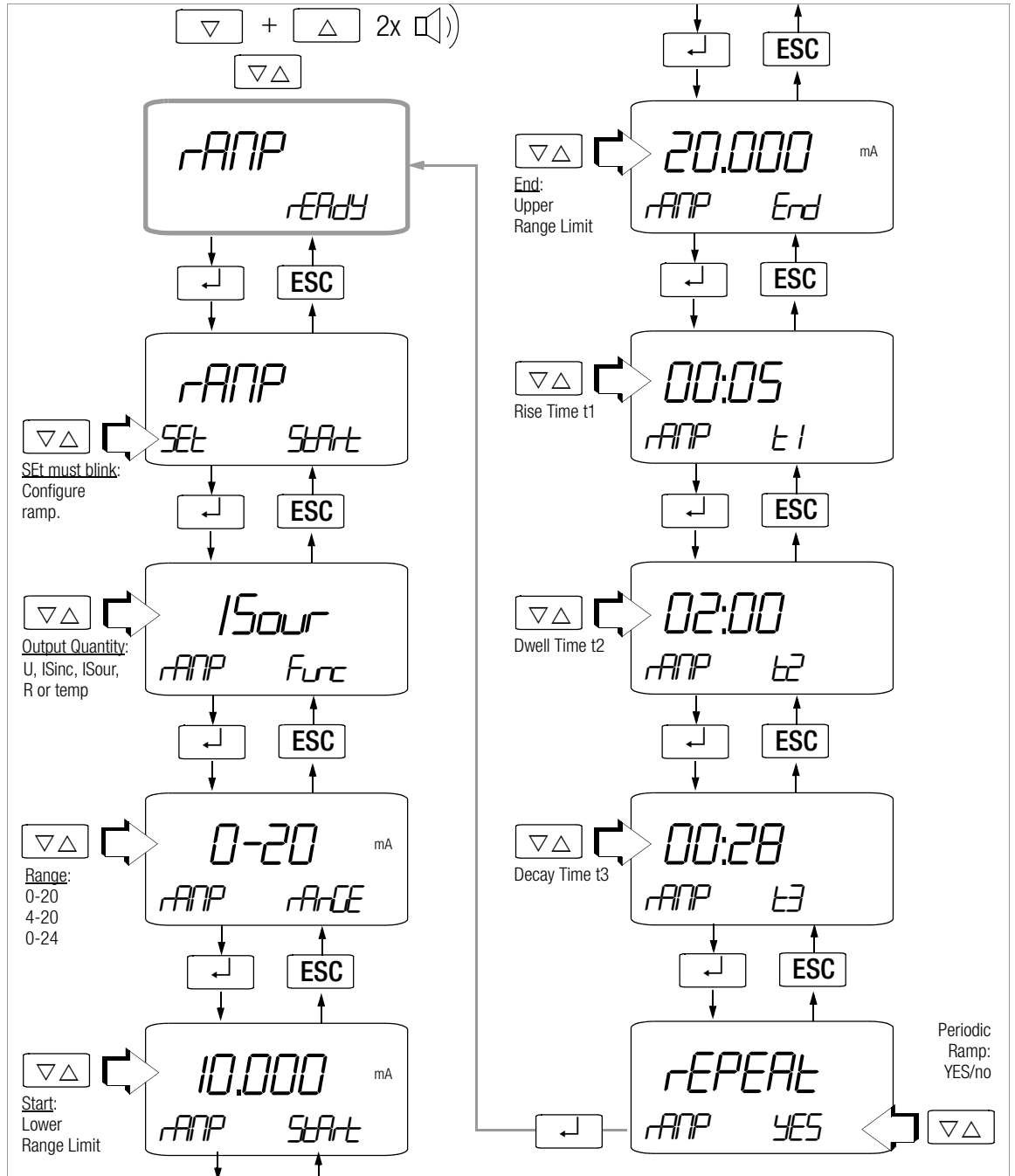

Menu Flowchart: Starting and Stopping the Ramp Sequence

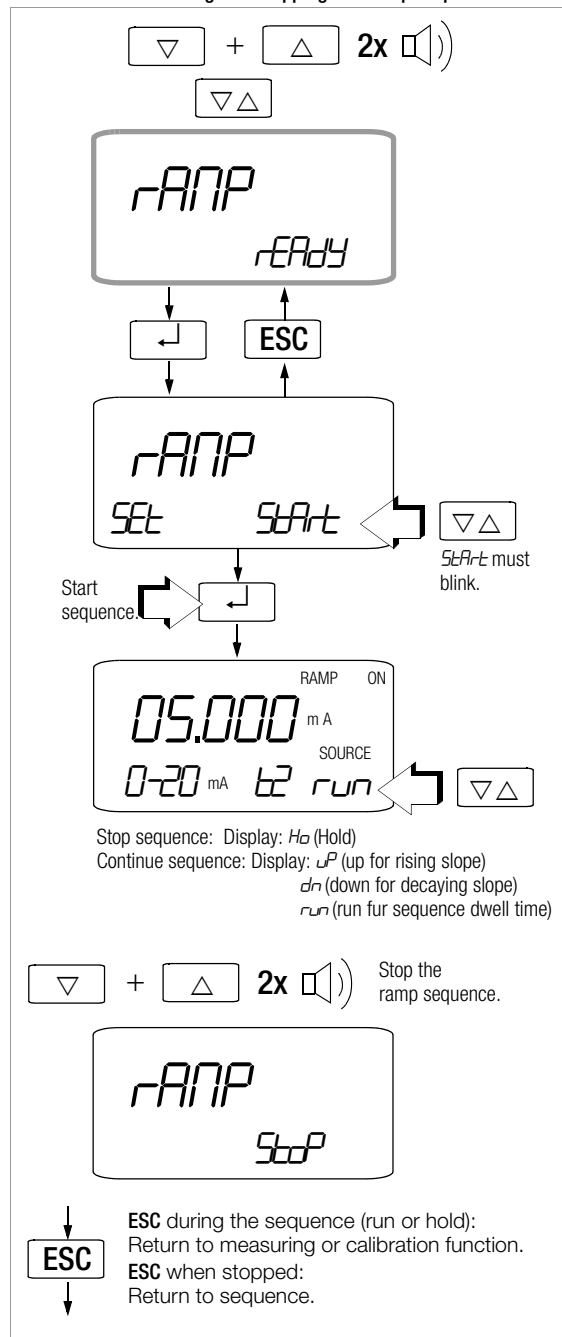

19 Using the Menus – from the Initial InFO Menu to Operating and Measuring Parameters

Menu-driven operation via the initial *rFo* menu allows the user to query online help, activate the memory and query memory occupancy, activate the interface and configure device parameters.

- ⇨ The initial *rFo* menu is accessed by simultaneously pressing and holding the ESC/FUNC and ON/OFF keys with the instrument switched on until “*rFo*” appears at the display.
- ⇨ The display can be switched from the main “*rFo*” menu to the other main menus including “*StAr-E*”, “*rANP*”, “*SEnd*” and “*SEt*”, and back to the “*rFo*” menu by repeatedly pressing the $\nabla \Delta$ keys.
- ⇨ After accessing the desired main menu, the associated sub-menus are opened by activating the \downarrow key.
- ⇨ The desired parameter is selected by repeatedly pressing the $\nabla \Delta$ keys.
- ⇨ Acknowledge with the \downarrow key in order to change the corresponding parameter or parameters.
- ⇨ After the desired digit has been selected with the $\leftarrow \rightarrow$ keys and the value has been adjusted with the $\nabla \Delta$ keys, the next digit is accessed with the \downarrow key, or the display is returned to the start menu or switched to the next sub-menu.
- ⇨ The measuring mode is started by repeatedly pressing the ESC/FUNC key until the measuring display appears.
- ⇨ The multimeter is switched off by pressing and holding the ON/OFF key until the display goes blank.

The following pages include an overview of the menu structure.

Main Menus and Sub-Menus

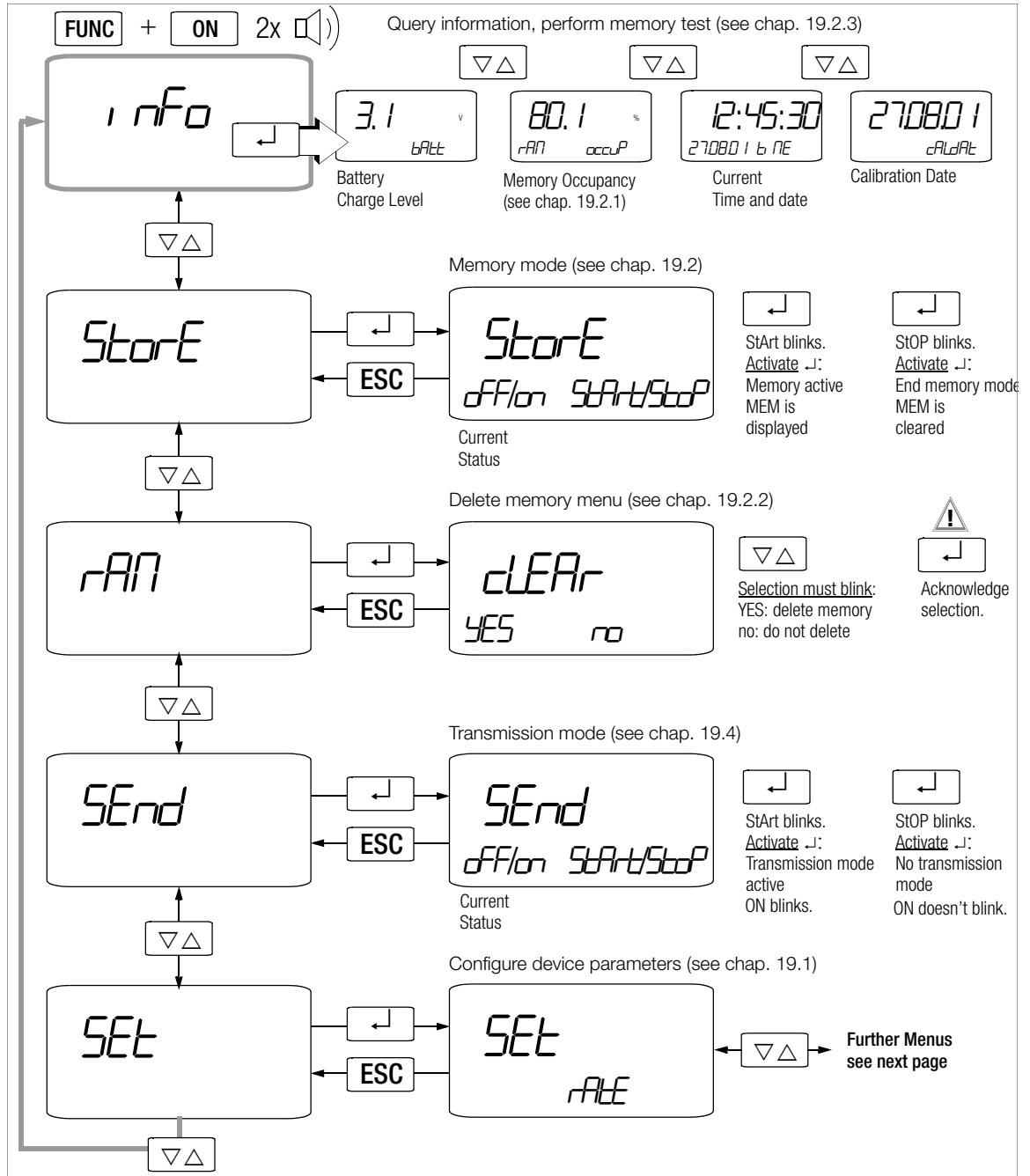

Continuation of page 27 (bottom)

Set sampling rate (see also chap. 19.1)

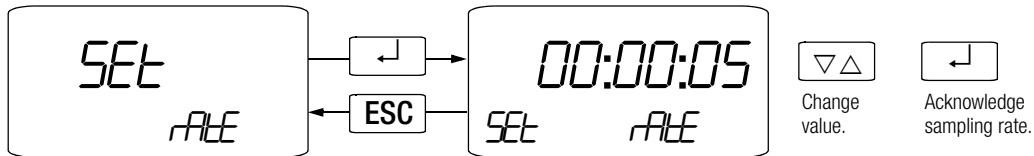

Possible settings:
 (mm:ss:zh, m=minutes, s=seconds, z=tenths of seconds, h=hundredths of seconds)
 0.50, 00:00:01, 00:00:02, 00:00:05, 00:00:10, 00:00:20, 00:01:00
 00:02:00, 00:05:00, 00:10:00, 00:20:00, 01:00:00, SAMPL

Set device address

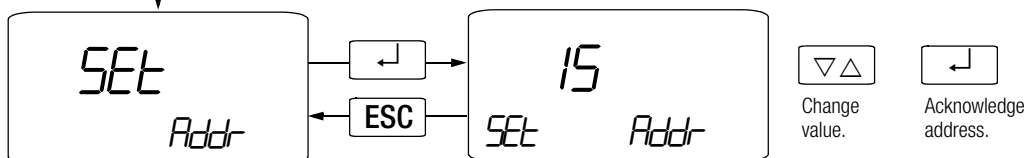

Possible settings (see also chap. 19.4): 0 ... 15

Set time

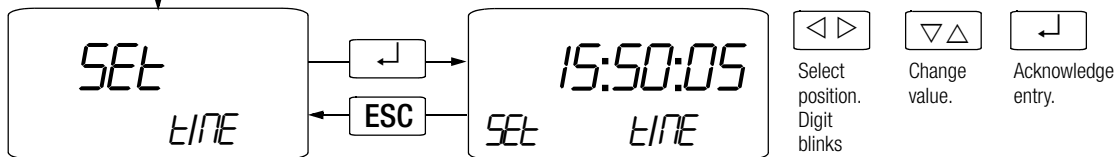

Possible settings (hh:mm:ss, hh=hour, mm=minutes, ss=seconds)

Set date

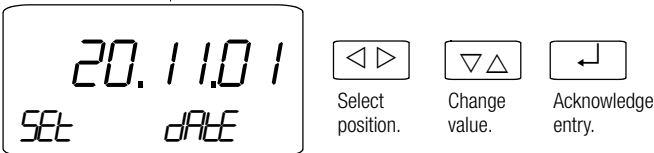

Possible settings (TT:MM:JJ, TT=day, MM=month, JJ=year)

19.1 Sampling *rAtE*

The sampling rate specifies the time interval after which the respective measured value is transmitted to the interface or to measured value memory.

Certain sampling rate limit values apply to various measured quantities, and these may not be exceeded (see table below).

Measured Quantity	Sampling Rate
V $\overline{\text{---}}$, A $\overline{\text{---}}$,	0.5 s
V \sim , A \sim , \rightarrow \rightarrow \rightarrow \rightarrow)	0.5 s
Ω , Ω \rightarrow \rightarrow), °C (Pt100, Pt1000)	0.5 s
Hz	1 s
°C (J, K)	2 s
F	0.5 ... 5 s

SAMPLE

If the sampling rate ("*rAtE*" menu) is set to "*SAMPL*" (event), one measured value is saved each time the ESC|FUNC and Δ TA|X Δ LEAP keys are simultaneously pressed, after the memory mode has been activated.

The contents of the memory can only be queried with the help of METRAwin[®]90-2 software.

19.2 Saving Measured Values to Memory

The instrument is equipped with a measured value memory (128 kB) which is synchronized with a quartz movement, and has an average capacity of 3,000 measured values. Minimum capacity is 2,000 measured values and maximum capacity is 4,000 values.

Data are stored to intermediate memory, or are uploaded to a PC. The system acquires measured values relative to real-time.

Measured values are stored in so-called blocks. Measured values resulting from the same measuring function are saved to the same block.

Only absolute values and absolute time stamps can be saved, i.e. not relative or Δ values, and no relative time stamps.

Memory content can only be read out with the help of a PC, an IR adapter (BD232) and METRAwin[®]10 or METRAwin[®]90-2 analysis software.

Preparing for Memory Mode Operation

- First select the desired measuring function and an appropriate measuring range.
- Check the battery charge level before starting long-term measurement recordings (see chapter 22.1 on page 38). Connect the power pack if applicable.



Note!

First set the sampling rate, and then start memory mode operation. The sampling rate cannot be changed during memory or transmission mode operation.

Starting Memory Mode Operation

- Open the "*rFd*" menu (see chapter 19 on page 26).
- Select the *StoE* menu with the ∇ Δ keys.
- *StoE* blinks after acknowledging with \downarrow .
- After acknowledging once again with \downarrow , a menu appears which allows for the entry of a file name with up to 6 alphanumeric characters. Select the desired characters with the ∇ Δ keys. The cursor is moved to the next place to the right with the \downarrow key.
- After acknowledging the sixth character with the \downarrow key, the file name is saved, memory mode operation is started and MEM appears at the display.
- Switch the display to the measuring function by pressing the ESC|FUNC key.

The SAMPLE Mode

If the sampling rate is set to "*SAMPL*" (see chapter 19.1), individual measured values can be saved manually within the selected measuring function by simultaneously pressing the ESC|FUNC and DATA|CLEAR keys



Note!

The selection of another measuring function with the rotary switch or the ESC|FUNC key does not effect memory mode operation.

If the sampling rate is 20 s or longer, the display is deactivated to prolong battery service life.

Ending Memory Mode Operation

- Open the "*rFd*" menu (see chapter 19 on page 26).
- Select the *StoE* menu with the ∇ Δ keys.
- *StoE* blinks after acknowledging with \downarrow .
- Press the \downarrow key. Memory mode operation is ended. MEM is cleared from the display.
- The display is returned to the measuring function by pressing the ESC|FUNC key.
- The memory mode can also be exited by switching the instrument off.

19.2.1 rAM OCCUP – Querying Memory Occupancy

Memory occupancy can be queried from the “*rF0*” menu. The main display shows current occupancy as a percentage between 001% and 100%.

19.2.2 rAM_{CLEAR} – Clearing the Memory



Attention!

This function deletes all measured values from memory.

19.2.3 tEST_{RAM} – RAM Test Function



Attention!

This function deletes all measured values from memory. Do not perform the RAM test during memory mode operation.

No other functions can be activated during the RAM test – the following message is displayed: “*bu55*”. The test has a duration of 1 minute. Two test samples are written to memory, and are subsequently read out. “*Good*” appears at the display if the test is completed successfully.

Significance of possible messages:

<i>bu55</i>	RAM test in progress
<i>Good</i>	RAM test passed
<i>Error</i>	RAM test failed

If the error message appears, a hardware problem may be the cause. Send the instrument to our Repair and Replacement Parts department in such cases (see chapter 24).

19.3 Activating the Default Values

Previously entered changes can be undone, and the default settings can be reactivated. This may be advisable under the following circumstances:

- After the occurrence of software or hardware errors
- If you are under the impression that the calibrator does not work correctly
- ⇨ Simultaneously press and hold the ESC/FUNC, MAN/AUTO and DATA/CLEAR keys, and switch the instrument on with the ON/OFF key.

19.4 Transmission Mode Operation with RS 232 Interface

The calibrator is equipped with a bidirectional infrared interface for the transmission of measurement and calibration data to a PC. The data are optically transferred through the instrument housing by means of infrared light to an interface adapter (accessory), which is attached to the instrument. The adapter's RS 232 interface allows for the establishment of a connection to the PC via an interface cable.

Beyond this, commands and parameters can be transmitted from the PC to the instrument as well. The following functions can be executed:

- Configuration and read-out of measuring and calibration parameters
- Measuring function and measuring range selection
- Start measurements/calibration
- Read out measured values
- Programming of user-specific procedures

Activating the Interface

The interface is switched on manually as described below for transmission mode operation. The instrument continuously transmits measurement data to the PC via the interface adapter in this operating mode.

The interface is activated automatically by the PC for receiving operation (i.e. instrument receives data from the PC).

Starting Transmission with Menu Functions

INFO ▾ SEnd ↵ StArt ↵

The  symbol blinks at the display in order to indicate interface operation.

Automatic Activation and Deactivation of Transmission Mode Operation

If the sampling rate is 20 s or longer, the display is switched off automatically between samples in order to prolong battery service life.

Exception: continuous operation

As soon as an event occurs, the display is automatically switched back on.

Configuring Interface Parameters

Addr – Address

If several instruments are connected to the PC via interface adapters, a unique address must be assigned to each device. Address 1 should be used for the first device address, 2 for the second etc. If only one multimeter is used, an address between 1 and 14 should be selected. Address 15 is not used for addressing, i.e. the device with address 15 always responds, regardless of the actual address.

20 Accessories

BD232 interface adapters (without memory) allow for remote control of the instrument, as well as transmission of measurement data to the PC in combination with calibration software METRAwin[®]90-2 and/or the measurement data logging software METRAwin[®]10.

USB-Hit interface adapters

Alternatively, the METRA HIT | 28C can be connected to a USB port at the PC via a USB-Hit adapter. A virtual COM port is assigned to the adapter by its driver software.

A 2x series multimeter which can be optionally embedded in a calibration system can be connected via another USB-Hit adapter with a second USB interface at the PC.

METRAwin[®]10 Software

METRAwin[®]10 software is used to process and display measurement data at a PC. Sampling can be triggered manually with an adjustable sampling interval, or in a signal-dependent fashion. Storage of data in ASCII format can be controlled with two trigger thresholds per measuring channel, as well as by means of system time.

Software METRAwin[®]90-2

This software allows for paperless documentation and management of calibration results, the creation of calibration procedures and remote control of the calibrator. METRA HIT | 28C sequence controls can be implemented online, or off-line after downloading complete calibration procedures.

The following conditions must be fulfilled in order to allow for use of METRAwin[®]10 or METRAwin[®]90-2 :

Hardware Requirements

- IBM compatible WINDOWS PC, Pentium-CPU with at least 64 MB RAM
 - SVGA monitor with a minimum of 800 x 600 pixels
 - Hard disk with at least 40 MB available memory
 - 3½" floppy disk drive for 1.4 MB floppies or CD-ROM drive
 - MICROSOFT compatible mouse
 - If print-outs are required: a WINDOWS supported printer
 - 1 free serial COM interface for utilizing BD232
- or
- 1 USB interface for utilizing USB-Hit

Operating System Software Requirements

- ☞ WINDOWS 95, 98, ME, NT4.0, 2000 or XP

METRA | VIEW PC Analysis Software

METRA | VIEW PC software is a multilingual, measurement data logging program for recording, visualizing, evaluating and documenting measured values from METRA HIT | 28C (also METRA HIT | 27 or METRAHIT | X-TRA)

The following conditions must be fulfilled in order to allow for use of METRA | VIEW :

Hardware Requirements

- IBM compatible Windows PC, Pentium processor with 200 MHz or better and at least 64 MB RAM
- SVGA monitor with at least 1024 x 768 pixels
- Hard disk with at least 40 MB available memory
- CD-ROM drive
- Microsoft compatible mouse
- Windows-supported printer
- 1 USB port for using USB-Hit

Operating System Software Requirements

- MS Windows 98, ME, 2000 or XP

21 Characteristic Values

21.1 Calibrator

Calibration Function	Simulator Range	Resolution 30000 Digits (4 $\frac{3}{4}$ places)	With Load of	Intrinsic Error	Over-load
Direct Voltage Simulator				\pm (% of s. + mV)	I_{max}
V	0... \pm 300 mV	0.01 mV	700 Ω	0.05 + 0.02	18 mA ²⁾
	0 ... 3 V	0.1 mV	1000 Ω	0.05 + 0.2	
	0 ... 10 V	1 mV	1000 Ω	0.05 + 2	
	0 ... 15 V	1 mV	1000 Ω	0.05 + 2	
Pulse / Frequency Generator Keying ratio (mark-to-space ratio): 50%, amplitude: 10 mV ... 15 V				\pm (% of s. + Hz)	I_{max}
Hz	1 Hz ... 1 kHz	0,1 ... 8Hz ¹⁾	1000 Ω	0,05 + 0,2	18 mA
Current Source				\pm (% of s. + μ A)	
mA	4 ... 20 mA	1 μ A	700 Ω	0.05 + 2	
	0 ... 20 mA				
	0 ... 24 mA				
Current Sink				\pm (% of s. + μ A)	
mA	4 ... 20 mA	1 μ A	$V_{in} = 4 \dots 27$ V	0.05 + 2	27 V
	0 ... 20 mA				
	0 ... 24 mA				
Resistance-Type Sensor Ω_2 & Ω_4				\pm (% of s. + Ω)	I_{max}
Ω	5...2000 Ω_2	0.1 Ω	0.05...0.1...5...6	0.05 + 0.2	5 mA
	0...2000 Ω_4				

¹⁾ Frequencies of over 29 Hz can only be selected at limited intervals.

²⁾ Shut off when $I_{max} > 30$ mA



Note!

Observe maximum allowable voltage for connection from external sources to the calibrator output in the event of a current sink: $U_{ext} 0 \dots 27$ V. In the event of operating errors, such as the short-term application of a high operating voltage or an interference voltage up to the maximum rated voltage of 250 V, the instrument is protected by a replaceable fuse F3 in the calibrator section, this means that the F3 fuse may be tripped in the event of an overload $> I_{max}/U_{max}$. As a result of an operating error during 4-wire measurement (Ω_4) F1, F2 and F3 may be tripped.

Simulator for Temperature Sensors (Resolution: 0.1 K)

Sensor Type	Simulator Range in $^{\circ}$ C	Simulator Range in $^{\circ}$ F	Intrinsic Error	Over-load
Resistance Thermometer per IEC 751			\pm (% of s.+K)	I_{max}
Pt100	-200...+850	-328...+1562	0.1 + 0.5	5 mA
Pt1000	-200 ...+300	-328 ...+572	0.1 + 0.2	
Resistance Thermometer per DIN 43760			\pm (% of s.+K)	I_{max}
Ni100	-60...+180	-76...+356	0.1 + 0.5	5 mA
Ni1000	-60...+180	-76 ...+356	0.1 + 0.2	
RTD Sensor Current: 0.05 ... 0.1...4 ... 5 mA			*	
Thermocouples per DIN and IEC 584-1			\pm (% of s.+K) **	I_{max}
K (NiCr/Ni)	-250...+1372	-418...+2501	0.1 + 1	18 mA
J (Fe/CuNi)	-210...+1200	-346...+2192		
T (Cu/CuNi)	-270...+400	-454...+ 752		
B (Pt30Rh/Pt6Rh)	+500...+1820	+932...+3308		
E (NiCr/CuNi)	-270...+1000	-454...+1832		
R (Pt13Rh/Pt)	-50...+1768	-58...+3214		
N (NiCrSi/NiSi)	-270...+1300	-454...+2372		
S (Pt10Rh/Pt)	-50...+1768	-58...+3214		
J (Fe/CuNi)	-200...+900	-328...+1652		
U (Cu/CuNi)	-200...+600	-328...+1112		

* Without internal reference junction

** Relative to fixed reference temperature in $^{\circ}$ C and thermovoltage of the thermocouple

Reference junction, internal: 2 K intrinsic error

Reference junction, external: entry of -30 ... 40 $^{\circ}$ C

Key

rdg. = reading (measured value)

s. = setting

d = digit

Thermocouple Simulation Error in [°C]

Thermocouple error is specified in the technical data as thermovoltage error: ΔU . ΔT error is dependent upon characteristic thermocouple slope.

In consideration of characteristic thermocouple non-linearity, which also applies to slope (1^{st} dT/dU derivation), mathematically calculated ΔT error is shown in the following table for all thermocouple types in the 100 °C sub-range. The values shown in the table represent maximum possible error for the respective sub-range.

All specified error values are increased by 2 °K if an **internal** reference temperature is used.

If an **external** reference temperature other than 0 °C is used, the table values are adjusted by the amount of the reference temperature.

Example

Ref. temp. external = 50 °C

Sub-range 100 ... 200 °C becomes 150 ... 250 °C

For display in °F: numeric values in °F are increased by a factor of 1.8.

The °F sub-ranges are calculated as follows:

$$^{\circ}\text{F} = 32 + ^{\circ}\text{C} \times 1.8$$

Additional Error for Thermocouple Simulation

Thermocouple Type	T Error in °C for Thermocouple Types at Ref. Temp. 0°C										
	J	L	T	U	K	E	S	R	B	N	
- 200 ... -100	1.17	0.83	1.52	1.2	1.59	1.03					2.38
- 100 ... 0	0.55	0.56	0.78	0.77	0.73	0.51	≥-50° 4.79	≥-50° 5.29			1.03
0 ... 100	0.42	0.41	0.52	0.51	0.53	0.35	3.77	3.92			0.77
100 ... 200	0.46	0.45	0.47	0.49	0.6	0.36	2.78	2.75			0.73
200 ... 300	0.51	0.51	0.47	0.46	0.63	0.39	2.47	2.36			0.7
300 ... 400	0.56	0.56	0.49	0.49	0.67	0.43	2.31	2.19			0.71
400 ... 500	0.6	0.6		0.51	0.71	0.48	2.28	2.09			0.74
500 ... 600	0.63	0.62			0.76	0.53	2.24	2.06	4.12		0.78
600 ... 700	0.64	0.63			0.82	0.58	2.23	2.02	3.54		0.82
700 ... 800	0.66	0.64			0.89	0.64	2.21	1.99	3.12		0.87
800 ... 900	0.73	0.66			0.96	0.71	2.18	1.95	2.84		0.93
900 ... 1000	0.83				1.04	0.77	2.16	1.93	2.62		0.99
1000 ... 1100	0.9				1.12		2.16	1.91	2.46		1.05
1100 ... 1200	0.96				1.22		2.17	1.92	2.34		1.13
1200 ... 1300					1.32		2.2	1.94	2.27		1.21
1300 ... 1400					≤ 1370 °C; 1.39		2.24	1.99	2.22		
1400 ... 1500							2.31	2.04	2.19		
1500 ... 1600							2.39	2.12	2.2		
1600 ... 1700							2.52	2.23	2.24		
1700 ... 1800							≤ 1760 °C; 2.76	≤ 1760 °C; 2.42	2.33		

21.2 Multimeter

Measuring Function	Measuring Range	Resolution at Upper Range Limit		Input Impedance		Intrinsic Error at Max. Resolution under Reference Conditions		Overload Capacity ³⁾	
						$\pm(\dots\% \text{ rdg.} + \dots \text{ d})$	$\pm(\dots\% \text{ rdg.} + \dots \text{ d})$		
		300000 ¹⁾	30000 ¹⁾	DC	AC _{TRMS} ⁶⁾	DC	AC _{TRMS} ⁶⁾	Value	Duration
V	300 mV	1 μ V	10 μ V	> 20 M Ω	11 M Ω // < 50 pF	0.05 + 15	0.5 + 30 (>500d)	250 V DC AC eff Sinus	cont.
	3 V	10 μ V	100 μ V	11 M Ω	11 M Ω // < 50 pF	0.05 + 15	0.2 + 30 (>100d)		
	30 V	100 μ V	1 mV	10 M Ω	10 M Ω // < 50 pF	0.05 + 15	0.2 + 30 (>100d)		
	300 V	1 mV	10 mV	10 M Ω	10 M Ω // < 50 pF	0.05 + 15	0.2 + 30 (>100d)		
	600 V	10 mV	100 mV	10 M Ω	10 M Ω // < 50 pF	0.05 + 15	0.2 + 30 (>100d)	600 V CAT I	
Voltage drop at approx. upper range limit									
mA	3 mA	10 nA	100 nA	DC	AC _{TRMS} ⁶⁾	DC	AC _{TRMS} ⁶⁾	0.36 A F1/F2	cont.
	30 mA	100 nA	1 μ A	160 mV	160 mV	0.05 + 15	0.5 + 30 (>100d)		
	300 mA	1 μ A	10 μ A	200 mV	200 mV	0.05 + 15	0.5 + 30 (>100d)		
				Open-circuit voltage	Meas. current at upper range limit	$\pm(\dots\% \text{ rdg.} + \dots \text{ d})$			
Ω_4	30 m Ω		0.01m Ω	0.6 V	100 mA	0.5 + 5		± 0.6 V F3	cont.
	300 m Ω		0.1 m Ω	0.6 V	100 mA	0.5 + 5			
	3 Ω		1 m Ω	0.6 V	10 mA	0.5 + 5			
	30 Ω		1 m Ω	0.6 V	10 mA	0.5 + 5			
Ω_2	300 Ω	1 m Ω		0.6 V	250 μ A	0.07 + 20 ⁴⁾		250 V DC AC eff sine	5 min.
	3 k Ω	10 m Ω		0.6 V	45 μ A	0.07 + 15 ⁴⁾			
	30 k Ω	100 m Ω		0.6 V	4.5 μ A	0.07 + 15			
	300 k Ω	1 Ω		0.6 V	1.5 μ A	0.07 + 15			
	3 M Ω	10 Ω		0.6 V	150 nA	0.07 + 15			
Ω_{d}	300 Ω		0.1 Ω	3 V	1 mA	0.5 + 5			
\rightarrow	3 V		0.1 mV	6 V	1 mA	0.5 + 5		22 V	cont.
Zener \rightarrow	15 V		1 mV	22 V	1 mA	1 + 5 (> 10 d)		F3	
				Discharge resistance	U_0 max	$\pm(\dots\% \text{ rdg.} + \dots \text{ d})$			
F	3 nF		1 pF	10 M Ω	3 V	1 + 5 ⁴⁾		250 V DC AC eff sine	5 min.
	30 nF		10 pF	10 M Ω	3 V	1 + 5 ⁴⁾			
	300 nF		100 pF	1 M Ω	3 V	1 + 5			
	3 μ F		1 nF	100 k Ω	3 V	1 + 5			
	30 μ F		10 nF	11 k Ω	3 V	1 + 5			
				f_{min} ²⁾		$\pm(\dots\% \text{ rdg.} + \dots \text{ d})$			
Hz	300 Hz		0.01 Hz	1 Hz		0.05 + 5 ⁵⁾		250 V	cont.
	3 kHz		0.1 Hz					250 V	
	100 kHz < 30 kHz > 30 kHz		10 Hz					100 V 30 V	

1) Display: 5% places for DC and 4% places for AC, a different resolution and sampling rate can be selected in the rAtE menu for saving and transmitting measured values.

2) Lowest measurable frequency for sinusoidal measuring signals symmetrical to the zero point

3) at 0 ° ... + 40 °C

4) ZERO is displayed for "zero balancing" function.

5) Range 300 mV~: $U_E = 100 \text{ mV}_{\text{eff/rms}} \dots 300 \text{ mV}_{\text{eff/rms}}$
 3 V~: $U_E = 0.3 \text{ V}_{\text{eff/rms}} \dots 3 \text{ V}_{\text{eff/rms}}$
 30 V~: $U_E = 3 \text{ V}_{\text{eff/rms}} \dots 30 \text{ V}_{\text{eff/rms}}$
 300 V~: $U_E = 30 \text{ V}_{\text{eff/rms}} \dots 300 \text{ V}_{\text{eff/rms}}$

For voltages > 100 V: Power limiting of $3 \cdot 10^6 \text{ V} \cdot \text{Hz}$
 6) 20 ... 45 ... 65 Hz ... 1 kHz Sinus, for influences see page 35.

Key

rdg. = reading (measured value)

d = digit

F1, F2, F3 = fuses, see chap. 22.3

Measuring Function	Standard	Temperature Sensor	Measuring Range	Resolution	Intrinsic Error for Max. Resolution under Reference Conditions $\pm(\dots\% \text{ rdg.} + \dots \text{ d})^1$	Overload Capacity ²⁾			
						Value	Duration		
°C/°F	RTD	DIN IEC 751 EN 60751 (ITS90)	Pt 100	-200.0 ... -100.0 °C	0,1 K	1 K	250 V DC eff sine	5 min	
				-100.0 ... +100.0 °C		0.8 K			
				+100.0 ... +850.0 °C		0.5 + 3			
			Pt 1000	-200.0 ... +100.0 °C		0.8 K			
				+100.0 ... +850.0 °C		0.5 + 3			
				DIN 43760		Ni 100			-60.0 ... +180.0 °C
	Ni 1000	-60.0 ... +180.0 °C	0.5 + 3						
	TC	DIN IEC 584-1 EN 60584	K (NiCr-Ni) J (Fe-CuNi) T (Cu-CuNi) E (NiCr-CuNi) B (Pt30Rh-Pt6Rh) R (Pt13Rh-Pt) S (Pt10Rh-Pt) N (NiCrSi-NiSi) L (Fe-CuNi) U (Cu-CuNi)	-250.0... +1372.0 °C	0.8 + 5				
				-210.0... +1200.0 °C	0.8 + 5				
				-270.0... +400.0 °C	0.8 + 5				
				-270.0... +1000.0 °C	0.8 + 5				
				+100.0... +500.0 °C	1 + 5 K				
				+500.0... +1820.0 °C	1 + 2 K				
				-50.0... +1768.0 °C	1 + 2 K				
				-50.0... +1768.0 °C	1 + 2 K				
				-270.0... +1300.0 °C	0.8 + 5				
				-200.0... +900.0 °C	0.8 + 5				
				-200.0... +600.0 °C	0.8 + 5				
				DIN 43710	L (Fe-CuNi)	-200.0... +900.0 °C			0.8 + 5
				U (Cu-CuNi)	-200.0... +600.0 °C	0.8 + 5			

- 1) Plus sensor deviation
2) at 0 ° ... + 40 °C

RTD Resistance temperature detectors: The temperature value is determined on the basis of the value specified in the standard

TC Thermocouples: The temperature value is determined on the basis of the value specified in the standard with deactivated internal reference junction; additional error with internal reference junction: ± 2 K.

Influencing Quantities and Influence Error

Influencing Quantity	Sphere of Influence	Measured Quantity / Measuring Range ¹⁾	Influence Error $\pm(\dots\% \text{ rdg.} + \text{d})/10$ K	
Temperature	0 ... +21 °C and +25 ... +40 °C	V DC, °C (TC)	0.1 + 10	
		V AC	0.5 + 10	
		3/30 mA DC	0.1 + 10	
		3/30 mA AC	0.5 + 10	
		300 mA DC, AC	0.5 + 10	
		300Ω/3/30/300 kΩ 2L	0.2 + 10	
		3 MΩ 2L	0.5 + 10	
		30 MΩ 2L	1 + 10	
		Ω 4L	1 + 10	
		3/30/300 nF/3/30 μF	0.5 + 10	
		Hz	0.1 + 10	
		°C (RTD)	0.2 + 10	
		Source quantity¹⁾		
		mV/V, °C (TC)	0.1 + 10	
	Ω, °C (RTD)	0.2 + 10		
	mA source	0.1 + 10		
mA sink	0.1 + 10			

Influencing Quantity	Frequency	Measured Quantity / Measuring Range	Influence Error ²⁾ $\pm(\dots\% \text{ rdg.} + \text{d})$
Frequency V_{AC}	> 20 Hz ... 45 Hz	300.00 mV ...	2 + 30
	> 65 Hz ... 1 kHz	250.0 V	

Influencing Quantity	Frequency	Measured Quantity / Measuring Range	Influence Error $\pm(\dots\% \text{ rdg.} + \dots \text{ d})$
Frequency I_{AC}	> 20 Hz ... 45 Hz	3 mA 30 mA 300 mA	1 + 30
	> 65 Hz ... 1 kHz		

- 1) With zero balancing
2) Specified error valid as of display values of 10% of the measuring range

Influencing Quantity	Sphere of Influence	Measured Quantity / Measuring Range ¹⁾	Influence Error ²⁾
Measured Quantity Waveshape	Crest Factor CF	1 ... 2	±1 % rdg.
		2 ... 4	±5 % rdg.
		4 ... 5	±7 % rdg.
	Allowable crest factor CF of the periodic quantity to be measured is dependent upon the displayed value:		
	<p>Current and Voltage Measurement</p>		

Influencing Quantity	Sphere of Influence	Measured Quantity / Measuring Range ¹⁾	Influence Error
Relative Humidity	75 % 3 days instrument off	V, A, Ω F, Hz °C	1 x intrinsic error

Influencing Quantity	Sphere of Influence	Measuring Range	Damping ±dB
Common Mode Interference Voltage	Interference quantity max. 250 V AC 50 Hz, 60 Hz sine	V DC	> 90 dB
		300 mV ... 30 V AC	> 80 dB
		300 V AC	> 70 dB
Series Mode Interference Voltage	Interference quantity: V AC, respective nominal value of the measuring range, max. 250 V AC, 50 Hz, 60 Hz sine	V DC	> 60 dB
		Interference quantity max. 250 V DC	V AC > 60 dB

Real-Time Clock

Accuracy	±1 minute per month
Temperature Influence	50 ppm/K

Reference Conditions

Ambient Temperature	+23 °C ±2 K
Relative Humidity	40 ... 60%
Measured Quantity Frequency	45 ... 65 Hz
Measured Quantity Waveshape	sine, deviation between RMS and rectified value < 0.1%
Battery Voltage	4.5 V ±0.1 V

Response Time (multimeter functions)

Response Time (after manual range selection)

Measured Quantity / Measuring Range	Response Time for Digital Display	Measured Quantity Jump Function
V DC, V AC A DC, A AC	1.5 s	from 0 to 80% of upper range limit value
300 Ω ... 3 MΩ	2 s	from ∞ to 50% of upper range limit value
30 MΩ	5 s	
Continuity	< 50 ms	
→	1.5 s	from 0 to 50% of upper range limit value
°C Pt100	max. 3 s	
3 nF ... 30 μF	max. 2 s	
>10 Hz	max. 1.5 s	

Display

LCD panel (65 mm x 30 mm) with display of up to 3 measured values, unit of measure, type of current and various special functions.

Display / Char. Height 7-segment characters
Main display: 12 mm
Auxiliary displays: 7 mm

Places 5¾ places ≅ 309999 steps
Overflow Display "OL" appears
Polarity Display "—" sign is displayed if plus pole is connected to "⊥"

LCD Test All display segments available during operation of the 28C are activated after the instrument is switched on.

Data Interface

Data Transmission optical via infrared light through the housing

with interface adapter as accessory

Type RS 232C, serial, per DIN 19241

Bidirectional baud rate (read and write)

(MM ↔ PC)

SI232-II: all adjustable baud rates
BD232, USB-Hit: 9600 baud

Power Supply

Batteries 3 ea. 1.5 V mignon cell alkaline manganese per IEC LR6 or equivalent rechargeable batteries. If rechargeable batteries are used, they must be charged externally.

Service Life With alkaline manganese (2200 mAh)

Measuring Function	Current	Service Life
V, Hz, mA, Ω_2 , F, °C	25 mA	70 h
Standby (MEM + clock)	350 μ A	approx. 1 year
Calibration Function		Service Life
mV, thermocouple	48 mA	40 h
15 V	85 mA	20 h
Ω , RTD	95 mA	18 h
Sink, 20 mA	175 mA	10 h
Source, 20 mA	140 mA	12 h

If voltage drops below 2.7 V, the instrument is switched off automatically.

Battery Test “-L-” is displayed automatically if battery voltage drops to below approx. 3.5 V.

Mains Power When mains power pack NA5/600 is connected, the power supply comes from the mains power pack; battery power is not consumed; there is no risk of batteries being charged.

Fuses (Location of fuses, see chap. 22.3)
DMM F1/F2 (mA measuring ranges):
 F500mA/250V, 5 mm x 20 mm
 1.5 kA switching capacity at 250 V AC and ohmic load
Calibrator F3:
 M125mA/250V, 5 mm x 20 mm
 1.5 kA switching capacity at 250 V AC and ohmic load

Multimeter Electrical Safety

Safety Class II per IEC/EN 61010-1:2001
 /VDE 0411-1:2002

Measurement Category II

Operating Voltage 250 V

Fouling Factor 2

Test Voltage 2.2 kV~ per IEC/EN 61010-1:2001
 /VDE 0411-1:2002

Electromagnetic Compatibility (EMC)

Interference emission EN 61326: 2002 class B
 EN 61326: 2002

Interference immunity IEC 61000-4-2: 1995/A1: 1998
 Feature A:
 8 kV atmospheric discharge
 4 kV contact discharge
 IEC 61000-4-3: 1995/A1: 1998
 Feature B:
 3 V/m

Ambient Conditions

Accuracy Range 0 °C ... +40 °C

Operating Temperature -10 °C ... +50 °C

Storage Temperature -25 °C ... +70 °C
 (without batteries)

Relative Humidity 40% ... 75%,
 no condensation allowed
 to 2000 m

Elevation indoors,
 Deployment outdoors: only in the specified ambient conditions

Mechanical Design

Protection Housing: IP 50

Extract from table on the significance of IP codes

IP XY (1 st digit X)	Protection against the penetration of solid foreign matter	IP XY (2 nd digit Y)	Protection against the penetration of water
0	no protection	0	no protection
1	≥ 50.0 mm \varnothing	1	vertical dripping
2	≥ 12.5 mm \varnothing	2	dripping (15° gradient)
3	≥ 2.5 mm \varnothing	3	spray-water
4	≥ 1.0 mm \varnothing	4	splashwater
5	protection from dust	5	hoseproof

Dimensions 84 mm x 195 mm x 35 mm

Weight approx. 420 gr. with batteries

22 Maintenance



Attention!

Disconnect the instrument from the measuring circuit before opening to replace batteries or fuses!

22.1 Battery



Note!

Removing the Battery During Periods of Non-Use

The integrated quartz movement for the calibrator draws power from the battery, even when the instrument is switched off. It is advisable to remove the battery during long periods of non-use for this reason (e.g. vacation). This prevents excessive depletion of the battery, which may result in damage under unfavorable conditions.

The current battery charge level can be queried in the "Info" menu: ESC|FUNC + 0n ▽ △ inFo ↵ X.X V (bAtt).

Make sure that no battery leakage has occurred before initial start-up, and after long periods of storage. Continue to inspect the batteries for leakage at short, regular intervals.

If battery leakage has occurred, carefully and completely clean the electrolyte from the instrument with a damp cloth, and replace the batteries before using the instrument.

If the "⊥" symbol appears at the display, the batteries should be replaced as soon as possible. You can continue working with the instrument, but reduced measuring accuracy may result.

The instrument requires three 1.5 V batteries in accordance with IEC R 6 or IEC LR 6, or equivalent rechargeable batteries.

Replacing the Batteries

- ⇨ Set the instrument face down onto a flat working surface, loosen the two screws at the back and lift off the housing base, starting at the bottom. The housing top and housing bottom are held together with the help of snap hooks at the top front.
- ⇨ Remove the batteries from the battery compartment.
- ⇨ Insert three 1.5 V mignon cells into the battery compartment, making sure that the plus and minus poles match up with the provided polarity symbols.

- ⇨ Important for reassembly: First set the housing base onto the housing top and align accurately (see photo below). Then press the two housing halves together, first at the bottom front (a), and then at the top front (b).



- ⇨ Secure the housing base with the two screws.
- ⇨ Please dispose of depleted batteries in accordance with environmental protection regulations!

22.2 5 V Power Pack

Use only the NA5/600 power pack from GMC-I Gossen-Metrawatt GmbH in combination with your instrument. This assures operator safety by means of an extremely well insulated cable, and safe electrical isolation (nominal secondary ratings: 5 V/600 mA). Installed batteries are disconnected electronically if the power pack is used, and need not be removed from the instrument.

Country	Type / Article Number
Germany	Z218F

22.3 Fuses

If the fuses F1 and F2 for the mA measuring ranges blow, the voltage measuring function remains active. If a fuse should blow, eliminate the cause of overload before placing the instrument back into service!

If the fuse F3 for the simulator blows, the multimeter continues to function normally.

Replacing the Fuses

- Open the instrument as described under Replacing the Batteries.
- Remove the blown fuse with the help of an object such as a test probe, and replace it with a new fuse.



Attention!

Use specified fuses only!
If fuses with other blowing characteristics, other current ratings or other breaking capacities are used, the operator is placed in danger, and protective diodes, resistors and other components may be damaged.
The use of repaired fuses or short-circuiting the battery holder is prohibited.

Location of fuses

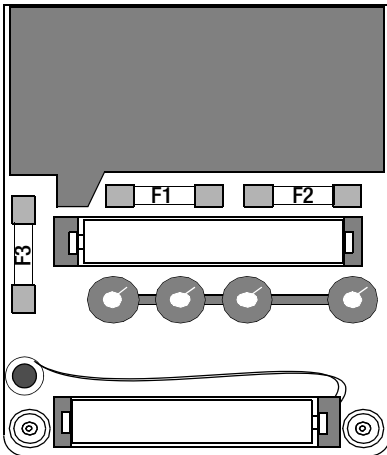

22.4 Housing

No special maintenance is required for the housing. Keep outside surfaces clean. Use a slightly dampened cloth for cleaning. Avoid the use of cleansers, abrasives and solvents.

Collection of Used Instruments and Environmentally Compatible Disposal

The calibrator is a category 9 product (monitoring and control instrument) in accordance with ElektroG (*German Electrical and Electronic Device Law*). This device is not subject to the RoHS Directive.

We identify our electrical and electronic devices (as of August 2005) in accordance with WEEE 2002/96/EG and ElektroG with the symbol shown to the right per DIN EN 50419. These devices may not be disposed with the trash. Please contact our service department regarding the return of old devices (see chapter 24).



23 Calibrator / Multimeter Messages

The following messages appear at the main or the auxiliary displays as required. See "Symbols used in the Digital Display" on page 2 for messages displayed via fixed display segments.

Message	Function	Significance
<i>buSY</i>	Memory test	See chapter 19.2.3
<i>CRmndt</i>	Memory or transmission mode	Following functions cannot be executed: set time/date, clear ram, ram test
<i>Error</i>	Memory test	See chapter 19.2.3
<i>oL</i>	Measuring	Indicates overflow
<i>Good</i>	Memory test	See chapter 19.2.3
<i>Hi Curr</i>	Calibrator mode simulate Voltage/Pulse	High current = current too high ($I > 18 \text{ mA}$)
	Calibrator mode simulate Resistance/RTD	High current = current too high ($I > 4,5 \text{ mA}$)
<i>LoCurr</i>	Calibrator mode Resistance simulation	Low current = current too low ($I < 40 \mu\text{A}$) Indicates that connector jacks are open, e.g. with Pt and Ni sensors
<i>OutOL</i>	Calibrator mode Voltage simulator Pulse and frequency generator	Out of limit = limit value violated ($I > 30 \text{ mA}$), 3 acoustic signals are generated at the same time and the simulator jacks are deactivated. After eliminating the cause of the overload, the output can be reactivated with the ON/OFF key.
<i>LoVOLT</i>	Calibrator mode Current Sink	$U < 3 \text{ V}$ (insufficient loop impedance)
<i>Hi burd</i>	Calibrator mode Current source	High burd = high burden, the resistance applied by the connected circuit is too high. The resulting voltage at the calibrator exceeds or is equal to 20 V

Blinking Unit of Measure

All measuring and calibration functions are balanced in accordance with technical specifications at the factory for each series METRA HIT | 28C calibrator. If a unit of measure blinks, this indicates that the balancing constant which has been established and saved to the calibrator or the multimeter is no longer available for the respective function. If this is the case, measurement results may deviate from the specification. We recommend sending the instrument to our Repair and Replacement Parts department for rebalancing (see chapter 24).

24 Repair and Replacement Parts Service DKD Calibration Lab * and Rental Instrument Service

When you need service, please contact:

GMC-I Gossen-Metrawatt GmbH
Service Center
Thomas-Mann-Strasse 20
90471 Nürnberg • Germany
Phone +49-(0)-911-8602-0
Fax +49-(0)-911-8602-253
E-Mail service@gossenmetrawatt.com

This address is only valid in Germany.
Please contact our representatives or subsidiaries for service
in other countries.

* **DKD** Calibration Laboratory for Electrical Quantities DKD–K–19701 accredited per DIN EN ISO/IEC 17025

Accredited measured quantities: direct voltage, direct current values, DC resistance, alternating voltage, alternating current values, AC active power, AC apparent power, DC power, capacitance and frequency

Competent Partner

GMC-I Gossen-Metrawatt GmbH is certified in accordance with DIN EN ISO 9001:2000.

Our DKD calibration laboratory is accredited by the Physikalisch Technische Bundesanstalt (*German Federal Institute of Physics and Metrology*) and the Deutscher Kalibrierdienst (*German Calibration Service*) in accordance with DIN EN ISO/IEC 17025 by under registration number DKD–K–19701.

We offer a complete range of expertise in the field of metrology: from **test reports** and **proprietary calibration certificates** right on up to **DKD calibration certificates**.

Our spectrum of offerings is rounded out with free **test equipment management**.

An on-site **DKD calibration station** is an integral part of our service department. If errors are discovered during calibration, our specialized personnel are capable of completing repairs using original replacement parts.

As a full service calibration laboratory, we can calibrate instruments from other manufacturers as well.

DKD Calibration Certificate Reprints

If you order a DKD calibration certificate reprint for your instrument, please provide us with the reference numbers indicated in the upper and lower most fields of the calibration seal. We do not need the instrument's serial number.

25 Warranty

The warranty period for all measuring and calibration instruments of the METRA HIT series is 3 years from delivery. A warranty period of 12 months is granted for calibration. Warranty covers defective material and workmanship, not including any damage caused by inappropriate use or operating errors as well as any follow-up costs.

26 Product Support

When you need support, please contact:

GMC-I Gossen-Metrawatt GmbH
Product Support Hotline
Phone +49-(0)-911-8602-112
Fax +49-(0)-911-8602-709
E-Mail support@gossenmetrawatt.com

Edited in Germany • Subject to change without notice • A pdf version is available on the internet

GMC-I  **GOSSEN METRAWATT**

GMC-I Gossen-Metrawatt GmbH
Thomas-Mann-Str. 16-20
90471 Nürnberg • Germany

Phone +49-(0)-911-8602-0
Fax +49-(0)-911-8602-669
E-Mail info@gossenmetrawatt.com
www.gossenmetrawatt.com