

METRA HIT 16U

Cable Multimeter for Measurements in Symmetrical Copper Cable Networks

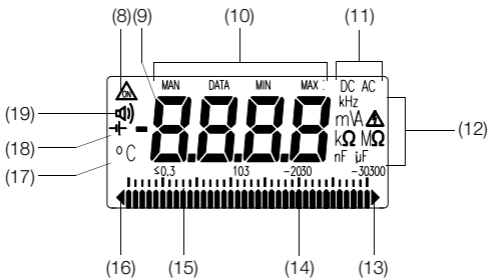

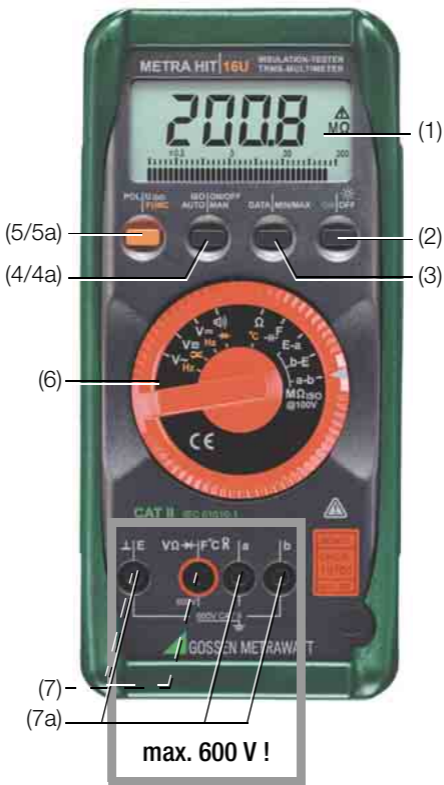

Key to Measuring Instrument Layout

- (1) LCD panel
- (2) **ON/OFF**: Key for switching the device, as well as display illumination, on and off in the specified order:
 - Press briefly: device on
 - Press briefly: LCD illumination on
 - Press briefly: LCD illumination off
 - Press and hold: device off
- (3) **DATA/MIN/MAX**: key for following saving measured values and Min-Max values
- (4) **AUTO/MAN**
 - Press briefly: manual range selection
 - Press and hold: automatic range selection
- (4a) **ISO ON/OFF**: insulation resistance measurement:
 - Press briefly: switch insulation measurement on and off (rotary selector switch must be set to $M\Omega_{ISO}$)
- (5) **FUNC**: Multifunctional key
 - Press briefly: change to measurement sub-function, e.g. Hz, ∞ , \rightarrow , °C (red symbols)
 - Press and hold: current function or return to main measuring function (white symbols)
- (5a) **POL/ISO**: insulation resistance measurement:
 - Press and hold key to reverse polarity of conductors under test (rotary selector switch must be set to $M\Omega_{ISO}$)
- (6) **Rotary selector switch** for measuring function selection
- (7) Connector jacks for multimeter measurement
- (7a) Connector jacks for insulation resistance measurement

Key to LCD Panel Layout

- (8) Symbol for continuous duty
- (9) Digital display with decimal point and polarity display
- (10) Display for manual measuring range selection, and for storage of measured and MIN/MAX values
- (11) DC/AC indicator
- (12) Unit of measure
- (13) Indicates overranging
- (14) Pointer for analog display
- (15) Scale for analog display
- (16) Indicates that the negative analog display range has been exceeded
- (17) Unit of measure °C for temperature measurement (prerequisite: accessory temperature sensor)
- (18) Low battery display
- (19) Indicates that acoustic signals are active

Table of Contents	Page
1	Safety Features and Precautions 5
2	Initial Start-Up 7
3	Selecting Measuring Functions and Ranges 8
3.1	Automatic Measuring Range Selection 8
3.2	Manual Measuring Range Selection 8
3.3	Quick Measurements 9
4	LCD 9
4.1	Digital Display 9
4.2	Analog Display 9
4.3	Background Illumination 9
5	Measured Value Memory – DATA Function. 10
6	Saving Minimum and Maximum Values – Min-Max Function. 11
7	Voltage Measurements – V Function. 12
7.1	Socket Jack Connections 12
7.2	Transient Overvoltages 13
7.3	Voltage Measurements at Above 600 V 13
8	Resistance Measurement – Ω Function. 14
9	Alternating Current Measurement with the WZ12B Clip-On Current Transformer – Clip Function ... 14
10	Continuity and Diode Testing – Diode Function and Beeper 15
11	Capacitance Measurement – F Function. 16
12	Frequency Measurement – Hz Function. 17
13	Temperature Measurement – $^{\circ}\text{C}$ Function 18
14	Insulation Resistance Measurement in Telecommunications Networks – $M\Omega_{\text{ISO}}$ Function. 20
14.1	Connecting the Measurement Cables 20
14.2	Detection of Interference Voltages 20
14.3	Performing Insulation Resistance Measurements 21
14.4	Ending Measurement and Discharge 22
15	RS 232 C Interface 23
16	Characteristic Values 24
17	Maintenance 30
17.1	Battery 30
17.2	Housing 31
18	Repair and Replacement Parts Service DKD Calibration Lab * and Rental Instrument Service 31
19	Guarantee 32
20	Product Support 32

1 Safety Features and Precautions

You have selected an instrument which provides you with a high level of safety.

This instrument fulfills the requirements of the applicable European and national EC guidelines. We confirm this with the CE marking. The relevant declaration of conformity can be obtained from GOSSEN METRAWATT GMBH.

The cable multimeter is manufactured and tested in accordance with safety regulations IEC 61010–1:2001/EN 61010–1:2001/VDE 0411–1:2002. When used for its intended purpose, safety of the operator, as well as that of the instrument, is assured. Their safety is however not guaranteed, if the instrument is used improperly or handled carelessly.

In order to maintain flawless technical safety conditions, and to assure safe use, it is imperative that you read the operating instructions thoroughly and carefully before placing your instrument into service, and that you follow all instructions contained therein.

Observe the following safety precautions:

- The instrument may only be operated by persons who are capable of recognizing contact hazards and taking the appropriate safety precautions. Contact hazards exist anywhere, where voltages of greater than 33 V (RMS) may occur.
- Avoid working alone when taking measurements which involve contact hazards. Be certain that a second person is present.
- **Maximum allowable voltage** between any of the connector jacks (7) and earth is **600 V, category II**. Overload capacity values are listed in chapter 16.
- **Nominal voltage at the system may not exceed 600 V.**
- Voltage measurement may only be performed with the selector switch set to the $V \sim$, $V \equiv$ or $V \approx$ position. **Measurement of voltages of 150 V and greater** may only be performed with the KS17-2 cable set (personal safety). Only this cable set is suitable for measuring category III / 1000 V and IV / 600 V.
- Be prepared for the occurrence of unexpected voltages at devices under test (e.g. defective devices). For example, capacitors may be dangerously charged.
- Make certain that the measurement cables are in flawless condition, e.g. no damage to insulation, no interruptions in cables or plugs etc.
- Special care is required when measurements are made in HF electrical circuits. Dangerous pulsating voltages may be present.
- Measurements under moist ambient conditions are not permitted.
- Be absolutely certain that the **measuring ranges are not overloaded beyond their allowable capacities**. Limit values can be found in the “Measuring Ranges” table in chapter 16, “Characteristic Values”.

Meanings of symbols on the instrument:



Warning concerning a source of danger (attention: observe documentation)



Earth terminal



Continuous, doubled or reinforced insulation



Life endangering for the operator if instructions identified with this symbol are not observed



Indicates EC conformity

DKD calibration certificate (red seal):



Consecutive number

German calibration service calibration laboratory

GOSSEN-METRAWATT calibration laboratory

Date of calibration (year – month)

Repair, Parts Replacement and Balancing

When the instrument is opened, voltage conducting parts may be exposed. The instrument must be disconnected from the measuring circuit before executing repairs, replacing parts or balancing. If balancing, maintenance or repair of a live open instrument is required, this may only be carried out by trained personnel who are familiar with the dangers involved.

Defects and Extraordinary Strains

If it may be assumed that the instrument can no longer be operated safely, it must be removed from service and secured against unintentional use.

Safe operation can no longer be relied upon:

- If the device demonstrates visible damage
- If the instrument no longer functions
- After long periods of storage under unfavorable conditions

2 Initial Start-Up

Battery

Your instrument is supplied with an installed 9 V flat-cell battery in accordance with IEC 6 LR 61, and is ready for operation. **Be sure to refer to chapter 17.1, “Battery”, before initial start-up, or after your device has been in storage for a lengthy period of time.**

Switching the Instrument On

⇒ Briefly press the ON/OFF key.

Power-up is acknowledged with an acoustic signal. As long as the key is held depressed, all of the segments at the liquid crystal display (LCD) are illuminated. The LCD is shown in the diagram on page 2. The instrument is ready for use as soon as the key is released.

After switching the instrument off, it cannot be switched back on again for a period of 3 seconds.

Switching LCD Illumination On and Off

⇒ Briefly press the ON/OFF key after the instrument has already been switched on.

Illumination is switched off automatically after approximately 2 minutes.

Note: Electrical discharge and high frequency interference may cause incorrect displays to appear, and may disrupt the measuring sequence. In such cases, switch the instrument off and back on again in order to reset. If the problem persists, briefly dislodge the battery from the connector contacts.

Disconnect the instrument from the measuring circuit before opening and refer to chapter 17, “Maintenance”!

Automatic Shutdown

The instrument switches itself off automatically if the measured value remains constant for a period of approximately 10 minutes (measured value fluctuation $\leq \pm 2$ digits), assuming that none of the keys or the rotary selector switch are activated during this time.

Disabling Automatic Shutdown

The instrument can be set to continuous duty. Press the multifunction key FUNC and the ON/OFF key simultaneously when switching the instrument on to this end. Continuous duty is indicated at the LCD by means of the  symbol (8).

Switching the Instrument Off

Press and hold the ON/OFF key.

3 Selecting Measuring Functions and Ranges

3.1 Automatic Measuring Range Selection

The cable multimeter is equipped with automatic measuring range selection for all ranges except the 30 mV \equiv and the 300 mV \equiv ranges. Auto-ranging is active as soon as the instrument is switched on. The instrument automatically selects the measuring range which allows for highest possible resolution of the applied quantity.

When the instrument is switched to frequency measurement, the previously selected voltage measuring range remains active.

The instrument is automatically switched to:

The next highest range at $\pm (3099 \text{ digits} + 1 \text{ digit})$
 The next lowest range at $\pm (240 / 280 \text{ digits} - 1 \text{ digit})$

3.2 Manual Measuring Range Selection

Auto-ranging can be deactivated and measuring ranges can be selected manually in accordance with the following table.

Manual operation is deactivated by pressing and holding the AUTO/MAN key (approx. 1 s), by turning the rotary selector switch or by switching the instrument off and then back on again.

If the instrument is switched back to auto-ranging in the 30 mV \equiv or the 300 mV \equiv range, the 3 V \equiv range is selected automatically.

↓ AUTO/ MAN (4)	Function	Acknowledge- ment	
		Dis- play	Acoustic Signal
brief	Manual mode active: utilized measuring range is fixed	MAN (10)	1 x
brief	Range switching sequence for: V — : 3 V → 30 V → 300 V → 600 V → 30 mV → 300 mV → 3 V.. V \sim/Hz : 3 V → 30 V → 300 V → 600 V → 3 V → ... Ω : 30 M Ω → 30 Ω → 300 Ω → 3 k Ω → 30 k Ω → 300k Ω → 3 M Ω → 30 M Ω ... F : 30 nF → 300 nF → 3 μ F → 30 nF ... Hz : 300 Hz → 3 kHz → 30 kHz → 100 kHz → 300 Hz ...	MAN (10)	1 x
long	Return to automatic range selection	—	2 x

3.3 Quick Measurements

Measurements performed using a suitable fixed measuring range are executed more quickly than those which utilize automatic range selection. Quick measurement is made possible with the following two functions:

- **Manual measuring range selection**, i.e. selection of the measuring range with best resolution (see chapter 3.2)

or

- **DATA function** (see chapter 5). In this case, the correct measuring range is selected automatically after the first measurement, and the second measurement is executed more quickly.

The selected measuring range remains active for the following series of measurements with these two functions.

4 LCD

4.1 Digital Display

The measured value with decimal and plus or minus sign appears at the digital display (9). The selected unit of measure (12) and the current type (11) are displayed as well. A minus sign appears to the left of the value during the measurement of zero-frequency quantities, if the plus pole of the measured quantity is applied to the \perp input. If the upper range limit of 3099 is exceeded (or 1999 in the \rightarrow range) "OL" is displayed.

The digital display is refreshed twice per second during V and Ω measurements.

4.2 Analog Display

The analog display, which is equipped with a simulated pointer and demonstrates the same dynamic performance as a moving-coil mechanism, is refreshed 20 times per second during V and Ω measurements. This display is especially advantageous for observing measured value fluctuation, and for balancing procedures.

The analog display with linear graduation has its own polarity indicator. The analog scale (15) has a negative range of 5 scale divisions for the measurement of zero-frequency quantities, allowing for precise observation of measured value fluctuation around zero. If the measured value exceeds the display range, the triangle at the left (16) is displayed first, and polarity at the analog display is then switched after approximately 0.7 seconds. Overranging is indicated by the triangle at the right (13) (> 3099 digits, or > 1999 in the \rightarrow range).

The analog scale utilizes logarithmic graduation in the insulation resistance measuring range ($M\Omega_{ISO}$) and the pointer is replaced with a bar graph, allowing for improved measured value observation.

4.3 Background Illumination

- ⇨ Briefly press the ON/OFF key after the instrument has already been switched on.

Illumination is switched off automatically after approximately 2 minutes.

5 Measured Value Memory – DATA Function

Measured values can be automatically “frozen” with the DATA function. This is useful, for example, when contacting the measuring points with the test probes requires your full attention. After the measured value has been applied and the corresponding “condition” from the table below has been fulfilled, the measured value is frozen at the digital display and an acoustic signal is generated. The test probes can now be removed from the measuring points, and the measured value can be read from the digital display. If the measured value is less than the value specified in the table, the instrument is reactivated for storage of the next value.

The DATA function has no effect on the analog display, at which the current measured value continues to appear. However, when the digital display is “frozen”, the decimal point is fixed as well. If automatic range selection is activated, you are thus no longer able to determine which range the analog display is using. Manual range selection is not possible as long as the DATA function is active.

DATA Function	↓ DATA MIN/MAX (3)	Condition		Response from Instrument		
		Measuring Range	Measured Value Limits (digits)	Display	Digital Meas. Value	Acoustic Signal
Activate	brief				blinks	1 x
Save		V \approx ²⁾ Ω F, Hz	> 280 < OL > 280	is displayed	is displayed	1 x
Reactivate ¹⁾		V \approx ²⁾ Ω F, Hz	< 280 OL < 280	stored measured value	blinks	
Stop	long			is cleared	is cleared	2 x

¹⁾ Reactivation results from falling short of specified measured value limits.

²⁾ Except 30 mV and 300 mV ranges

The DATA function is deactivated by pressing and holding the DATA|MIN/MAX key (approx. 1 s), by turning the rotary selector switch or by switching the instrument off and then back on again.

6 Saving Minimum and Maximum Values – Min-Max Function

Minimum and maximum measured values applied to the measuring instrument's input after the Min-Max function has been activated can be "frozen" at the display. The most important use of this function is the determination of minimum and maximum values during long-term measured value observation.

The Min-Max function has no effect on the analog display, at which the current measured value continues to appear. Connect the measured quantity to the instrument and select the appropriate measuring range before activating the Min-Max function.

Measuring ranges can only be selected manually after the Min-Max function has been activated. However, saved minimum and maximum values are cleared if the measuring range is switched.

The Min-Max function is deactivated by pressing and holding the DATA/MIN/MAX key (approx. 1 s), by turning the rotary selector switch or by switching the instrument off and then back on again.

Min-Max Function	↓ DATA MIN/ MAX (3)	Mea- suring Range	Min. and Max. Measured Val- ues	Response from Instrument		
				Digital Meas. Value	MIN MAX	Acoustic Signal
1. Activate and save	2 x short 30 mV/ 300 mV and °C : 1 x short	V \approx Ω , F, Hz, °C, °F	are saved	Current mea- sured value	MIN and MAX blink	1 x
2. Save and display	↓ brief ↓ brief	V \approx Ω , F, Hz, °C, °F	Storage contin- ues in back- ground, new min. and max. values are dis- played.	Saved min. value	MIN	1 x
				Saved max. value	MAX	1 x
3. Return to 1	↓ brief	Same as 1	Same as 1, stored values are not deleted	Same as 1	Same as 1	1 x
Stop	long		are deleted	is de- leted	is de- leted	2 x

7 Voltage Measurements – V Function

- Depending upon the voltage to be measured, set the rotary selector switch to $V \sim$, $V =$ or $V \approx$.
- Connect the measurement cables as shown. The \perp connector jack should be grounded.

Measurement of voltages of 150 V and greater may only be performed with the KS17-2 cable set. Only this cable set is suitable for measuring category II / 600 V and higher, III / 1000 V or IV / 600 V.



Note!

The 30 mV \approx and 300 mV \approx measuring ranges can only be selected manually with the AUTOIMAN key!

An intermittent acoustic signal warns the operator if the measured value exceeds the upper range limit in the 600 V range.

Zero Balancing in the 30 mV \approx Measuring Range

Zero balancing is possible in the 30 mV \approx measuring range:

- Plug the measuring cables into the instrument and connect the free ends to each other.
- After selecting the measuring range, briefly press the multifunction key FUNC.

The instrument acknowledges zero balancing with an acoustic signal, and “00.00” (+ 1 digit) appears at the LCD with blinking decimal point. The voltage displayed at the moment the key is pressed serves as a reference value (max. ± 200 digits). It is automatically subtracted from all subsequent measured values.

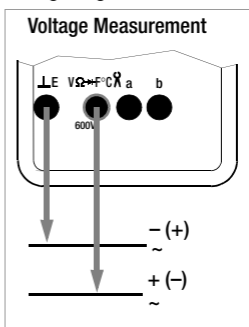

Zero balancing can be deleted:

- By pressing and holding the multifunction key FUNC, which is acknowledged with two acoustic signals
- By switching the instrument off

7.1 Socket Jack Connections



Important!

Jacks a and b may not be connected in order to prevent possible outgoing potential-transfer from the \perp / E jacks.

7.2 Transient Overvoltages

The cable multimeter's connector jacks (7) are protected against transient overvoltages of up to 4 kV with rise times of 1.2, and decay times of 50 μ s. Due to the fact that long duration overvoltages are likely to occur during measurements performed in power systems, at transformers, at motors etc., we recommend using our KS30 measuring adapter in such cases. It provides protection against transient overvoltages of up to 6 kV with rise times of 10, and decay times of 1000 μ s. It has a continuous load capacity of 1200 V_{RMS}.

Additional measuring error caused by the KS30 measuring adapter amounts to approximately -2%.

7.3 Voltage Measurements at Above 600 V

Voltages of greater than 600 V can be measured with a high-voltage probe, e.g. the HV3 or HV30 from GOSSEN METRAWATT GMBH. It is absolutely essential to ground the bonding terminal. Observe all applicable safety precautions!

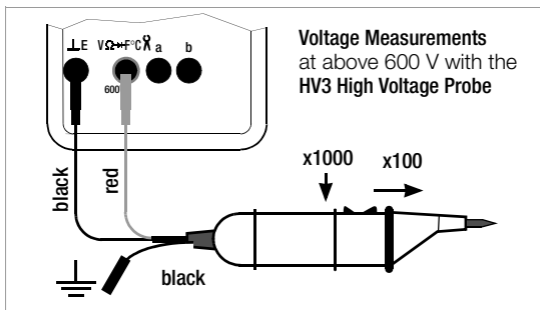

8 Resistance Measurement – Ω Function

- Make sure that the device under test is voltage-free.
Interference voltages distort measurement results!
- Set the rotary selector switch to “ Ω ”.
- Connect the device under test as shown.

Zero Balancing in the 30 Ω Measuring Range

Cable and contact resistances can be eliminated for the measurement of small resistance values in the 30 Ω range by means of zero balancing:

- Plug the measuring cables into the instrument and connect the free ends to each other.
- Briefly press the multifunction key FUNC. The instrument acknowledges zero balancing with an acoustic signal, and “00.00” (+1 digit) appears at the LCD with blinking decimal point. The resistance value measured at the moment the key is pressed serves as a reference value (max. 200 digits). It is automatically subtracted from all subsequent measured values.

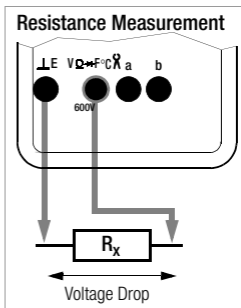

Zero balancing can be deleted:

- By pressing and holding the multifunction key FUNC, which is acknowledged with two acoustic signals
- By switching the instrument off

See chapter 14 regarding insulation resistance measurement.



Important!

If a minus sign (–) is displayed to the left of “00.00” and if the decimal point blinks, an error has occurred during zero balancing which may result in erroneous measurements.

Remedy: In order to execute a reset, briefly select another type of measurement with the rotary selector switch, or switch the instrument off and then back on again. Perform zero balancing once again.

9 Alternating Current Measurement with the WZ12B Clip-On Current Transformer – Clip Function AC

The rotary selector switch can be set to the $V \text{ AC}$ position for the performance of measurements with an interconnected WZ12B clip-on current transformer, in which case the measured value is displayed directly in amperes.

- Read the operating instructions included with the WZ12B.
- Set the rotary selector switch to $V \text{ AC}$ and briefly press the multifunction key.

⇒ Connect the measurement cables to the \perp and ∞ jacks.

WZ12B Technical Data, Abbreviated

Measuring range 10 mA ... 100 A

Frequency range 50 ... 500 Hz

Transformation ratio 1 mV / 10 mA

10 Continuity and Diode Testing – Diode Function \rightarrow and Beeper 🔊)

⇒ Make sure that the device under test is voltage-free.

Interference voltages distort measurement results!

⇒ Set the rotary selector switch to \rightarrow .

⇒ Connect the device under test as shown.

Conducting Direction and Short-Circuit

The instrument displays conducting-state voltage in volts. As long as voltage drop does not exceed the maximum display value of 1999 V, several series connected components or reference diodes can be tested with a small reference voltage.

Reverse Direction or Interruption

The measuring instrument indicates overflow: "OL".



Note!

Resistors and semiconductors which are connected in parallel to the diode distort measurement results!

Continuity and Diode Testing with Acoustic Signal

If the beeper function has been activated, the instrument generates a continuous acoustic signal for display values between 0 and 1 V, and for resistances of $< 250 \Omega$.

Beeper Function ON (default state after activation)

The beeper function is always on after the "continuity and diode testing" function has been activated with the rotary selector switch. The 🔊 symbol (18) appears at the display as well. The beeper function can be activated and deactivated by repeatedly pressing the multifunction key FUNC.

Beeper Function OFF

⇒ Briefly press the multifunction key FUNC.

Deactivation is acknowledged with an acoustic signal.

The 🔊 symbol (18) is cleared from the display. If the key is pressed and held, the beeper function is activated, which is acknowledged with two acoustic signals.

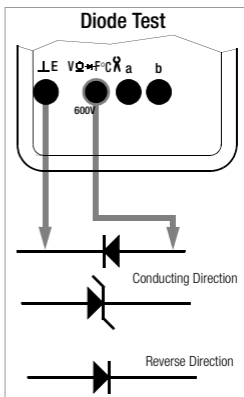

11 Capacitance Measurement – F Function

- ⇒ Make sure that the device under test is voltage-free.
Interference voltages distort measurement results!
- ⇒ Set the rotary selector switch to “F”.
- ⇒ Connect the (discharged!) device under test to the “⊥” and “F” jacks with the measurement cables.



Note!

The minus pole of polarized capacitors must be connected to the ⊥ jack.

Resistors and semiconductors which are connected in parallel to the capacitor distort measurement results!

Zero Balancing in the 30 nF Measuring Range

Measuring instrument and cable capacitances can be eliminated for the measurement of low value capacitance in the 30 nF range by means of zero balancing:

- ⇒ Connect the measurement cables to the instrument without a device under test.
- ⇒ Briefly press the multifunction key FUNC.
The instrument acknowledges zero balancing with an acoustic signal, and “00.00” (+1 digit) appears at the LCD with blinking decimal point. The capacitance value measured at the moment the key is pressed serves as a reference value (max. 200 digits). It is automatically subtracted from all subsequent measured values.

Zero balancing can be deleted:

- By pressing and holding the multifunction key FUNC, which is acknowledged with two acoustic signals
- By switching the instrument off



Important!

If a minus sign (–) is displayed to the left of “00.00” and if the decimal point blinks, an error has occurred during zero balancing which may result in erroneous measurements.

Remedy: In order to execute a reset, briefly select another type of measurement with the rotary selector switch, or switch the instrument off and then back on again.

Perform zero balancing once again.

12 Frequency Measurement – Hz Function

Frequency measurement is possible in the $V \sim$ and $V \equiv$ measuring ranges.

- ⇒ Set the rotary selector switch to $V \sim$ or $V \equiv$.
- ⇒ Apply the measured quantity as described under voltage measurement (observe footnote 4 on page 25).
- ⇒ Briefly press the multifunction key FUNC.
The instrument is switched to frequency measurement.
Frequency is displayed at the LCD.
Lowest measurable frequencies and maximum allowable voltages are included in chapter 16, “Characteristic Values”.

Switching Between Voltage and Frequency Measurement

Switching back and forth between voltage and frequency measurement is accomplished by repeatedly pressing the multifunction key FUNC:

voltage → frequency → voltage →

You can switch from frequency measurement directly back to voltage measurement:

- By pressing and holding the multifunction key FUNC, in which case switching is acknowledged with an acoustic signal. The previously selected voltage measuring range remains active.
- By turning the rotary selector switch.

13 Temperature Measurement – °C Function

Temperature can be measured in °C or °F with the help of a Pt 100 or a Pt 1000 temperature sensor.

- ⇒ Set the rotary selector switch to Ω .
- ⇒ Connect the sensor to the two jacks for multimeter measurement (7).
- ⇒ Press the multifunction key FUNC once for °C, twice for °F and three times in order to compensate for cable resistance.

The instrument is switched to temperature measurement and automatically recognizes which type of sensor has been connected (Pt 100 or Pt 1000).

The measured temperature value is displayed, and the temperature unit of measure is displayed only if °C has been selected.



Note!

Cable resistances for temperature sensors available as accessories from GOSSEN METRAWATT GMBH are compensated for automatically during temperature measurement.

Switching to temperature measurement is not possible if the 30 Ω resistance measuring range has been selected!

Compensation of Sensor Cable Resistances of up to 20 Ω

Sensor cables with resistance values up to 20 Ω which differ from those of sensors supplied by GOSSEN METRAWATT GMBH can be compensated for as follows:

- ⇒ Press the multifunction key repeatedly until the current cable resistance value is displayed.
The resistance value which will automatically be taken into consideration by the instrument after the temperature measuring range has been selected is now displayed at the LCD.
- ⇒ The resistance correction value can be set as follows:
Press the DATA/MIN/MAX key in order to increase the value, or the AUTO/IMAN key in order to reduce the value. The value is changed by one digit each time the respective key is pressed. Pressing and holding the respective key results in rapid scrolling.
- ⇒ Briefly press the multifunction key FUNC once again.
Measured temperature is displayed at the LCD. The blinking decimal point indicates that a cable resistance correction value has been entered. The correction value is retained until the instrument is switched off.
- ⇒ °C, °F and the cable resistance correction value can be displayed consecutively by repeatedly pressing multifunction key FUNC.

The temperature measurement function can be exited:

- By pressing and holding the multifunction key FUNC, which is acknowledged with two acoustic signals
- By switching the instrument off



Note!

The multimeter which will actually be utilized to perform temperature measurement must also be used to determine cable resistance. This is the only way to assure that measuring error lies within the guaranteed range.

14 Insulation Resistance Measurement in Telecommunications Networks – $M\Omega_{ISO}$ Function

Three jacks (a, b and E) are provided for **measurements in symmetrical copper cable networks** with two conductors and shield. The rotary selector switch can be set to determine whether insulation testing will be performed between E and a, b and E or a and b.

Interruption of a single core or contact with an unused core (capacitive asymmetry) can be recognized by switching rapidly with the FUNC key.

In the event of a **good cable**, the bar graph must have the same length in the a-E and b-E selector switch positions (unconnected cable only!).

Long cable: long bar graph display

Short cable: short bar graph display

The overall length of the bar graph represents a range of capacitance from 50 nF to 100 nF.

14.1 Connecting the Measurement Cables

⇨ Cable connection:

Connect the measurement cables to jacks E, a and b.

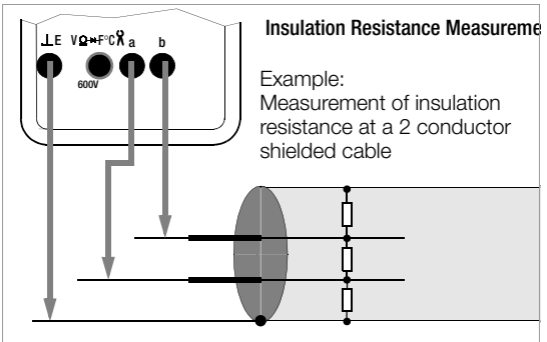

Note!

Testing the Measurement Cables

The test probes at the ends of the measurement cables should be short circuited before performing insulation resistance measurements, in order to make sure that a value close to 0 Ω is displayed at the instrument. Incorrect connection or a broken measurement cable can be detected in this way.

14.2 Detection of Interference Voltages

⇨ Turn the rotary selector switch from $M\Omega_{ISO_E-a}$, to $M\Omega_{ISO_b-E}$, and finally to $M\Omega_{ISO_a-b}$, in order to display any interference voltages for all three conductor pairs.



Note!

Insulation resistance may only be measured at voltage-free devices.

14.3 Performing Insulation Resistance Measurements



High-Voltage!

Do not touch the conductive ends of the test probes when the instrument has been activated for the measurement of insulation resistance. If at all possible, only plug in the measurement cables actually required for this test, because loose test probes and cable ends represent a contact hazard. You may otherwise be exposed to a current of 1.5 mA (limited in the measuring instrument), and although this is not life endangering, the resulting electrical shock is quite discernible. If, on the other hand, measurement is being performed on a capacitive device under test, for example a cable, it may be charged up to approximately ± 100 V. Touching the device under test after measurement has been performed is life endangering in this case!

⇒ Starting the insulation resistance measurement:

Briefly press the ISOION/OFF key.

Insulation resistance is displayed for the currently selected conductor pair.

⇒ Reversing polarity of the conductor under test:

– Normal polarity reversal:

Press and hold the POLIISO key.

– Rapid polarity reversal:

Repeatedly press and hold the POLIISO key at short intervals. bAL.C appears at the display (ballistic capacitance) for relative cable length determination.

After key activation has ceased for a period of approximately 2 seconds, the instrument is switched back to standard insulation resistance measurement.

⇒ Turn the rotary selector switch from $M\Omega_{ISO_E-a}$, to $M\Omega_{ISO_b-E}$ or to $M\Omega_{ISO_a-b}$, in order to execute the desired tests.

Auto-ranging is active during insulation resistance measurement. Manual measuring range selection is not possible.

Automatic Recognition of Interference Voltage during Insulation Resistance Measurement

If the instrument detects **interference voltage greater than 15 V AC or 25 V DC** (assuming: $U_{int} \neq U_{ISO}$, $R_{iq} < 100$ k Ω), **ERROR** is briefly displayed at the LCD. The instrument is then automatically switched to voltage measurement, and the currently measured voltage value is displayed.

**Note!**

A polarity-dependent dead zone results in erroneous measurements for automatic interference voltage detection. The dead zone has a range of 95 V to 110 V DC (physical cause: in the case of an interference voltage whose value is equal to that of measuring voltage, the two voltages neutralize one another).

Manual switching to insulation resistance measurement is disabled for as long as voltage is applied to the test terminals. When the instrument no longer detects interference voltage, or if the test probes are no longer in contact with the device under test, the instrument is automatically switched back to insulation resistance measurement. If a **voltage of greater than 110 V** is present, an intermittent acoustic signal is generated and **UHI** appears at the display. The  symbol blinks at the same time, and the device remains in the voltage measuring mode, even after interference voltage is no longer present.

**Important!**

If ERROR appears at the display, the cable (the device under test) is most likely capacitively charged to a significant extent. Remedy: Short circuit conductors a-b, a-E and b-E, and the repeat the measurement.

14.4 Ending Measurement and Discharge

⇨ Briefly press the ISOION/OFF key.

After measurement has been completed, any remaining residual voltage is displayed which may result from cable capacitance. The instrument's internal 100 kΩ resistor assures rapid discharging. However, contact to the device under test must be maintained. The falling voltage value can be observed directly at the LCD.

Do not disconnect the device under test until voltage has dropped to a value of less than 25 V!

**Note!**

The instrument's batteries are rapidly depleted during insulation resistance measurement. Deactivate the insulation resistance function between measurements for this reason. Use only alkaline manganese batteries in accordance with IEC 6 LR61.

**Note!**

Voltage measurement may only be performed with the rotary selector switch set to the $V \sim$, $V \equiv$ or $V \approx$ position.

Rotary selector switch position $M\Omega_{ISO}$ is intended solely for the detection of interference voltage.

15 RS 232 C Interface

The cable multimeter is equipped with an infrared serial interface for the transmission of measurement data to data processing systems. Measurement data are transferred optically through the instrument housing by means of infrared light to an interface adapter (accessory), which is attached to the multimeter. Data are then forwarded to the computer via an RS 232 cable.

Activating the Interface

⇒ While switching the instrument on, simultaneously press the ON/OFF and DATA/MIN/MAX keys.

Automatic instrument shutdown is disabled after the interface has been activated. The  symbol (8) blinks at the LCD in order to indicate this condition.

The DATA function cannot be activated.

Accessory Interface Packs

Interface adapters without memory allow for the transmission of measurement data from as many as two multimeters to a PC.

Memory adapters also allow for on-site storage of measurement data without a PC, and subsequent downloading to a PC. Up to ten multimeters can be interconnected off-line for the creation of a high performance measuring system. Up to six multimeters can be connected to a PC for online operation via memory adapters (single-channel or 4-channel memory pack).

All interface packs include adapters, all necessary connector cables and METRAWin 10 data logging and analysis software with operating instructions.

16 Characteristic Values

Measuring Function	Measuring Range	Resolution	Input Impedance
V \equiv	30.00 mV	10 μ V	>10 G Ω // < 40 pF
	300.0 mV	100 μ V	>10 G Ω // < 40 pF
	3.000 V	1 mV	11 M Ω // < 40 pF
	30.00 V	10 mV	10 M Ω // < 40 pF
	300.0 V	100 mV	10 M Ω // < 40 pF
	600 V	1 V	10 M Ω // < 40 pF
V \sim ¹⁾	3.000 V	1 mV	11 M Ω // < 40 pF
	30.00 V	10 mV	10 M Ω // < 40 pF
	300.0 V	100 mV	10 M Ω // < 40 pF
	600 V	1 V	10 M Ω // < 40 pF
V \approx ¹⁾	3.000 V	1 mV	11 M Ω // < 40 pF
	30.00 V	10 mV	10 M Ω // < 40 pF
	300.0 V	100 mV	10 M Ω // < 40 pF
	600 V	1 V	10 M Ω // < 40 pF
A \sim ²⁾	30/100 A	10/100mA	—
			Open-circuit voltage
Ω	30.00 Ω	10 m Ω	max. 3.2 V
	300.0 Ω	100 m Ω	max. 3.2 V
	3.000 k Ω	1 Ω	max. 1.25 V
	30.00 k Ω	10 Ω	max. 1.25 V
	300.0 k Ω	100 Ω	max. 1.25 V
	3.000 M Ω	1 k Ω	max. 1.25 V
	30.00 M Ω	10 k Ω	max. 1.25 V
\rightarrow	2.000 V	1 mV	max. 3.2 V

Measuring Function	Measuring Range	Resolution	Discharge Resistance	U_0 max
F	30.00 nF	10 pF	250 k Ω	2.5 V
	300.0 nF	100 pF	25 k Ω	2.5 V
	3.000 μ F	1 nF	25 k Ω	2.5 V
			f_{\min} V \equiv	f_{\min} V \sim
Hz	300.0 Hz	0.1 Hz	1 Hz	45 Hz
	3.000 kHz	1 Hz	1 Hz	45 Hz
	30.00 kHz	10 Hz	10 Hz	45 Hz
	100.0 kHz	100 Hz	100 Hz	100 Hz
$^{\circ}$C	Pt 100	- 200.0 ... + 200.0 $^{\circ}$ C	0.1 $^{\circ}$ C	—
		+ 200.0 ... + 800.0 $^{\circ}$ C	0.1 $^{\circ}$ C	—
	Pt 1000	- 100.0 ... + 200.0 $^{\circ}$ C	0.1 $^{\circ}$ C	—
		+ 200.0 ... + 800.0 $^{\circ}$ C	0.1 $^{\circ}$ C	—
$^{\circ}$F	Pt 100	- 300.0 ... + 400.0 $^{\circ}$ C	0.1 $^{\circ}$ F	—
		+ 400.0 ... + 999.0 $^{\circ}$ C	0.1 $^{\circ}$ F	—
	Pt 1000	- 145.0 ... + 400.0 $^{\circ}$ C	0.1 $^{\circ}$ F	—
		+ 400.0 ... + 999.0 $^{\circ}$ C	0.1 $^{\circ}$ F	—

¹⁾ TRMS measurement

²⁾ Measurement with type WZ12B clip-on current sensor

Measuring Function	Measuring Range		Digital Display Intrinsic Error $\pm(\dots \% \text{ of rdg.} + \dots \text{ digits})$ under Reference Conditions	Overload Capacity ¹⁾	
				Value	Time
V \equiv	30.00 mV		$0.5 + 3^{2)}$	600 V DC	Cont.
	300.0 mV		$0.5 + 3$		
	3.000 V		$0.5 + 1$		
	30.00 V		$0.5 + 1$		
	300.0 V		$0.5 + 1$		
	600 V		$0.5 + 1$		
V \sim	3.000 V		$1.5 + 3 (> 10 \text{ digits})$	AC eff sine	Cont.
	30.00 V				
	300.0 V				
	600 V				
V \approx	3.000 V		$1.5 + 3 (> 10 \text{ digits})$		
	30.00 V				
	300.0 V				
	600 V				
A $\sim \infty$	100 A		$2.5 + 3 (> 10 \text{ digits})$	120 A	Cont.
Ω	30.00 Ω		$0.5 + 3^{2)}$	600 V DC AC eff sine	max. 10 s
	300.0 Ω		$0.5 + 3$		
	3.000 k Ω		$0.5 + 1$		
	30.00 k Ω		$0.5 + 1$		
	300.0 k Ω		$0.5 + 1$		
	3.000 M Ω		$0.6 + 1$		
	30.00 M Ω		$2.0 + 1$		
\rightarrow	2.000 V		$0.5 + 1$		

Measuring Function	Measuring Range		Digital Display Intrinsic Error $\pm(\dots \% \text{ of rdg.} + \dots \text{ digits})$ under Reference Conditions	Overload Capacity ¹⁾	
				Value	Time
F	30.00 nF		$1.0 + 3^{3)}$	600 V DC / AC eff sine	max. 10 s
	300.0 nF		$1.0 + 3$		
	3.000 μ F		$1.0 + 3$		
Hz	300.0 Hz		$0.5 + 1^{4)}$	$\leq 600 \text{ V}$	Cont.
	3.000 kHz				
	30.00 kHz		$0.5 + 1^{4)}$	$\leq 300 \text{ V}$	
	100.0 kHz		$0.5 + 1^{5)}$	$\leq 30 \text{ V}$	
$^{\circ}$C	Pt 100	$-200.0 \dots +200.0 \text{ }^{\circ}\text{C}$	2 Kelvin + 5 digits ⁶⁾	600 V DC AC eff sine	max. 10 s
		$+200.0 \dots +800.0 \text{ }^{\circ}\text{C}$	$1.0 + 5^{6)}$		
	Pt 1000	$-100.0 \dots +200.0 \text{ }^{\circ}\text{C}$	2 Kelvin + 5 digits ⁶⁾		
		$+200.0 \dots +800.0 \text{ }^{\circ}\text{C}$	$1.0 + 5^{6)}$		
$^{\circ}$F	Pt 100	$-300.0 \dots +400.0 \text{ }^{\circ}\text{C}$	4 Kelvin + 10 digits ⁶⁾	600 V DC AC eff sine	max. 10 s
		$+400.0 \dots +999.0 \text{ }^{\circ}\text{C}$	$1.0 + 10^{6)}$		
	Pt 1000	$-145.0 \dots +400.0 \text{ }^{\circ}\text{C}$	4 Kelvin + 10 digits ⁶⁾		
		$+400.0 \dots +999.0 \text{ }^{\circ}\text{C}$	$1.0 + 10^{6)}$		

1) At $-20 \text{ }^{\circ}\text{C} \dots +40 \text{ }^{\circ}\text{C}$

2) Without zero balancing: +35 digits,

3) Without zero balancing: +50 digits

4), 5) Range **3 V** \approx : ⁴⁾ $U_E = 1.5 V_{\text{eff}} \dots 100 V_{\text{eff}}$ ⁵⁾ $U_E = 2.5 V_{\text{eff}} \dots 30 V_{\text{eff}}$

30 V \approx : ⁴⁾ $U_E = 15 V_{\text{eff}} \dots 300 V_{\text{eff}}$ ⁵⁾ $U_E = 25 V_{\text{eff}} \dots 30 V_{\text{eff}}$

300 V \approx : ⁴⁾ $U_E = 150 V_{\text{eff}} \dots 600 V_{\text{eff}}$ —

6) Without sensor

Insulation Resistance Measurement

Measuring Function, Switch Setting	Measuring Range	Resolution	Digital Display Intrinsic Error under Reference Conditions
$U_{INT}/M\Omega_{ISO}$	0 ... 110 V $\overline{\sim}$	0.1 V	$\pm(3\% \text{ rdg.} + 10 \text{ d})$
$M\Omega_{ISO}$ ($U_N = 100 \text{ V}$)	0.005 ... 0.310 $M\Omega$ *	1 $k\Omega$	$\pm(3\% \text{ rdg.} + 5 \text{ d})$
	0.280 ... 3.100 $M\Omega$	1 $k\Omega$	$\pm(3\% \text{ rdg.} + 2 \text{ d})$
	02.80 ... 3.100 $M\Omega$	10 $k\Omega$	
	028.0 ... 310.0 $M\Omega$	100 $k\Omega$	

* Where $R < 100 \text{ k}\Omega$, ERROR is displayed first.

Measuring Function, Switch Setting	Nominal Voltage U_N	Open-Circuit Voltage U_0	Nominal Current I_N	Short-Circuit Current I_k
$M\Omega_{ISO}$	100 V	max 130 V	$>1.0 \text{ mA}$	$< 1.5 \text{ mA}$

Measuring Function, Switch Setting	Nominal Voltage U_N	Acoustic Signal where	Overload Capacity	
			Value	Time
$U_{INT}/M\Omega_{ISO}$	—	$U > 110 \text{ V}$	600 V $\overline{\sim}$	Continuous
$M\Omega_{ISO}$	100 V	$U > 110 \text{ V}$	600 V $\overline{\sim}$	10 s

Influencing Quantities and Influence Error

Influencing Quantity	Sphere of Influence	Measured Qty. / Measuring Range	Influence Error ¹⁾ $\pm(\dots \% \text{ rdg.} + \dots \text{ digits})$
Temp.	0 °C ... +21 °C and +25 °C ... +40 °C	30/300 mV $\overline{\sim}$	1.0 + 3
		3 ... 300 V $\overline{\sim}$	0.15 + 1
		600 V $\overline{\sim}$	0.2 + 1
		V \sim	0.4 + 2
		30 Ω ²⁾	0.15 + 2
		300 Ω	0.25 + 2
		3 $k\Omega$... 3 $M\Omega$	0.15 + 1
		30 $M\Omega$	1.0 + 1
		30 nF ²⁾ /3 μF	2 + 2
		Hz	0.5 + 1
		- 200 ... + 200 °C	0.5 K + 2
		+ 200 ... + 800 °C	0.5 + 2
		- 300 ... + 400 °F	1.0 K + 4
		+ 400 ... + 999 °F	0.5 + 2
$M\Omega_{ISO}$	1.0 + 2		
Measured Quantity Frequency	15 Hz ... < 30 Hz	3 ... 600 V \sim	1.0 + 3
	30 Hz ... < 45 Hz		0.5 + 3
	> 65 Hz ... 400 Hz		2.0 + 3
	> 400 Hz ... 1 k Hz		3.0 + 3

Influencing Quantity	Sphere of Influence		Measured Qty. / Measuring Range	Influence Error ¹⁾ ± (... % rdg. + ... digits)
	Crest Factor CF	1 ... 3	$V \sim$ ⁴⁾	±1% rdg.
		> 3 ... 5		±3% rdg.
Allowable crest factor CF of the periodic quantity to be measured is dependent upon the displayed value:				
Measured Quantity Wave-shape ³⁾				

- 1) For temperature: specified error valid for temperature changes as of 10 K.
For frequency: specified error valid for display values as of 300 digits.
- 2) With zero balancing
- 3) In the case of unknown waveshapes (crest factor CF > 2), measurement must be performed using manual range selection.
- 4) Except for sinusoidal waveshape

Influencing Quantity	Sphere of Influence	Measured Qty. / Measuring Range	Influence Error
Battery Voltage	\pm ¹⁾ ... < 7.9 V > 8.1 V ... 10.0 V	$V \equiv$	±2 digits
		$V \sim$	±4 digits
		30 Ω /300 Ω /°C/ °F	±4 digits
		3 k Ω ... 30 M Ω	±3 digits
		M Ω _{ISO}	±2 digits
		nF, μ F	±1 digit
		Hz	±1 digit
Relative Humidity	75% 3 days instrument off	$V \approx$ Ω M Ω _{ISO} Hz	1 x intrinsic error
DATA	—	°C, °F	±1 digit
MIN / MAX	—	$V \approx$	±2 digit

- 1) After the \pm symbol appears at the display

Influencing Quantity	Sphere of Influence	Measuring Range	Damping
Common Mode Interference Voltage	Interference quantity max. 600 V \sim	$V \equiv$	> 120 dB
	Interference quantity max. 600 V \sim 50 Hz, 60 Hz sine	3 V \sim , 30 V \sim	> 80 dB
		300 V \sim	> 70 dB
		600 V \sim	> 60 dB
Series Mode Interference Voltage	Interference quantity: V \sim , respective nominal value of the measuring range, max. 600 V 0 \sim , 50 Hz, 60 Hz sine	$V \equiv$	> 50 dB
	Interference quantity max. 600 V —	$V \sim$	> 110 dB

Response Time (after manual range selection)

Measured Qty. / Measuring Range	Response Time		Measured Quantity Step Function
	Analog Display	Digital Display	
V $\overline{\text{---}}$, V \sim	0.7 s	1.5 s	from 0 to 80% of upper range limit
30 Ω ... 3 M Ω	1.5 s	2 s	from ∞ to 50% of upper range limit
30 M Ω	4 s	5 s	
\rightarrow	0.7 s	1.5 s	
nF, μ F, °C, °F		max. 1 ... 3 s	from 0 to 50% of upper range limit
300 Hz, 3 kHz		max. 2 s	
30 kHz		max. 0.7 s	

Reference ConditionsAmbient temperature +23 °C \pm 2 K

Relative humidity 40% ... 60%

Measured quantity
frequency 45 Hz ... 65 Hz

Measured quantity

waveshape sinusoidal

Battery voltage 8 V \pm 0.1 V**Display**

LCD panel (65 mm x 30 mm) with analog and digital displays including unit of measure, type of voltage and various special functions

Analog

Display LCD scale with pointer

Scale length 55 mm for V $\overline{\text{---}}$,
47 mm in all other rangesScaling Linear (ranges other than M Ω_{ISO}):
 \mp 5 ... 0 ... \pm 30 with 35 scale divisions
for $\overline{\text{---}}$, 0 ... 30 with 30 scale divisions
in all other rangesLogarithmic M Ω_{ISO} range):... \leq 0.3 ... 3 ... 30 ... 300,

bar graph instead of pointer

Polarity display With automatic switching

Overflow display Triangle (13)

Measuring rate 20 measurements per second,
for Ω : 10 measurements per second

Digital

Display/char. height 7-segment characters / 15 mm

Number of places $3\frac{3}{4}$ places \triangleq 3100 steps

Overflow display "OL" appears

Polarity display "-" sign is displayed if plus pole is
connected to \perp Measuring rate 2 measurements per second,
for Ω and °C: 1 measurement per second**Electrical Safety**

Safety class II per EN 61010-1:2001/VDE 0411-1:2002

Measuring category II

Nominal voltage 600 V

Fouling factor 2

Test voltage 3.5 kV \sim per EN 61010-1:2001
/VDE 0411-1:2002

Power Supply

Battery

9 V flat-cell battery,
alkaline manganese per IEC 6 LR 61

Measuring Function	Nominal Voltage U_N	DUT Resistance	Service Life in Hours	Number of Possible Measurements with Nominal Current (1 mA) ²⁾
V \equiv			500 ¹⁾	
V \sim			100 ¹⁾	
M Ω _{ISO}	100 V	1 M Ω	50	
	100 V	100 k Ω		3000

1) Times 0.7 for interface operation, times 0.2 with illumination

2) Battery depletion warning: + is displayed automatically if battery voltage drops to below approximately 7 V.

EMC

Interference emission

Electromagnetic Compatibility

EN 61326:2002 class B

Interference immunity

EN 61326:2002

EN 61000-4-2:1995/A1:1998

Feature A: 8 kV atmospheric discharge / 4 kV contact discharge

EN 61000-4-3:1995/A1:1998

Feature B: 3 V/m

Interface

Type

RS 232 C, serial, per DIN 19241

Data transmission

Optical via infrared light through housing

Baud rate

8192 bits per second

Ambient Conditions

Accuracy

0 °C ... + 40 °C

Operating temperature

-10 °C ... + 50 °C

Storage temperature

-25 °C ... + 70 °C (without battery)

Relative humidity

≤ 75%, no condensation allowed

Elevation

to 2000 m

Deployment

Indoors only, except within specified ambient conditions

Mechanical Design

Dimensions

84 mm x 195 mm x 35 mm

Weight

approx. 0.35 kg with battery

Protection

Housing: IP 54, connector jacks: IP 20

Extract from table on the significance of IP codes

IP XY (1 st digit X)	Protection against the penetration of solid foreign matter	IP XY (2 nd digit Y)	Protection against the penetration of water
0	no protection	0	no protection
1	≥ 50.0 mm Ø	1	vertical dripping
2	≥ 12.5 mm Ø	2	dripping (15° gradient)
3	≥ 2.5 mm Ø	3	spray-water
4	≥ 1.0 mm Ø	4	splashwater
5	protection from dust	5	hoseproof



Important!

Disconnect the instrument from the measuring circuit before opening to replace the battery!

17.1 Battery

Make sure that no battery leakage has occurred before initial start-up, and after long periods of storage. Continue to inspect the batteries for leakage at short, regular intervals. If battery leakage has occurred, carefully and completely clean the electrolyte from the instrument with a damp cloth, and replace the batteries before using the instrument.

If the + symbol (17) appears at the display (1), the batteries should be replaced as soon as possible. You can continue working with the instrument, but reduced measuring accuracy may result.

The instrument requires one 9 V flat-cell battery per IEC 6 LR 61. Use only alkaline manganese batteries in accordance with IEC 6 LR61.

Replacing the Battery

- Set the instrument face down onto a flat working surface, loosen the two screws at the back and lift off the housing base, starting at the bottom (a). The housing top and housing base are held together with the help of snap hooks at the top front.
- Remove the batteries from the battery compartment and carefully disconnect the snap contacts from the battery.
- Snap the contacts onto a new 9 V battery and insert it into the battery compartment.
- Important for reassembly: First set the housing base onto the housing top and align accurately (see photo below). Then press the two housing halves together, first at the bottom front (a), and then at the top front (b).



- Secure the housing base with the two screws.
- Please dispose of depleted batteries in accordance with environmental protection regulations!

17.2 Housing

No special maintenance is required for the housing. Keep outside surfaces clean. Use a slightly dampened cloth for cleaning. Avoid the use of solvents, cleansers and abrasives.

18 Repair and Replacement Parts Service DKD Calibration Lab * and Rental Instrument Service

The measuring instrument is shipped from the factory with a DKD calibration certificate. First re-calibration is recommended 12 months after initial start-up.

If required please contact:

GOSSEN METRAWATT GMBH
Service Center
Thomas-Mann-Str. 20
90471 Nürnberg, Germany
Phone +49-(0)-911-8602-0
Fax +49-(0)-911-8602-253
E-Mail service@gossenmetrawatt.com

This address is only valid in Germany.

Please contact our representatives or subsidiaries for service in other countries.

* **DKD** Calibration Laboratory for Electrical Quantities DKD – K – 19701 accredited per DIN EN ISO/IEC 17025

Accredited quantities: direct voltage, direct current value, direct current resistance, alternating voltage, alternating current value, alternating current active power, alternating current apparent power, DC power, capacitance, frequency

Competent Partner

GOSSEN METRAWATT GMBH is certified in accordance with DIN EN ISO 9001:2000.

Our DKD calibration laboratory is accredited by the Physikalisch Technische Bundesanstalt (*German Federal Institute of Physics and Metrology*) and the Deutscher Kalibrierdienst (*German Calibration Service*) in accordance with DIN EN ISO/IEC 17025 by under registration number DKD-K-19701.

We offer a complete range of expertise in the field of metrology: from **test reports** and **proprietary calibration certificates** right on up to **DKD calibration certificates**.

Our spectrum of offerings is rounded out with free **test equipment management**.

An **on-site DKD calibration station** is an integral part of our service department. If errors are discovered during calibration, our specialized personnel are capable of completing repairs using original replacement parts.

As a full service calibration laboratory, we can calibrate instruments from other manufacturers as well.

DKD Calibration Certificate Reprints

If you order a DKD calibration certificate reprint for your instrument, please provide us with the reference numbers included in the upper and lower most fields of the calibration seal. We do not need the instrument's serial number.

19 Guarantee

All METRA HIT measuring and calibration instruments are guaranteed for a period of 3 years from date of shipment. Calibration is guaranteed for a period of 12 months. The guarantee covers materials and workmanship. Any damage resulting from use for any other than the intended purpose, as well as any and all follow-up costs, are excluded.

20 Product Support

If required please contact:

GOSSEN METRAWATT GMBH
Product Support Hotline
Phone +49-(0)-911-8602-112
Fax +49-(0)-911-8602-709
E-Mail support@gossenmetrawatt.com

Edited in Germany • Subject to change without notice
• A pdf version is available on the internet

GOSSEN METRAWATT GMBH
Thomas-Mann-Str. 16-20
90471 Nürnberg • Germany
Phone +49-(0)-911-8602-0
Fax +49-(0)-911-8602-669
E-Mail info@gossenmetrawatt.com
www.gossenmetrawatt.com