

R2080, R2100, R2180

Compact Controller 96 x 96 mm

3-349-219-15

4/5.09

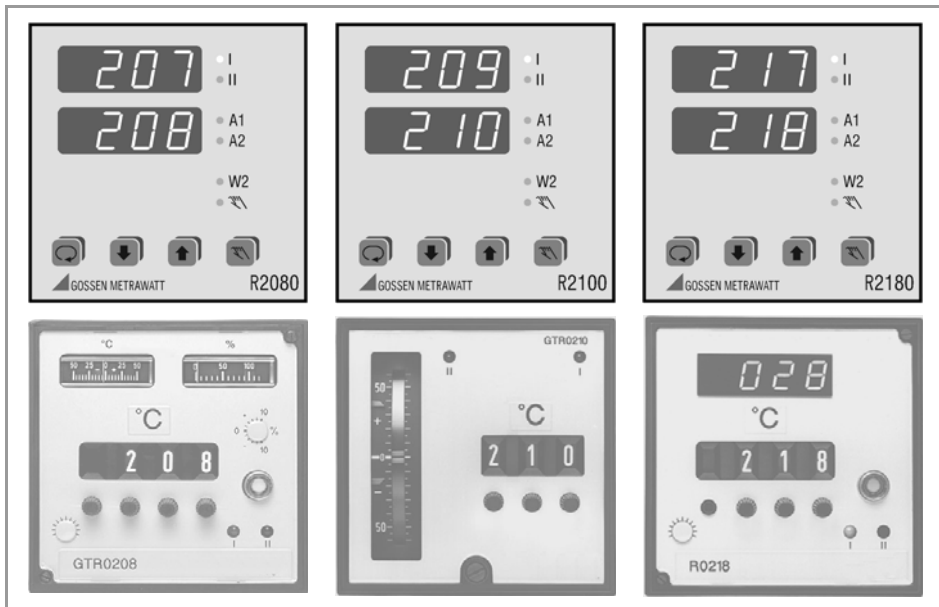

Safety Features and Precautions 3

Maintenance 3

Repair and Replacement Parts Service 4

Product support 4

Identification of Controller R2080 5

Identification of Controller R2100 6

Identification of Controller R2180 7

Mechanical Installation / Preparation 8

Differences between R2080/R2100/R2180 and
GTR0208/GTR0210/GTR0218 9

Connection R2080 10

Connection R2100 11

Connection R2180 12

Electrical Connection 13

Performance After Activating Auxiliary Voltage 13

Display – Setpoint Selection – Operation 14

Operating Flowchart 15

Parameters Configuration 16

Limit Value Monitoring 17

Adjusting Control Performance – Manual Self-Tuning 18

Self-Tuning 21

Alarms 22

Error Messages 22

Setpoint Ramps 24

Balancing 24

Configuration 25

Saving and Loading Device Settings 28

Exchange of Setpoint with Binary Input 29

Manual Operation with Binary Input 29

PWR Out Offset with Binary Input29

Heating Current Monitoring30

Heating Circuit Monitoring30

Technical Data31

Meanings of symbols on the instrument



Indicates EC conformity



Continuous doubled or reinforced insulation



Warning concerning a source of danger
Attention: observe documentation!



Functional earth terminal,
earthing for functional purposes only
(no safety function)

Safety Features and Precautions

The R2XX0 controllers are manufactured and tested in accordance with safety regulations IEC 61010-1 / DIN EN 61010-1 / VDE 0411-1.

If used for its intended purpose, safety of the user and of the device is assured.

Read the operating instructions completely and carefully before using the device, and follow all instructions included therein. The operating instructions should be made available to all users.

Observe the following safety precautions:

- The device may only be connected to electrical systems which comply with the specified nominal range of use (see circuit diagram and serial plate), and which are protected with a fuse or circuit breaker with a maximum nominal current rating of 16 A.
- The installation must include a switch or a circuit breaker which serves as a disconnecting device.

The controller may not be used:

- If visible damage is apparent
- If it no longer functions flawlessly
- After lengthy periods of storage under unfavorable conditions (e.g. humidity, dust, temperature)

In such cases the device must be removed from service and secured against any possible inadvertent use.

Maintenance

Housing

No special maintenance is required for the housing. Keep outside surfaces clean. Use a slightly dampened cloth for cleaning. Avoid the use of solvents, cleansers and abrasives.

Repair and Parts Replacement

Repairs and the replacement of parts conducted at a live open instrument may only be carried out by trained personnel who are familiar with the dangers involved.

Repair and Replacement Parts Service

When you need service, please contact:

GMC-I Service GmbH
Service Center
Thomas-Mann-Str. 20
90471 Nürnberg, Germany
Phone: +49 911 817718-0
Fax: +49 911 817718-253
E-Mail: service@gossenmetrawatt.com

This address is only valid in Germany.

Please contact our representatives or subsidiaries for service in other countries.

Product support

When you need support, please contact:

GMC-I Messtechnik GmbH
Product Support Hotline
Phone: +49 911 8602-500
Fax: +49 911 8602-340
E-Mail support@gossenmetrawatt.com

Identification of Controller R2080

Feature	Designation	
Electronic PDPI controller	R2080	
Controller types		
2-step controller medium time response	A01	
2-step controller with limit contact medium time response	A02	
3-step controller medium time response	A04	
2-step controller short time response	A11	
2-step controller with limit contact short time response	A12	
3-step controller short time response	A14	
without feedback with 1 limit contact	A21	
without feedback with 2 limit contacts	A22	
Measuring ranges		
Thermocouple type L Fe-CuNi	0 ... 200 °C	C01
	0 ... 400 °C	C02
	0 ... 600 °C	C03
type J Fe-CuNi	0 ... 200 °C	C04
	0 ... 400 °C	C05
	0 ... 600 °C	C06
type K NiCr-Ni	0 ... 800 °C	C07
	0 ... 400 °C	C08
	0 ... 600 °C	C09
type R Pt13Rh-Pt	0 ... 800 °C	C10
	0 ... 1200 °C	C11
	0 ... 1600 °C	C12
type S Pt10Rh-Pt	0 ... 1600 °C	C13
Resistance thermometer Pt100	0 ... 100 °C	C20
	0 ... 200 °C	C21
	0 ... 400 °C	C22
	-100 ... +100 °C	C24
	-100 ... +200 °C	C25
Output type 1st switching point		
Relay	D1	
Transistor	D2	

Features A3, A13, C23 and E3 of controller GTR0208 **cannot be replaced.**

Feature B2 is **not compatible** with GTR0208.

Auxiliary voltage is generally AC 110 ... 230 V.

A switch to deactivate the control outputs is always available (see feature F1 of controller GTR0208).

Generally, the actual value and the setpoint value and/or heating current are indicated.

As a rule, setpoint limiting is available.

Identification of Controller R2100

Feature	Designation	
Electronic PDPI controller	R2100	
Controller types		
2-step controller	A1	
3-step controller	A2	
Time response		
medium	XB0	
short	XB1	
long	XB2	
Measuring range		
Thermocouple type L Fe-CuNi	0 ... 400 °C	C01
	0 ... 800 °C	C02
type J Fe-CuNi	0 ... 400 °C	C03
	0 ... 400 °C	C05
type K NiCr-Ni	0 ... 600 °C	C06
	0 ... 800 °C	C07
	0 ... 1200 °C	C08
type R Pt13Rh-Pt	0 ... 1600 °C	C09
	0 ... 1600 °C	C10
Resistance thermometer Pt100	0 ... 100 °C	C20
	0 ... 200 °C	C21
	0 ... 400 °C	C22
	-100 ... +200 °C	C24
Direct current	0 ... 5 mA	C30
	0 ... 20 mA	C31
	0 ... 20 mA, display 0.00 ... 2.00	C32
Output type 1st switching point		
Relay	D1	
Transistor	D2	
Limit contact		
none	G0	
MIN / MAX	G1	
Rupture protection		
direct action	XH0	
reverse action	XH1	

Features C23 and E5 of controller GTR0210 **cannot be replaced**.

Auxiliary voltage is generally AC 110 ... 230 V.
A switch to deactivate the control outputs and a switching facility for the display is always available (see features F1 and F2 of controller GTR0210).

Identification of Controller R2180

Feature	Designation	
Electronic PDPI controller	R2180	
Controller types		
2-step controller	A1	
3-step controller	A2	
2-step controller with MAX limit contact	A3	
2-step controller with MAX / MIN limit contact	A4	
Time response		
short	B1	
medium	B2	
long	B3	
Measuring range		
Thermocouple °C type L Fe-CuNi	0 ... 199 °C	C01
	0 ... 399 °C	C02
	0 ... 599 °C	C03
	type J Fe-CuNi	0 ... 199 °C
	0 ... 399 °C	C05
	0 ... 599 °C	C06
	32 ... 392 °F	C13
	32 ... 752 °F	C14
	32 ... 1112 °F	C15
type K NiCr-Ni	0 ... 399 °C	C07
	0 ... 599 °C	C08
	0 ... 799 °C	C09
	0 ... 1200 °C	C10
	32 ... 752 °F	C16
	32 ... 1112 °F	C17
	32 ... 1472 °F	C18
	32 ... 2192 °F	C19
type R Pt13Rh-Pt	0 ... 1600 °C	C11
	32 ... 2912 °F	C20
type S Pt10Rh-Pt	0 ... 1600 °C	C12
	32 ... 2912 °F	C21

Feature	Designation	
Resistance thermometer Pt100	-99,9 ... +99,9 °C	C30
(2-wire connection)	-99,9 ... +199,9 °C	C31
	0 ... +99,9 °C	C32
	0 ... +199,9 °C	C33
	0 ... +399,9 °C	C34
	-148 ... +212 °F	C37
	-148 ... +392 °F	C38
	32 ... 212 °F	C39
	32 ... 392 °F	C40
	32 ... 752 °F	C41
Resistance thermometer Pt100	-99,9 ... +99,9 °C	C50
(3-wire connection)	-99,9 ... +199,9 °C	C51
	0 ... +99,9 °C	C52
	0 ... +199,9 °C	C53
	0 ... +399,9 °C	C54
	-148 ... +212 °F	C57
	-148 ... +392 °F	C58
	32 ... 212 °F	C59
	32 ... 392 °F	C60
	32 ... 752 °F	C61
Output type 1st switching point		
Relay		D1
Transistor		D2

Features C35, C42, C55, C62 and E1 of controller GTR0218 **cannot be replaced**.

Auxiliary voltage is generally AC 110 ... 230 V.

A switch to deactivate the control outputs is always available (see feature F1 of controller GTR0218).

Mechanical Installation / Preparation

The RXX0 controller is intended for installation to a control panel. The installation location should be vibration-free to the greatest possible extent. Aggressive vapors shorten the service life of the controller. Requirements set forth in VDE 0100 must be observed during the performance of all work. Work on the device may only be carried out by trained personnel who are familiar with the dangers involved.

Set the housing into the panel cutout from the front, and secure it from behind at the left and right-hand sides with the two included screw clamps.

Push the screw clamps first all the way up to the limit stop in direction 1 and subsequently in direction 2 for this purpose. Typical tightening torque amounts to 10 Ncm, and a value of 20 Ncm should not be exceeded.

In general, unobstructed air circulation must be assured when one or several devices are installed. The ambient temperature underneath the devices may not exceed 50 °C.

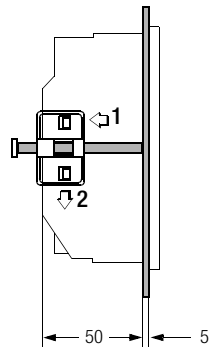
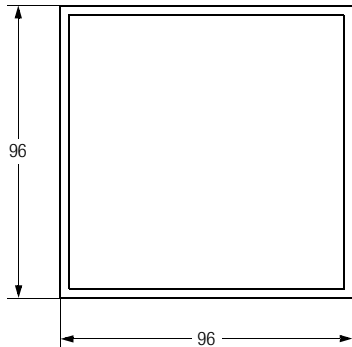

R2080, R2180 and R2100 G0

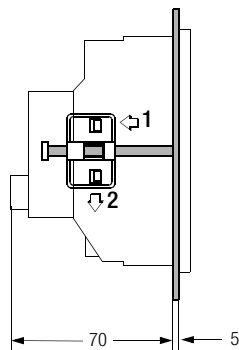
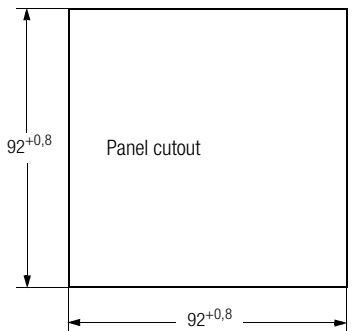

R2100 G1 only

Differences between R2080/R2100/R2180 and GTR0208/GTR0210/GTR0218

Controllers R2080, R2100 and R2180 do not supersede analog devices GTR0208, GTR0210 and GTR0218 in a fully compatible manner. Please note the following deviations:

Temperature sensor Pt100

As a rule, controllers R2080, R2100 and R2180 are provided with a 3-wire-connection.

Consequently, for Pt100 (but not in the case of a thermocouple), terminals 18-19 at controllers R2080 / R2100 or terminals 12-13 at controller R2180 must be shunted.

Sensor rupture protection

Controllers R2080, R2100 and R2180 are able to detect a broken sensor and/or polarity reversal of the sensor, whereupon the actuating outputs are deactivated and an alarm is triggered at the same time.

If the actuating outputs are to assume a certain status, it must be set with parameter *Y5E*.

Protective conductor connection

According to EMC requirements controllers R2080, R2100 and R2180 must be provided with a protective conductor connection.

Cooling output

In the case of 3-step controllers R2080 / R2180, the 2nd switching point cannot be used as an NC contact.

Limit contact

In the case of controller types R2080 / R2180 with limit contact, the configuration of the R2080 / R2180 must be changed from $\overline{LNF} / = 0xx0$ to $0xx4$ while using the break contact (reverse action principle). Switching point distance Δw can only be set as a relative MAX alarm to a value above zero for the R2080 / R2180.

Heating current display / monitoring

Heating current transformer GTY 2570 127 R0x can no longer be used in connection with R2080.

Instead, 3-input and/or 4-input current transformers GTZ 4121 must be fitted for acquiring heating current.

This offers the additional feature of not only indicating the heating current but also monitoring antivalence provided the R2080 has been appropriately set. In this case, an alarm is triggered if current is too low while heating is activated or if current is not „off“ while heating is deactivated (see also page 30).

RC elements

In contrast to GTR0210, no RC elements for spark suppression have been fitted in controllers R2080, R2100 and R2180. It is therefore recommended retrofitting the controlled actuators (contactors, solenoid valves, etc.) with the associated RC elements.

Connection R2080

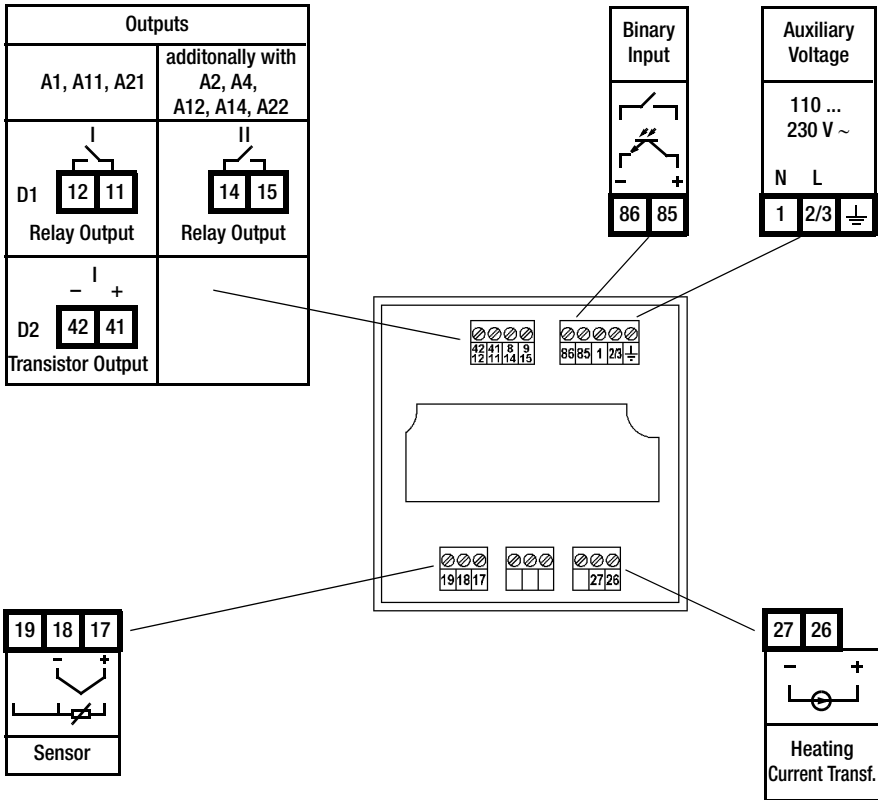

Connection R2100

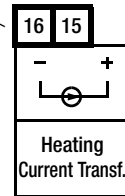
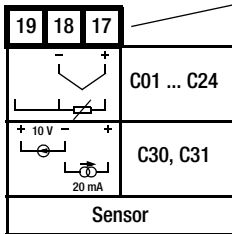
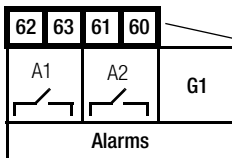
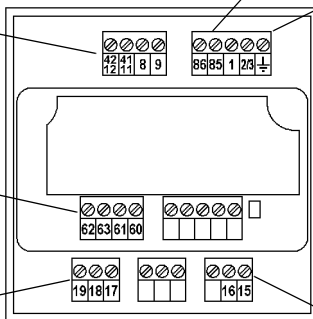
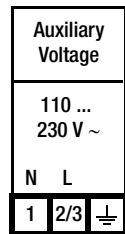
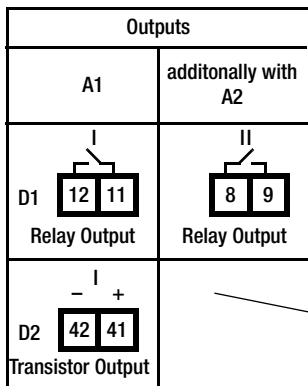

Connection R2180

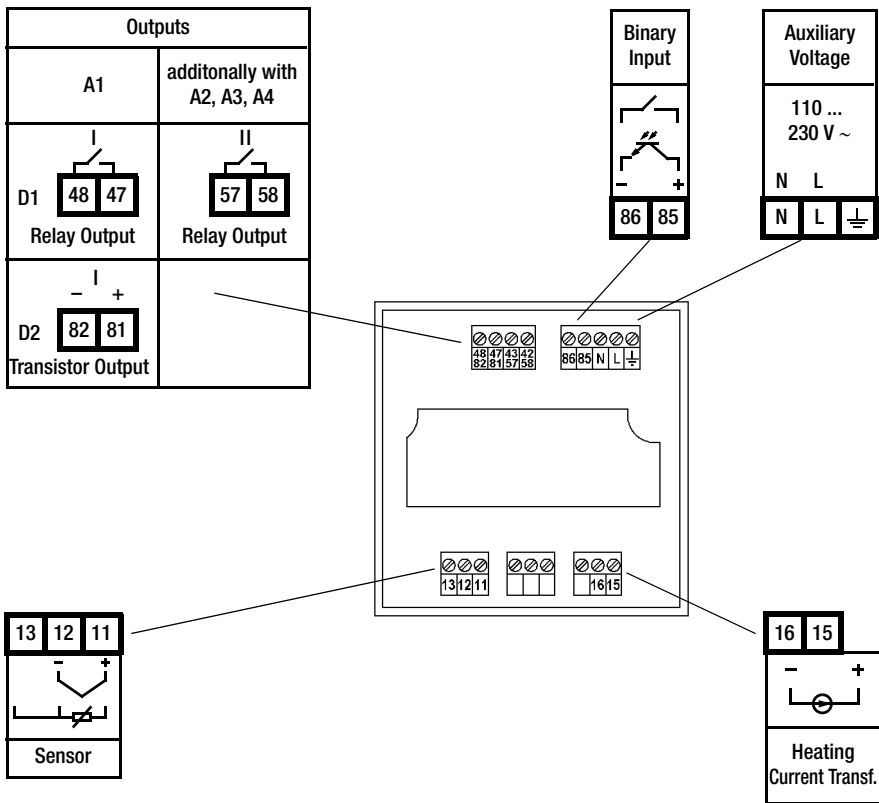

Electrical Connection

Connectors: Screw terminals for wire with a cross section of 1.5 square mm or two-core wire-end ferrules with a cross-section of 2 x 0.75 square mm

Tighten screws with a manual screwdriver only! Tightening torque for all screw terminals: max. 0.6 Nm

EN 55022 requires the following warning as regards electromagnetic compatibility:

Warning

This is a class A device. It may cause radio interference in residential surroundings. If this is the case, the operator may be required to implement appropriate corrective measures.

Performance After Activating Auxiliary Voltage

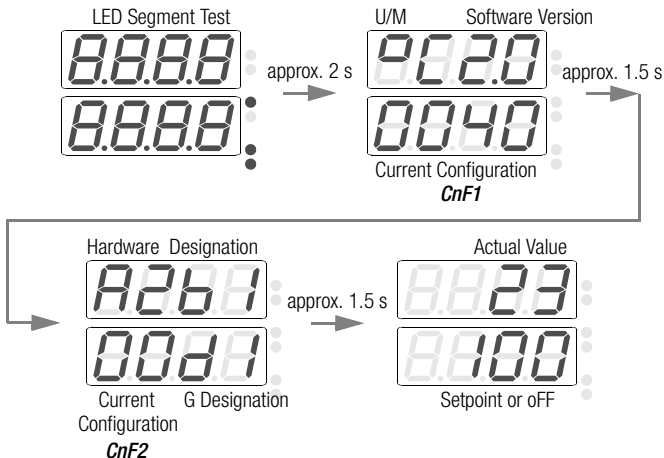

Display – Setpoint Selection – Operation

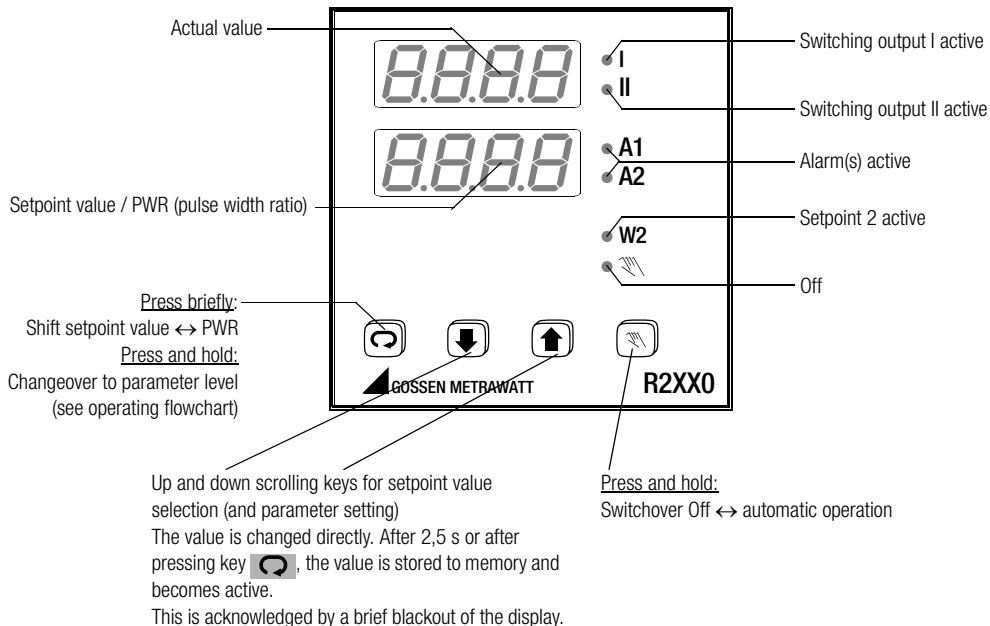

Operating Flowchart

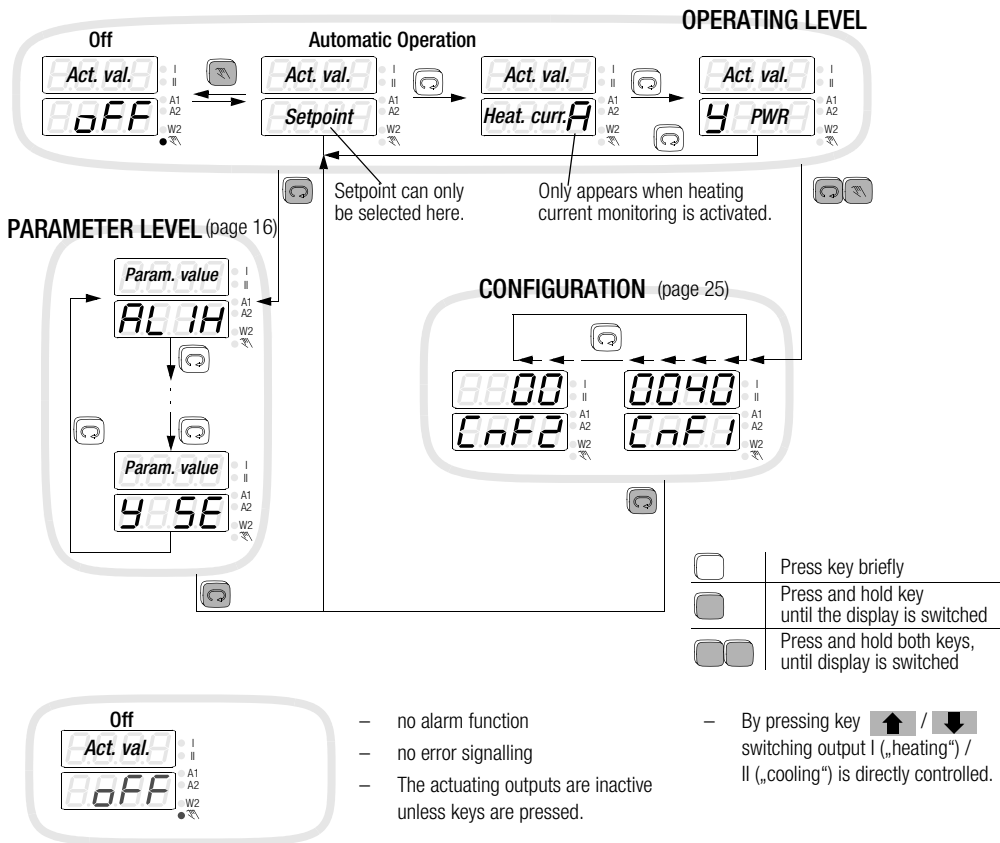

Parameters Configuration

X1 = lower range limit, X2 = upper range limit, MBU = X2 - X1. These values refer to the configured sensor type (see Configuration page 25), **not** to the C Designation.

Parameter	Display	Range	Default	Comment
Upper limit value for relay A1	<i>AL 1H</i>			
Lower limit value for relay A1	<i>AL 1L</i>	oFF, 1 ... MBU	oFF / *	Relative (= default config.)
Upper limit value for relay A2	<i>AL 2H</i>	oFF, X1 ... X2	oFF / *	Absolute
Lower limit value for relay A2	<i>AL 2L</i>			
Setpoint 2	<i>SP 2</i>	<i>SPL ... SPH</i>	X1	
Ramp for rising setpoints	<i>SP uP</i>	oFF, 1 ... MBU pro min	oFF	
Ramp for falling setpoints	<i>SP d n</i>	oFF, 1 ... MBU pro min	oFF	
Heating current setpoint (see Balancing)	<i>ANPS</i>	Auto, oFF, 0.1 ... <i>AH</i>	oFF	Not with step-action controllers ¹⁾
Proportional band heating	<i>Pb 1</i>	0.1 ... 999.9 %	10.0 / *	
Proportional band cooling	<i>Pb 11</i>	0.1 ... 999.9 %	10.0 / *	Only with 3-step controllers ²⁾
Dead band	<i>dbnd</i>	0 ... MBU	0	Not with 2-step controllers ³⁾
Path delay time	<i>t u</i>	0 ... 9999 s	100 / *	
Read-out cycle time	<i>t c</i>	0.5 ... 600.0 s	10.0 / *	
Motor run-time	<i>t y</i>	5 ... 5000 s	60	Only with step-action controllers ⁴⁾
Switching hysteresis	<i>HYS t</i>	0 ... 1,5%MBU	0,5%MBU / *	For limit value monitoring and limit transducers
Maximum setpoint	<i>SP H</i>	<i>SPL ... X2</i>	X2 / *	
Minimum setpoint	<i>SP L</i>	X1 ... <i>SPH</i>	X1 / *	
Maximum PWR	<i>y H</i>	-100 ... 100 %	100	
Actual value correction (see Balancing)	<i>CAL</i>	(Auto), -MBU/4 ... +MBU / 4	0 / *	Only with designations C01 ... C24

Parameter	Display	Range	Default	Comment
Decimal point position	<i>dPnt</i>	9999, 999•9, 99•99, 9•999	9999 / *	only for designations C30, C31
Upper range limit, standard signal	<i>rn H</i>	<i>rnL</i> ... 9999	100 / *	
Lower range limit, standard signal	<i>rn L</i>	-1500 ... <i>rnH</i>	0	
Upper range limit, heating current (see Balancing)	<i>A H</i>	1.0 ... 99.9 A	42,7	not with step-action controllers ¹⁾
PWR for actuator mode, or for PWR out offset	<i>y St</i>	-100 ... 100 %	0	
Sensor error PWR	<i>y SE</i>	-100 ... 100 %	0 / *	

¹⁾ only where: "controller sort" configuration digit ≠ 6

²⁾ only where: "controller sort" configuration digit = 4 or 5

³⁾ only where: "controller sort" configuration digit = 0, 4, 5 or 6

⁴⁾ only where: "controller sort" configuration digit = 6

* the values have been preset to match the order features.

Parameters *Pb 1* through *ySE* are disabled for the operator during self-tuning.

Limit Value Monitoring

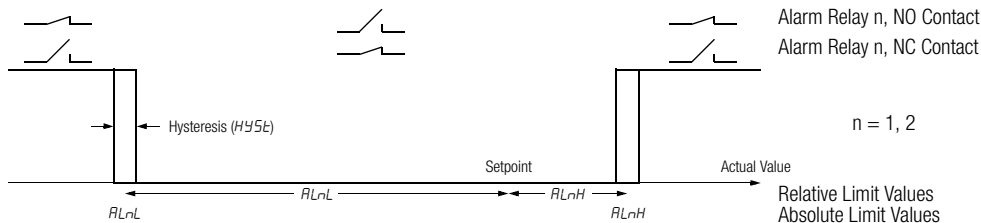

Actuation suppression: Alarm suppression remains inactive during actuation (configuration digit "alarms 1 and 2") until temperature has exceeded the lower limit value for the first time. During cooling, suppression is active until temperature has fallen below the upper limit value for the first time. Suppression is active when auxiliary power is activated, if the current setpoint is changed or setpoint 2 is activated, or if switching takes place from off to automatic operation.

Adjusting Control Performance – Manual Self-Tuning

Parameters $Pb\ I$, $Pb\ II$, t_U and t_C are determined by means of manual self-tuning in order to maintain optimized controller dynamics. An actuation test or an oscillation test is performed to this end.

Preparation

- **Complete configuration** (page 25) and **parameters configuration** (page 16) must first be entered for use of the controller.
- The actuators should be deactivated with the **off** function (page 15).
- A **recorder** must be connected to the sensor and adjusted appropriately to prevailing circuit dynamics and the setpoint.
- For 3-step controllers, on and off-time must be recorded for switching output I (e.g. with an additional recorder channel or a stopwatch).
- Configure as **limit transducer** (controller sort = 0) (see page 25).
- Set read-out cycle time to the minimum value: $t_C = 0.5$.
- Deactivate PWR limiting. $YH = 100$.
- Reduce (or increase) the **setpoint** so that overshooting and undershooting do not cause any impermissible values.

Performing the Actuation Test

- $dbnd = MRS$ Setting for 3-step controller (switching output II may not be triggered)
- $dbnd = 0$ Setting for step-action controllers (switching output II must be triggered)
- Start the recorder.
- Activate the actuators with **automatic operation**.
- Record two overshoots and two undershoots.

The actuation test is now complete for 2-step and step-action controllers.

Continue as follows for 3-step controllers:

- Set $dbnd$ to **0** in order to cause further overshooting with active switching output II. Record two overshoots and two undershoots.

Record **on-time** T_I and **off-time** T_{II} at switching output I or the continuous output for the last oscillation.

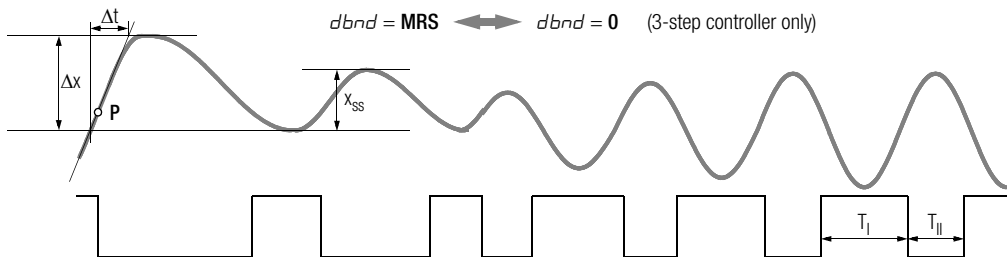

Evaluating the Actuation Test

- Apply a tangent to the curve at the intersection of the actual value and the setpoint, or at the cut-off point of the output.
- Measure time Δt .
- Measure oscillation amplitude x_{SS} , or overshooting for step-action controllers Δx .

Parameter	Parameter Values		
	2-step controller	3-step controller	Step-action controller
t_U	$1.5 \cdot \Delta t$		$\Delta t - (t_Y / 4)$
t_C	$t_U / 12$ ¹⁾		$t_Y / 100$
$Pb \ I$	$(x_{SS} / MRS) \cdot 100 \%$		$(\Delta x / MRS) \cdot 50 \%$
$Pb \ II$	—	$Pb \ I \cdot (T_I / T_{II})$	—

¹⁾ When controlling contactors, t_C should be adequately increased.

MRS = Measuring range span of the configured sensor type (compare Configuration, see page 25), not the measuring range according to C Designation

Performing the Oscillation Test

If an actuation test is not possible, for example if neighboring control loops influence the actual value too greatly, if switching output II must be active in order to maintain the actual value (cooling operating point), or if optimization is required directly to the setpoint for any given reason, control parameters can be determined by means of sustained oscillation. However, calculated values for t_U may be very inaccurate in this case under certain circumstances.

- Same preparation as for actuation test. The test can be performed without a recorder if the actual value is observed at the display, and if times are measured with a stopwatch.

- $dbnd = 0$ Setting for 3-step and step-action controllers
- Activate the actuators with **automatic operation**, and start the recorder if applicable. Record several oscillations until they become uniform in size.
- Measure **oscillation amplitude x_{ss}** .
- Record **on-time T_I** and **off-time T_{II}** at switching output I for the oscillations.

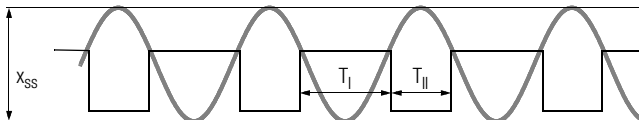

Evaluating the Oscillation Test

Parameter	Parameter Values		
	2-step controller	3-step controller	Step-action controller
t_U ¹⁾	$0.3 \cdot (T_I + T_{II})$		$0.2 \cdot (T_I + T_{II} - 2t_Y)$
t_C	$t_U / 12$ ²⁾		$t_Y / 100$
$Pb \ I$	$\frac{x_{ss} \cdot 100 \%}{MRS}$	$\frac{x_{ss} \cdot T_{II} \cdot 100 \%}{MRS (T_I + T_{II})}$	$\frac{x_{ss} \cdot 50 \%}{MRS}$
$Pb \ II$	—	$Pb \ I \cdot (T_I / T_{II})$	—

¹⁾ If either T_I or T_{II} is significantly greater than the other, value t_U is too large.

²⁾ When controlling contactors, t_C should be adequately increased.

Correction for step-action controllers in the event that T_I or T_{II} is smaller than t_Y :

Multiply $Pb \ I$ by $\frac{t_Y \cdot t_Y}{T_I \cdot T_I}$ if T_I is smaller, or by $\frac{t_Y \cdot t_Y}{T_{II} \cdot T_{II}}$ if T_{II} is smaller.

The value for t_U is very inaccurate in this case. It should be optimized in the closed loop control mode.

Closed Loop Control Mode

The closed loop control mode is started after self-tuning has been completed:

- Configure the desired control algorithm with **controller sort**.
- Adjust the **setpoint** to the required value.
- The dead band can be increased from $dbnd = 0$ for 3-step and step-action controllers if control of switching output I and II changes too rapidly, for example due to an unsteady actual value.

Self-Tuning

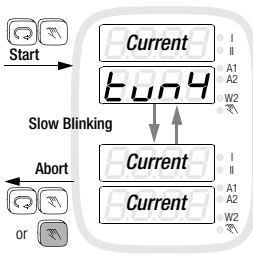

- $t_{un1} \dots t_{unB}$ blinks at the display at all operating levels during self-tuning.
- The controller is switched to the automatic operating mode after self-tuning has been successfully completed.
- In the case of 3-step controllers (controller sorts 4 and 5), cooling is activated if the upper limit value is exceeded in order to prevent overheating. Self-tuning then performs an oscillation test around the setpoint.

Sequence

- The setpoint which is active when tuning is started remains valid and can no longer be changed.
- Activation or deactivation of setpoint 2 does not become effective.
- Selected setpoint ramps are not taken into consideration.
- If started at the operating point (actual value approximates the setpoint value), overshooting cannot be avoided.

Abort

- Self-tuning can be aborted at any time with the keys (\rightarrow automatic operating mode), or by switching to manual / off with the key.
- If an error occurs during self-tuning, the controller no longer reads out an actuating signal. Self-tuning must be aborted in this case.

Additional information regarding error messages upon request.

Self-tuning is used to achieve optimized controller dynamics, i.e. parameters $P_b I$, $P_b II$ and t_U are determined.

Read-out cycle time t_C is not changed during self-tuning.

We recommend for t_C a value of $t_U/12$ to guarantee satisfactory controller dynamics. When controlling contactors, t_C should be adequately increased.

Preparation

- Complete configuration must be performed before self-tuning is started.
- The setpoint value is adjusted to the value which is required after self-tuning.

Start

- Briefly press the keys simultaneously at the operating level (automatic or off operating mode) in order to trigger self-tuning. Self-tuning cannot be started in the “actuator” or “limit transducer” mode.

Alarms

Blinking Display	Error Message Source	Blinking Display	Output	Comment
<i>Heating current</i>	Heating current monitoring	LED A1	Output A1 activated ¹⁾ or output II activated ²⁾	NO / NC contact defines in configuration digits "alarms 1 and 2" LED blinks at all levels
<i>Actual value</i>	Limit value monitoring 1	LED A1	Output A1 activated ¹⁾ or output II activated ²⁾	
<i>Actual value</i>	Limit value monitoring 2	LED A2	Output A2 activated ¹⁾	

¹⁾ only for R2100 G1

²⁾ only in the case of configuration as a 2-step controller

The display is switched to the operating level 30 seconds after value selection has been completed during configuration or parameter setting.

Error Messages

Responses in the event of an error:

1. In the case of R2100 G1 alarm output A1 is activated; output performance is determined by the "alarm 1" configuration digit (see Configuration on page 25).
In the case of other controllers and designations and in the case of configuration as a 2-step controller, read-out takes place at switching output II. LED II lights up when the relay contact II is closed and/or transistor output II is active.
2. LED A1 blinks at all levels. The (blinking) error message only appears at the operating level: in the event of faulty measured values at the display, at which the error-free measured value is otherwise displayed (*SEH*, *SEL* and *LEE*) while other error messages appear in the upper display.
3. The display is switched to the operating level 30 seconds after value selection has been completed during configuration or parameter setting.
4. Exceptions and additional information are included in the following table:

Display		Error Message Source	Response	Remedy	
<i>SE H</i>	sensor error high	Broken sensor or actual value greater than upper range limit	Ctr. Sort 2 or 3-step Step On/off ctr. Actuator	PWR Read-Out $yse = -100/0/100\%$ $yse \neq -100/0/100\%$ If the controller has settled in: last "plausible" PWR, if not: yse No response to error	Eliminate sensor error
<i>SE L</i>	sensor error low	Sensor polarity reversed or actual value less than lower range limit			
<i>CE</i>	current error	Current transformer has reversed polarity, is unsuitable or defective	Same as heating current monitoring alarm Continues to control temperature	Inspect current transformer	
<i>no t</i>	no tune	Self-tuning cannot be started (controller sort: "actuator" or "limit transducer")	No response to error Error message is shown until key is pressed	–	
<i>tE 2</i>	tune error 2	Disturbance in self-tuning sequence in steps 1 through 13 (step 2 in this case)	Control outputs I and II inactive Self-tuning must be aborted.	1)	
<i>LE</i>	loop error	Measured temperature rise is too small with heat on at 100%	Control outputs I and II inactive. Error message is not cleared until  key is pressed and held.	2)	
<i>PE</i>	parameter error	Parameter not within permissible limits	Control outputs I and II inactive. The parameter level is disabled.	3)	
<i>dE</i>	digital error	Error detected by digital component monitoring	Control outputs I and II inactive	Arrange for repair at authorized service center	
<i>AE</i>	analog error	Hardware error detected by analog component monitoring	Control outputs I and II inactive		

1) Avoid disturbances which impair the self-tuning sequence, e.g. sensor errors.

2) Close the control loop: Check the sensor, the actuators and the heater for correct functioning. Check sensor-heater assignments (wiring). Correctly optimize control parameters Ev and PB .

3) Restore default configuration and default parameters, and then reconfigure, or load user-defined default settings.

Setpoint Ramps

Function	Parameters SP_{up} and SP_{dn} cause a gradual temperature change (rising / falling) in degrees per minute.
Activation	<ul style="list-style-type: none">– When auxiliary power is switched on– When the current setpoint is changed– When setpoint 2 is activated– After switching from manual to automatic operation
Setpoint display	The targeted setpoint is displayed (not the currently valid setpoint) with a blinking r at the left-hand digit.
Limit values	Relative limit values make reference to the ramp, not the targeted setpoint. As a rule, no alarm is triggered for this reason.

Balancing

Thermocouple Correction (parameter: CR_L)

The correction value is selected in °C or °F. The displayed correction value is added to the measured temperature.

Cable Compensation for Pt 100 with 2-Wire Connection (parameter: CR_L)

The correction value can be determined automatically in the “Off” mode:

- Short circuit the sensor **at the measuring point**.
- Set the CR_L value to R_{ut0} .

Measured cable resistance is converted to temperature change and is entered as the CR_L value.

Balancing can also be performed manually if the sensor temperature is known:

$CR_L = \text{known sensor temperature} - \text{displayed temperature value}$

Scaling for Heating Current Monitoring (parameter: RH)

The default setting for the GTZ 4121 is 42.7 A. If the GTZ 4121 current transformer is not used for acquiring heating current, the current value must be selected at which the utilized transformer generates an output voltage of 10 V DC.

Configuration

(continued on following page)

Code	Controller sort
0	Limit transducer
1	Actuator
2	2-step controller, heat
3	2-step controller, cooling
4	3-step controller
5	3-step controller, water cooling
6	Step-action controller

Alarm 1					
Code		Actuation Suppression	Contact	Heating Circuit Monitoring	
0	relative	inactive	NO contact	inactive	
1	absolute				
2	relative	active			
3	absolute				
4	relative	inactive	NC contact		
5	absolute				
6	relative	active			
7	absolute				
8	relative	inactive		NO contact	active
9	absolute				
A	relative	active			
b	absolute				
c	relative	inactive	NC contact		
d	absolute				
E	relative	active			
F	absolute				

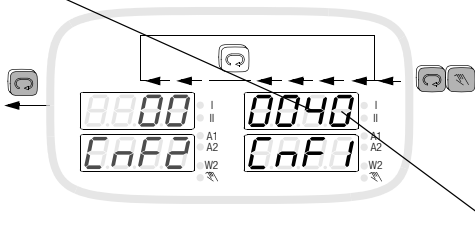

Configuration

(continued)

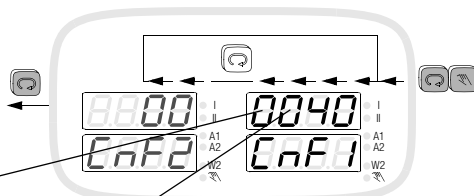

Code	Sensor Unit of Measure U/M ¹⁾
0	°C
1	°F
2	°C
3	°F
4	°C
5	°F
6	°C
7	°F
8	°C
9	°F
A	°C
b	°F
c	(no function)
d	 Saving and loading of device settings see page 28
e	
f	

Sensor Type				
Code	Type	Design	Measuring Range	Condition
0	J	Thermo- couple	-18 ... 850 °C	
1	L		-18 ... 850 °C	
2	K		-18 ... 1200 °C	
3	B		0 ... 1820 °C	
4	S		-18 ... 1770 °C	
5	R		-18 ... 1770 °C	
6	N		-18 ... 1300 °C	
7	1 ° Display	Pt 100		
8	0,1 ° Display			
0	0 ... 20 mA / 0 ... 10 V	Standard signal		for R2100 designation C30, C31
1	4 ... 20 mA			

¹⁾ Switching to and from °C / °F not effective for R2100 C30 and C31

Alarm 2				
Code		Actuation suppression	Contact	Binary input
0	relative	inactive	NO contact	Setpoint 2
1	absolute			
2	relative	active	NC contact	
3	absolute			
4	relative	inactive	NC contact	
5	absolute			
6	relative	active	NO contact	
7	absolute			
8	relative	inactive	NO contact	Manual / automatic or PWR out off-set
9	absolute			
A	relative	active	NC contact	
b	absolute			
C	relative	inactive	NC contact	
d	absolute			
E	relative	active	NO contact	
F	absolute			

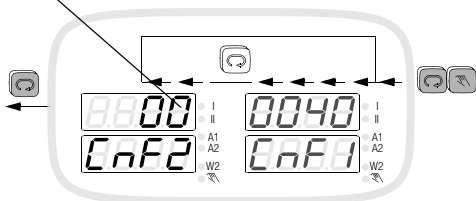

Saving and Loading Device Settings

Code	Function	 Comment
<i>d</i>	Current settings are saved as user-defined default settings. The settings which conform to the order features are overwritten in the process.	A configuration per customer specifications (K9) is stored here, and is overwritten in the process.
<i>E</i>	User-defined default settings are loaded. If settings have not already been saved with <i>d</i> in the past, the settings are loaded to match the order features.	All entries, including self-tuning and calibration results, are overwritten in the process.
<i>F</i>	Factory default settings are loaded. The settings do not conform to the order features.	

Controller Sorts

Parameters see page 16

Code	Controller Sort	Comment
<i>0</i>	Limit transducer	Switching output I is active where actual value < current setpoint, and switching output II is active where actual value > current setpoint + $dbnd$. Switching hysteresis is equal to $HYS\epsilon$. Switching status changes are possible once per ϵc .
<i>1</i>	Actuator	Read-out of a constant actuating signal to switching output I where $YS\epsilon > 0$, or switching output II where $YS\epsilon < 0$. The actuating cycle is equal to at least tc . No alarm functions.
<i>2</i>	2-step controller, "heat"	A harmonic-free PDPI control algorithm regulates switching output I in order to increase / decrease the actual value. The actuating cycle is equal to at least ϵc .
<i>3</i>	2-step controller, "cooling"	
<i>4</i>	3-step controller	A harmonic-free PDPI control algorithm regulates switching output I in order to increase the actual value, or switching output II in order to decrease the actual value. The actuating cycle is equal to ϵc . The dead band $dbnd$ suppresses switching back and forth between "heating" and "cooling" and no lasting deviation occurs.
<i>5</i>	3-step controller, water cooling	The PWR at switching output II is adapted to the non-linear performance characteristics of a water cooler. The actuating cycle is equal to ϵc .
<i>6</i>	Step-action controller	A harmonic-free PDPI control algorithm regulates switching output I or II in order to increase or decrease the actual value. The duration of the actuating impulse is equal to ϵc . The dead band $dbnd$ is symmetric to the setpoint.



Exchange of Setpoint with Binary Input

In the standard configuration, setpoint 2 ($SP2$) is activated with the binary input (see „Parameters Configuration“ page 16).

For this purpose, configuration digit „Alarm 2“ must be set to value 0 ... 7 (see. $LnF2$ page 27).

Manual Operation with Binary Input

Switching to manual operation is possible via the binary input.

- Bumpless switching to manual operation with **all** controller sorts
- The last PWR is “frozen” for step-action controllers as well.
- The last switching status is retained for limit transducers.
- Operation and display are identical to automatic operation, except that the  LED lights up and the PWR can be changed in the PWR display with the  and  keys.
- When configured as a step-action controller (controller sort set to 2 through 5), the $Y5t$ parameter **must** be set to 0.
- The “alarm 2” configuration digit must be set to a value of 8 ... F to this end (compare $LnF2$ on page 27)

PWR Out Offset with Binary Input

When configured as a step-action controller (controller sort set to 2 through 5), control quality can be significantly improved by means of PWR out offset where abrupt load fluctuations prevail.

- When the contact at the binary input is closed, the controller’s PWR is increased by an amount equaling $Y5t$.
- It is reduced by the same value when the contact is opened.
- No function during self-tuning
- Where $Y5t = 0$, the binary input activates manual operation (see above).
- The “alarm 2” configuration digit must be set to a value of 8 ... F to this end (see also $LnF2$ on page 27).

Example:

If a machine requires an average of 70% heating power during production operation, but only 10% during idle time, the difference of $Y5t$ is set to 60%, and the binary input is only activated during production.

Heating Current Monitoring

Function

Heating current is acquired with an external transformer (e.g. GTZ 4121). An alarm is triggered if the current setpoint is fallen short of by more than 20% with activated heat (control output I active), or if current is not “off” when the heat is switched off. The alarm is not triggered until heating current is high enough when output I is active, or when current drops to zero when output I is inactive. Monitoring is inactive if the controller is switched to *oFF*, as well as in the case of step-action controllers.

RNP5 current setpoint

Heater phase nominal current is entered for this parameter. *RNP5* can be set to *RuLo* for automatic adjustment with the heater switched on. The currently measured value is saved to memory.

Heating Circuit Monitoring

Function

- Can be set to active or inactive with the “Alarm 1” configuration digit (see “Configuration”).
- Without external transformer, without additional parameters
- Requires correct optimization of t_U and P_b / control parameters, i.e. heating circuit monitoring must be activated before self-tuning is started. In the event of manual optimization or subsequent adaptation of control parameters, the lower limit value for the t_U parameter must be observed:
$$\text{minimum } t_U = \frac{P_b}{50\%} \cdot \frac{MRS}{\Delta\theta / Dt}$$
$$\Delta\theta / Dt = \text{maximum temperature rise during actuation}$$
- Error message *LE* appears after approximately 2 times t_U , if heat remains on at 100% and measured temperature rise is too small.
- Monitoring is not active:
 - where controller sort = limit transducer, actuator or step-action controller during self-tuning
 - with standard signal input (R2100 C30, C31)
 - where PWR limiting $y_H < 20\%$

Technical Data

Annual mean relative humidity, no condensation	75%
Ambient temperature	
Nominal range of use	0 °C ... + 50 °C
Operating range	0 °C ... + 50 °C
Storage range	-25 °C ... + 70 °C

Aux. Voltage	Nominal Ranges of Use		Power Consumption
Nominal Value	Voltage	Frequency	
AC 110 V / AC 230 V	AC 95 V ... 253 V	48 Hz ... 62 Hz	Max. 10 VA typically 6 W

Relay Output	Floating, normally open contact
Switching capacity	AC/DC 250 V, 2 A, 500 VA / 50 W
Service life	> 2•10 ⁵ switching cycles at nominal load
Interference suppression	Utilize external RC element (100 Ω - 47 nF) at contactor

Transistor output suitable for commercially available semiconductor relays (SSR)		
Switching Status	Open-Circuit Voltage	Output Current
Active (load ≤ 800 Ω)	< DC 17 V	10 ... 15 mA
Inactive	< DC 17 V	< 0.02 mA
Overload limit	Short-circuit, continuous interruption	
Electrical Safety		
Safety class	II, panel-mount device, DIN EN 61010-1 section 6.50.4	
Fouling factor	1, per DIN EN 61010-1 section 3.7.3.1 and/or IEC 664	
Overvoltage category	II, per DIN EN 61010 appendix J and/or IEC 664	
Operating voltage	300 V per DIN EN 61010	
EMC requirements	IEC/EN 61326	

For complete technical data refer to the following data sheets:

Controller R2080: Order no. 3-349-216-03

Controller R2100: Order no. 3-349-217-03

Controller R2180: Order no. 3-349-218-03

Edited in Germany • Subject to change without notice • A pdf version is available on the internet.



GOSSEN METRAWATT

GMC-I Messtechnik GmbH
Südwestpark 15
90449 Nürnberg • Germany

Phone +49 911 8602-111
Fax +49 911 8602-777
E-Mail info@gossenmetrawatt.com
www.gossenmetrawatt.com