

SINEAX V 610 Temperature Transmitter

**Two-wire,
for Pt 100 inputs,
for rail mounting in housing K7**



Application

SINEAX V 610 is a two-wire transmitter. It is designed for **measuring temperature in combination with resistance thermometers Pt 100**. Thermocouple non-linearities are automatically compensated. The output signal is a current in the range 4...20 mA.

The sensor circuit is monitored for open and short-circuits and the output responds in a defined manner if one is detected.

The power supply (12...30 V DC) is connected together with the signal by the two leads connected to the measurement output (loop powered).

Fig. 1. Measuring transmitter SINEAX V 610 in housing K7 clipped onto a top-hat rail.

Features / Benefits

- Two-wire transmitter for installation in the process environment
- Open and short-circuit sensor circuit supervision / Defined output response should the supervision pick up
- Compact design (housing only 7 mm wide) / Makes maximum use of available space

- Standard circuit: **Three-wire connection**
- Input resistance: $R_i > 10 \text{ M}\Omega$
- Lead resistance: $\leq 30 \text{ }\Omega$ per lead
- Mains ripple suppression: For 50 Hz

Versions

Measured variables	Measuring ranges	Order No.
Temperatures with resistance thermometers for three-wire connection Pt 100, IEC 60 751	0 ... 100 °C	154 823
	0 ... 150 °C	154 831
	0 ... 200 °C	154 849
	- 30 ... + 70 °C	154 857
	- 50 ... + 150 °C	154 865

- Measuring output** \rightarrow (output/powering circuit)
- Output signal I_A : **Impressed DC current, linear with temperature**
- Standard range: 4...20 mA, 2-wire technique
- External resistance (burden): $R_{\text{ext max.}} = \frac{\text{Power supply [V]} - 12 \text{ V}}{\text{Max. output current [mA]}}$ [k Ω]

Technical Data

Measuring input \rightarrow

Temperature with resistance thermometers
Resistance types: Type Pt 100 (IEC 60 751)
Measuring current: $\leq 0,20 \text{ mA}$

Residual ripple in output current: $< 1\% \text{ p.p.}$
Response time: **Approx. 2 s**

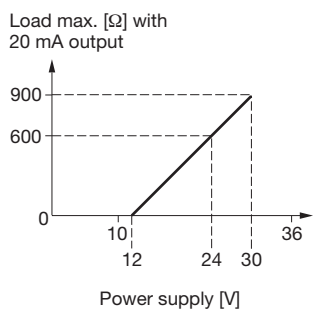

SINEAX V 610

Temperature Transmitter

Accuracy data (acc. to EN/IEC 60 770-1)

Reference value:	Measuring span
Basic accuracy:	Error limits $\leq \pm 0.2\%$ at reference conditions

Reference conditions

Ambient temperature	23 °C
Power supply	18 V DC
Output burden	250 Ω
Settings	Pt100, 3-wire, 0...600 °C

Additional errors (additive)

Low measuring ranges	
Resistance thermometer	± 0.3 K at measuring spans $< 400^\circ\text{C}$
High initial value	(Additional error = Factor · initial value)
Resistance thermometer	± 0.00075 K / °C
Influence of lead resistance at resistance thermometer	$\pm 0.01\%$ per Ω
Linearisation	$\pm 0.3\%$

Influencing factors

Temperature	$\leq \pm (0.15\% + 0.15 \text{ K})$ per 10 K with temperature measurement
Power supply influence (power supply on terminals)	$\leq \pm 0.005\%$ per V
Long-time drift	$\leq \pm 0.1\%$
Common and transverse mode influence	$\leq \pm 0.2\%$

Open and short-circuit sensor circuit supervision

Signalling modes:	Output signal with open or short-circuit rising to 21.6 mA
-------------------	--

Power supply

DC voltage:	Supply 12...30 V DC max. residual ripple 1% p.p. (supply must not fall below 12 V) Protected against wrong polarity
-------------	---

Installation data

Housing:	Housing K7 for rail mounting Dimensions see section "Dimensional drawings"
Material of housing:	Polyamide Flammability Class V2 acc. to UL 94, self-extinguishing, non-dripping, free of halogen

Mounting:

For snapping
– onto rail G
acc. to EN 50 035 – G32
or
– onto top-hat rail
acc. to EN 50 022 (35 × 15 mm
or 35 × 7.5 mm)

Standards

Electromagnetic compatibility: The standards EN 50 081-2 and EN 50 082-2 are observed

Protection (acc. to IEC 529 resp. EN 60 529):

Housing IP 40
Terminals IP 20

Electrical standards:

Acc. to IEC 1010 resp. EN 61 010

Ambient conditions

Climatic rating: IEC 60 068-2-1/2/3

Ambient temperature range:

– 25 to + 55 °C

Storage temperature range:

– 40 to + 80 °C

Annual mean

relative humidity:

$\leq 75\%$, no moisture condensation

Electrical connections

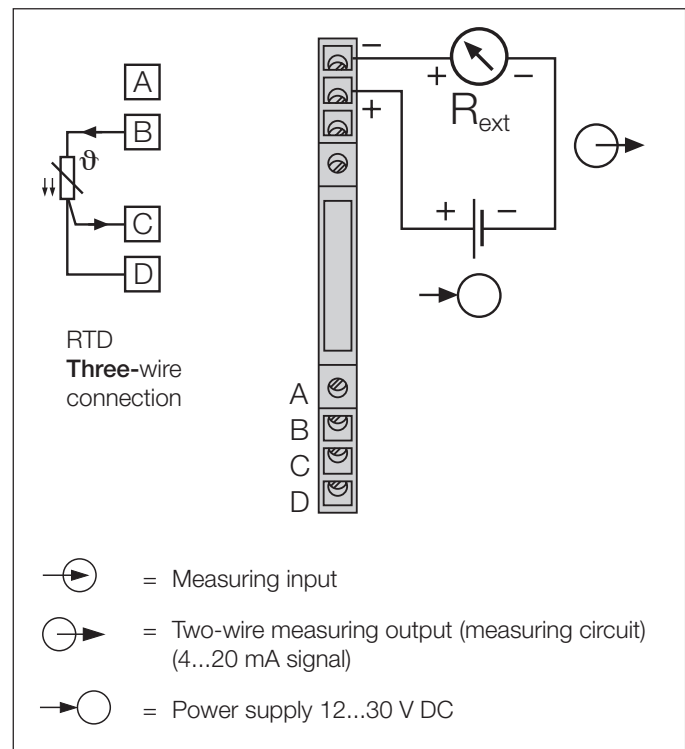

SINEAX V 610 Temperature Transmitter

Accessories and spare parts

Description	Order No.
Operating Instructions V 610 Bd in German	151 944
Operating Instructions V 610 Bf in French	151 960
Operating Instructions V 610 Be in English	151 952

Standard accessories

1 Operating Instructions, each in German, French and English

Dimensional drawings

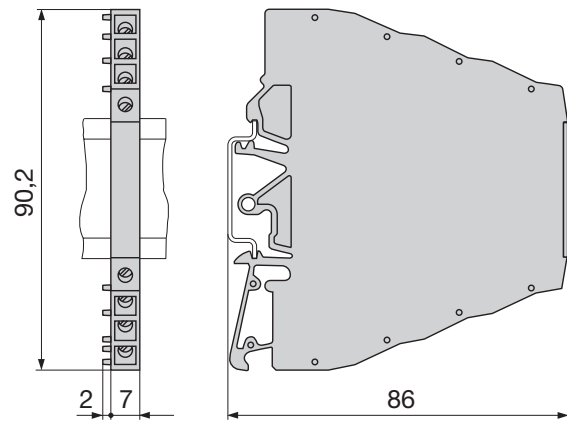

Fig. 2. SINEAX V 610 in housing **K7**
clipped onto a top-hat rail EN 50 022 – 35 x 7.5.

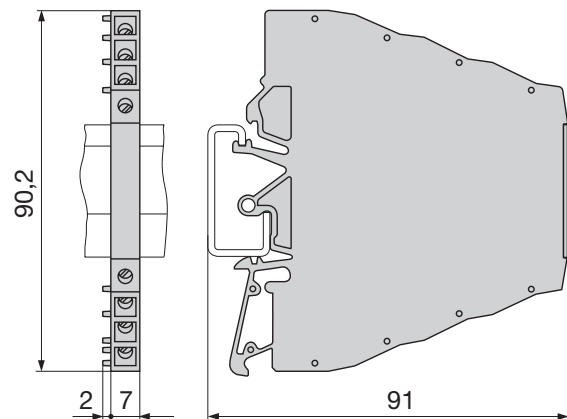

Fig. 3. SINEAX V 610 in housing **K7**
clipped onto a rail "G" EN 50 035 – G32.