

# SINEAX TV 808, 1 channel

## Isolating amplifier, output Ex or non-Ex

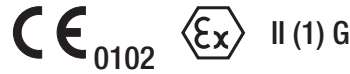

for electrically insulating, amplifying and converting DC signals, also designed for FSK<sup>1</sup>



### Application

The purpose of the isolating amplifier **SINEAX TV 808** (Fig. 1) is to electrically insulate input and output signals, respectively to amplify and/or change the signal level or type (current or voltage) of the input signals.

The instrument version SINEAX type 808-1164 1A has an **intrinsically safe output** and an **FSK continuity function** and is used to control smart I/P valve positioner in explosion hazard areas. The valve positioner adjust, for example, a pressure or the position of a valve in relation to the impressed output current (4...20 mA). The HART bypass permits bi-directional FSK signals to pass according to the HART protocol.

A green LED on the front side indicates device standing by.

The power supply and the inputs and outputs are electrically insulated.

The instrument fulfils all the important requirements and regulations concerning electromagnetic compatibility **EMC** and **Safety** (IEC 1010 resp. EN 61 010). It was developed and is manufactured and tested in strict accordance with the **quality assurance standard** ISO 9001.

### Variants

- (Ex) and non-Ex isolating amplifiers
- Designed or not designed for FSK communication
- User-specific input ranges
- Power supply 24...60 V DC/AC or 85...230 V DC/AC

### Features / Benefits

- Designed for FSK communication, hand-held terminal connected to separate terminals. This facilitates operation in conjunction with a smart I/P valve positioner designed for FSK and with a HART or user-specific protocol
- Electric insulation between input, output 2.3 kV and power supply (3.7 kV) / Prevents measurement errors due to potential leakage
- Burden voltage 20 V for non-Ex versions or 15 V for Ex instruments
- Non-standard user-specific ranges available
- AC/DC power supply / Universal
- Available in type of protection "Intrinsic safety" [Ex ia] IIC (see "Table 3: Data on explosion protection")



Fig. 1. Isolating amplifier SINEAX TV 808 in housing S17 clipped onto a top-hat rail.

### Technical data

#### Measuring input $\rightarrow$

DC current:	Standard range 4...20 mA Limit values 0...0.1 to 0...40 mA also live-zero, start value > 0 to $\leq$ 50% final value -0.1...0...+ 0.1 to -20...0...+ 20 mA max. span: $\leq$ 40 mA also bipolar asymmetrical $R_i = 15 \Omega$
DC voltage:	Limit values 0...0.06 to 0...40 also live-zero, start value > 0 to $\leq$ 50% final value -0.06...0...+ 0.06 to -20...0...+ 20 V, max. span: $\leq$ 40 V $R_i = 100 k\Omega$
Overload capacity:	DC current continuously 2-fold DC voltage continuously 2-fold

<sup>1</sup> FSK = Frequency Shift Keying

# SINEAX TV 808, 1 channel

## Isolating amplifier, output Ex or non-Ex

### Measuring output

DC current:	Standard ranges 4...20 mA, 0...20 mA 20...4 mA, 20...0 mA
Burden voltage:	Non-Ex version 20 V, Ex-version 15 V
External resistance:	Non-Ex version 1000 $\Omega$ , Ex-version 750 $\Omega$
Current limiter at $R_{ext}$ max.:	Approx. $1.1 \times I_{AN}$
Voltage limiter at $R_{ext} = \infty$ :	Approx. 26 V
Residual ripple in output current:	0.5% p.p.
Response time:	< 50 ms

### Power supply H

AC/DC power pack (DC and 45...400 Hz)

Table 3: Nominal voltages and tolerances

Nominal voltage $U_N$	Tolerance	Instrument version
24... 60 V DC / AC	DC -15...+ 33% AC $\pm$ 15%	Standard (Non-Ex)
85...230 V <sup>1</sup> DC / AC		
24... 60 V DC / AC	DC - 15...+ 33% AC $\pm$ 15%	Type of protection "Intrinsically safe" [EEx ia] IIC
85...230 V AC		
85...110 V DC	-15...+ 10%	

Power input:  $\leq 1.2$  W resp.  $\leq 3$  VA

### Accuracy data (acc. to DIN/IEC 770)

Basic accuracy: Limit error  $\leq \pm 0.2\%$   
Including linearity and reproducibility errors

### Reference conditions:

Ambient temperature	23 °C, $\pm 2$ K
Power supply	24 V DC $\pm 10\%$ and 230 V AC $\pm 10\%$
Output burden	Current: $0.5 \cdot R_{ext}$ max.

<sup>1</sup> For power supplies > 125 V, the auxiliary circuits should include an external fuse with a rating  $\leq 20$  A DC.

### Influencing factors:

Temperature	< $\pm 0.1\%$ per 10 K
Burden influence	< $\pm 0.1\%$
Longtime drift	< $\pm 0.3\%$ / 12 months
Switch-on drift	< $\pm 0.2\%$
Common and transverse mode influence	< $\pm 0.2\%$
Output + or - connected to ground	< $\pm 0.2\%$

### Installation data

Housing:	Housing S17 See section "Dimensional drawings" for dimensions
Material of housing:	Lexan 940 (polycarbonate) flammability class V-0 acc. to UL 94, self-extinguishing, non-dripping, free of halogen
Mounting:	For snapping onto top-hat rail (35 x 15 mm or 35 x 7.5 mm) acc. to EN 50 022 or directly onto a wall or panel using the pull-out screw hole brackets
Position of use:	Any
Terminals:	DIN/VDE 0609 Screw terminals with wire guards, for light PVC wiring and max. $2 \times 0.75$ mm <sup>2</sup> or $1 \times 2.5$ mm <sup>2</sup>
Permissible vibrations:	2 g acc. to EN 60 068-2-6
Shock:	3 x 50 g 3 shocks each in 6 directions acc. to EN 60 068-2-27
Weight:	Approx. 0.19 kg

### Electrical insulation:

All circuits (measuring input / measuring output / power supply) are electrically insulated

### Regulations

Electromagnetic compatibility:	The standards DIN EN 50 081-2 and DIN EN 50 082-2 are observed
Intrinsically safe:	Acc. to EN 50 020: 1994
Protection (acc. to IEC 529 resp. EN 60 529):	Housing IP 40 Connection IP 20
Electrical standards:	Acc. to IEC 1010 resp. EN 61 010
Operating voltages:	< 300 V between all insulated circuits

# SINEAX TV 808, 1 channel Isolating amplifier, output Ex or non-Ex

<p>Contamination level: 2</p> <p>Overvoltage category acc. to IEC 664: III for power supply II for measuring input and measuring output</p> <p>Double insulation: – Power supply versus all other circuits – Measuring input versus measuring output</p> <p>Test voltage: Measuring input versus: – measuring output 2.3 kV, 50 Hz, 1 min. – power supply 3.7 kV, 50 Hz, 1 min. Measuring output versus: – power supply 3.7 kV, 50 Hz, 1 min.</p>	<p><b>Environmental conditions</b></p> <p>Climatic rating: Climate class 3Z acc. to VDI/VDE 3540</p> <p>Commissioning temperature: – 10 to + 55 °C</p> <p>Operating temperature: – 25 to + 55 °C, <b>Ex – 20</b> to +55 °C</p> <p>Storage temperature: – 40 to + 70 °C</p> <p>Annual mean relative humidity: ≤ 75%</p>
---	--

**Table 2: Ordering Informations**

DESCRIPTION	MARKING												
<p><b>1. Mechanical design</b> Housing S17 for rail and wall mounting</p>	808 - 1												
<p><b>2. Number of channels</b> 1) 1 channel</p>	1												
<p><b>3. Version / Power supply</b></p> <table border="0" style="width: 100%;"> <tr> <td style="width: 60%;">5) [EEx ia] IIC, (output intrinsically safe)</td> <td style="width: 30%;">24 ... 60 V DC/AC</td> <td style="width: 10%; text-align: center;">5</td> </tr> <tr> <td>6) [EEx ia] IIC, (output intrinsically safe)</td> <td>85 ... 110 V DC / 230 V AC</td> <td style="text-align: center;">6</td> </tr> <tr> <td>7) Standard,</td> <td>24 ... 60 V DC/AC</td> <td style="text-align: center;">7</td> </tr> <tr> <td>8) Standard,</td> <td>85 ... 230 V DC/AC</td> <td style="text-align: center;">8</td> </tr> </table>	5) [EEx ia] IIC, (output intrinsically safe)	24 ... 60 V DC/AC	5	6) [EEx ia] IIC, (output intrinsically safe)	85 ... 110 V DC / 230 V AC	6	7) Standard,	24 ... 60 V DC/AC	7	8) Standard,	85 ... 230 V DC/AC	8	
5) [EEx ia] IIC, (output intrinsically safe)	24 ... 60 V DC/AC	5											
6) [EEx ia] IIC, (output intrinsically safe)	85 ... 110 V DC / 230 V AC	6											
7) Standard,	24 ... 60 V DC/AC	7											
8) Standard,	85 ... 230 V DC/AC	8											
<p><b>4. Function</b></p> <p>1) 1 input, 1 electrically insulated output</p> <p>4) 1 input, 1 electrically insulated output, designed for FSK communication (HART) (Condition: Input and output 4...20 mA)</p>	1 4												
<p><b>5. Input signal</b></p> <p>1) 4 ... 20 mA</p> <p>9) Input [V] <input style="width: 100px; height: 15px;" type="text"/></p> <p>Z) Input [mA] <input style="width: 100px; height: 15px;" type="text"/></p> <p>Line 9: [V] 0 ... 0.06 to 0 ... 40 also live-zero, start value &gt; 0 to ≤ 50% final value [V] –0.06 ... 0 ... + 0.06 to –20 ... 0 ... + 20, max. span: ≤ 40 V also bipolar asymmetrical</p> <p>Line Z: [mA] 0 ... 0.1 to 0 ... 40 also live-zero, start value &gt; 0 to ≤ 50% final value [mA] –0.1 ... 0 ... + 0.1 to –20 ... 0 ... + 20 max. span: ≤ 40 mA also bipolar asymmetrical</p>	1 9 Z												

Continuation of Table 4 see on next page!

# SINEAX TV 808, 1 channel

## Isolating amplifier, output Ex or non-Ex

DESCRIPTION	MARKING
<b>6. Output signal</b> A) 4 ... 20 mA B) 0 ... 20 mA C) 20 ... 4 mA D) 20 ... 0 mA With FSK communication (HART) only possible with 4 ... 20 mA	A B C D

Possible special versions, e.g. increased climatic rating on inquiry.

**Table 3: Data on explosion protection**  **II (1) G**

Order Code	Type of protection	Output	Input/ Power supply	Type Examination Certificate	Mounting location									
808-1... ..	[EEx ia] IIC	$U_o = 27.3 \text{ V}$ $I_o = 99 \text{ mA}$ $P_o = 675 \text{ mW}$ <table border="1" style="margin-left: auto; margin-right: auto;"> <thead> <tr> <th></th> <th>IIC</th> <th>IIB</th> </tr> </thead> <tbody> <tr> <td><math>L_o</math></td> <td>4.1 mH</td> <td>15 mH</td> </tr> <tr> <td><math>C_o</math></td> <td>82 nF</td> <td>677 nF</td> </tr> </tbody> </table>		IIC	IIB	$L_o$	4.1 mH	15 mH	$C_o$	82 nF	677 nF	$U_m = 253 \text{ V AC}$ resp. $125 \text{ V DC}$	PTB 98 ATEX 2060	<b>Outside</b> the hazardous area
	IIC	IIB												
$L_o$	4.1 mH	15 mH												
$C_o$	82 nF	677 nF												

### Compatibility

Most of the usual smart valve positioners (current-to-pneumatic converters) on the market with IS approval are compatible with the intrinsically safe output of the TV 808 (see Table 4). On inquiry, we will verify if other valve positioners can be used.

Table 4:

Manufacturer	Type	Ex designation	$U_i$ [V]	$I_i$ [mA]	$P_i$ [mW]	$L_i$ [mH]	$C_i$ [nF]	Burden voltage [V] Burden [ $\Omega$ ]
Neles Jamesbury	<b>ND820</b>	EEx ia IIC T5, T6 Demko 96D. 120954	30	100	—	0	0	12.6 V 630 $\Omega$
Elsag Bailey- H & B	<b>TZID</b>	EEx ia IIC T4, T5, T6 PTB Nr. -94.C.2133 X	30	150	1100	0.05	1.2	10.8 V 540 $\Omega$
Samson	<b>3780</b>	EEx ia IIC T6 PTB Nr. Ex-94.C.4069	28	115	1000	0	5.3	10.8 V 540 $\Omega$
Foxboro Eckhart	<b>SRD991</b>	EEx ia IIC (T6)	30	130	900	0	1.4	12.0 V 600 $\Omega$
Fisher Controls	<b>Fieldvue DVC 5000</b>	EEx ia IIC T5 LCIE 95.D6115	30	227	1700	0	0	12.0 V 600 $\Omega$
Siemens	<b>SIPART PS</b>	EEx ib IIC T4, T5, T6 PTB Nr. Ex-91, C, 2138 Zone 1	30	100	1000	1	6	11.0 V 550 $\Omega$

# SINEAX TV 808, 1 channel Isolating amplifier, output Ex or non-Ex

## Electrical connections

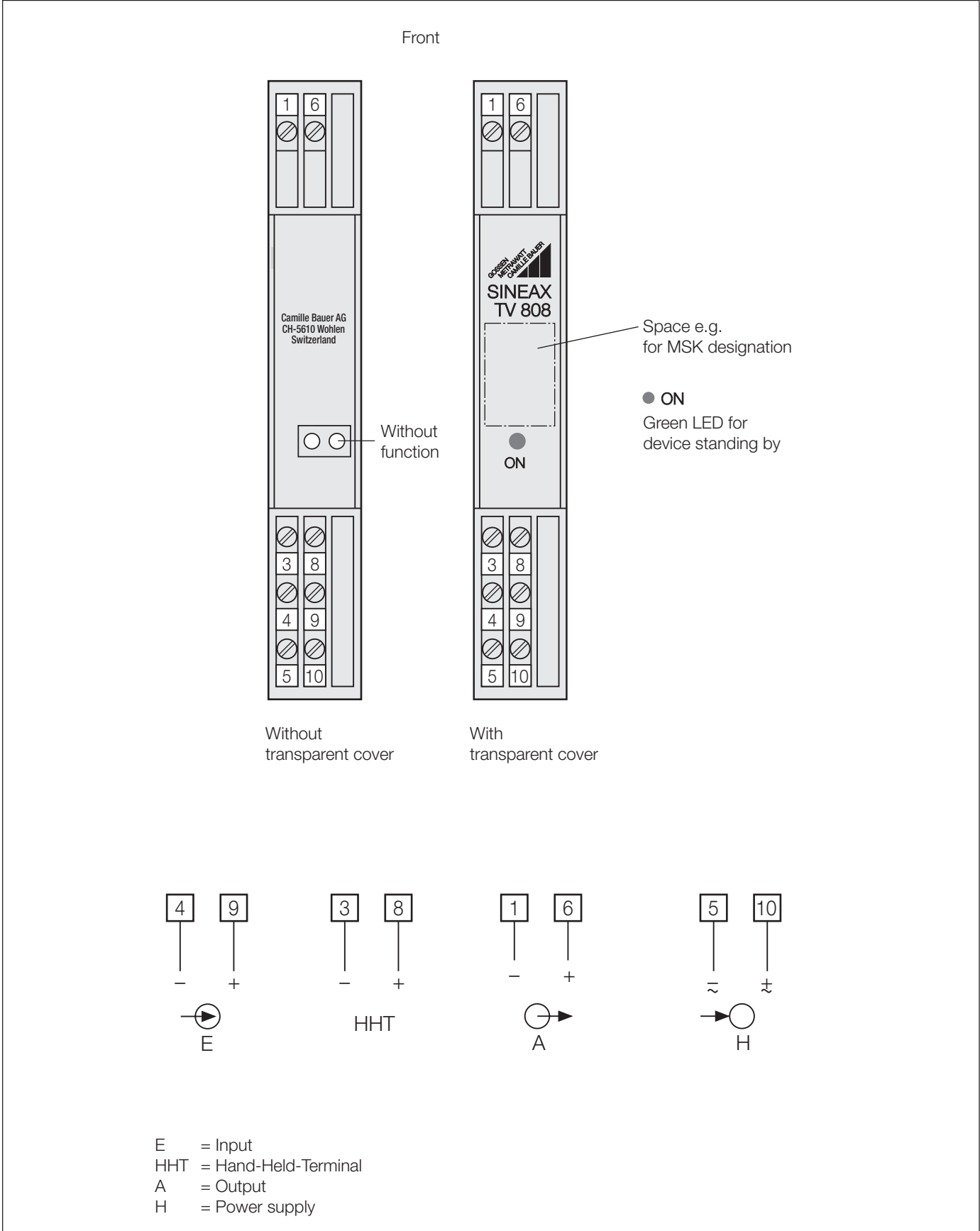

# SINEAX TV 808, 1 channel

## Isolating amplifier, output Ex or non-Ex

Table 5: Terminal allocation

Instruments version	Wiring diagram / Terminal allocation
<p>Types 808-1154 1A or 808-1164 1A</p> <p>input non-Ex, <b>output intrinsically safe,</b> burden voltage <b>15 V</b>, <b>designed for FSK</b></p> <p>Fig. 2</p>	
<p>Types 808-117... or 808-118...</p> <p>input and output non-Ex, burden voltage <b>20 V</b>, FSK (option)</p> <p>Fig. 3</p>	

<sup>1</sup>HHT = Hand-Held-Terminal

# SINEAX TV 808, 1 channel Isolating amplifier, output Ex or non-Ex

## Dimensional drawings

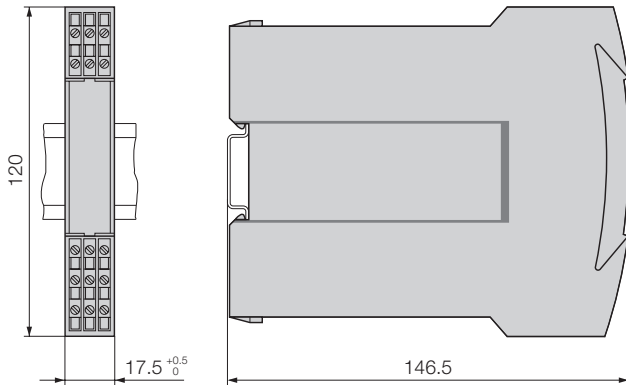

Fig. 4. SINEAX TV 808 in housing **S17** clipped onto a top-hat rail (35 x 15 mm or 35 x 7.5 mm, acc. to EN 50 022).

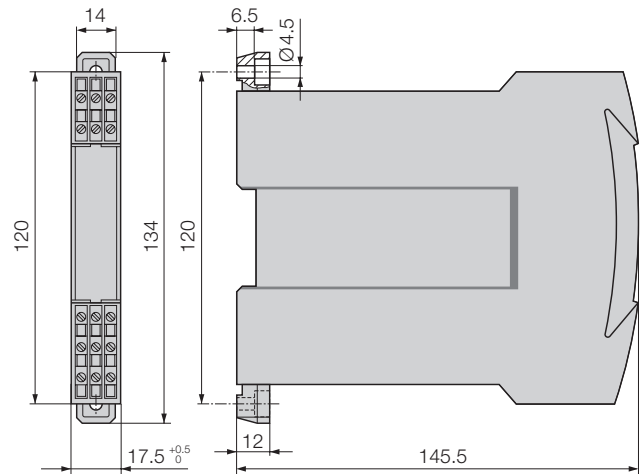

Fig. 5. SINEAX TV 808 in housing **S17**, screw hole mounting brackets pulled out.

## Standard accessories

- 1 Operating Instructions in three languages: German, French, English
- 2 Labels (under transparent cover)
- 1 Type Examination Certificate (for instruments in type of protection "Intrinsically safe" only)