

Safety precautions to be strictly observed are marked with following symbols in the Operating Instructions:



The instruments must only be disposed of in the correct way!

Operating Instructions

Programmable Transmitter for angular position KINAX 2W2



Camille Bauer LTD
Aargauerstrasse 7
CH-5610 Wohlen/Switzerland
Phone +41 56 618 21 11
Fax +41 56 618 35 35
e-mail: info@camillebauer.com
http://www.camillebauer.com



2W2 Be 149 973-02 09.09

Contents

1. Read first and then ... 1
2. Brief description..... 1
3. Scope of supply 1
4. Specification and ordering information..... 1
5. Technical data 2
6. Mounting and commissioning..... 2
7. Dimensional drawings..... 3
8. Declaration of conformity..... 4

1. Read first and then ...



The proper and safe operation of the device assumes that the Operating Instructions are **read carefully** and the safety warnings given in the various Section

6. Mounting and commissioning are **observed**.

Unauthorized repair or alteration of the unit invalidates the warranty!

The device should only be handled by appropriate trained personnel who are familiar with it and authorised to work in control technique installations.

2. Brief description

The KINAX 2W2 converts the angular position of a shaft into a **load independent** direct current signal, proportional to the angular position. The unit is contact free and has minimal mechanical abrasion on the input shaft. It technically extends the delivery program of angular transmitters with a programmable version and thus creates a number of new technical application possibilities.

Explosion-proof "Intrinsically safe EEx ia IIC T6" version with I.S. measuring output rounds off this series of transmitters.

3. Scope of supply

Transmitter, one of the six versions (Fig. 1)

3 clamps (Fig. 2)

1 ea. Operating Instructions (Fig. 3) in English, French, German

1 Type Examination Certificate (Fig. 3), only for Ex version devices

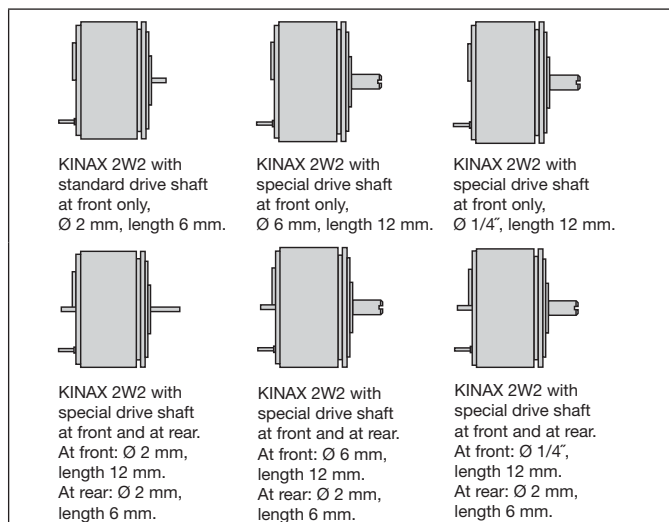

Fig. 1

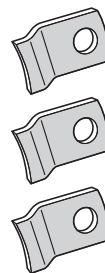

Fig. 2

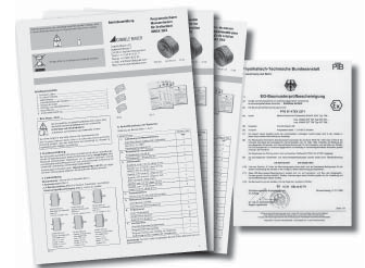

Fig. 3

4. Specification and ordering information

Significance of the digits 1. to 7.

Description	Order Code
1. Version of the transmitter	760-
Standard, measuring output non intrinsically safe	1
EEx ia IIC T6, ATEX	2
Measuring output intrinsically safe	
2. Mechanical angle range	
Angle range, to 50 α°	1
Angle range > 50 to 350 α°	2
3. Drive shaft	
Standard, dia. 2 mm at front, length 6 mm	1
Special, dia. 2 mm at front, length 12 mm, dia. 2 mm at rear, length 6 mm	2
Special, dia. 6 mm at front, length 12 mm	3
Special, dia. 6 mm at front, length 12 mm, dia. 2 mm at rear, length 6 mm	4
Special, dia. 1/4" at front, length 12 mm	5
Special, dia. 1/4" at front, length 12 mm, dia. 2 mm at rear, length 6 mm	6
4. Output variable	
Current, 4 to 20 mA, 2-wire connection	1
5. Electrical connection	
Connection to soldering terminals	1
Connection to screw terminals	2
6. Test certificate	
Without test certificate	0
Test certificate in German	D
Test certificate in English	E
7. Configuration	
Basic configuration, programmed	0
Programmed to order	1
Programmed to order, with zero position mark on the drive shaft disk	2

Note: The remaining order code digits concern special features.

5. Technical data

Measuring input \ominus

Measuring range of rotation angle: Programmable between 0 to 10 and 0 to 50 or 0 to 50 and 0 to 350°

Measuring output \odot

Power supply: H = 12 to 33 V DC (possible with standard version, non-Ex)
H = 12 to 30 V DC (necessary with Ex version, type of protection "Intrinsically safe EEx ia IIC T6")

Max. residual ripple: < 0.3% p.p.

Output variable I_A : Load-independent DC current 4 to 20 mA, proportional to the input angle

External resistance (load): $R_{\text{ext max.}} [\text{k}\Omega] = \frac{H [\text{V}] - 12 \text{ V}}{I_A [\text{mA}]}$
H¹ = DC power supply
I_A = Output signal end value

Accuracy data

Reference value: Measuring span

Basic accuracy: Error limits ≤ 0.5% with linear characteristic

Material

Housing (main part): Metal (aluminium)
Surface chromated

Mechanical withstand

Permissible vibrations: 5 g every 2 h in 3 directions
f ≤ 200 Hz

Shock: 3 × 50 g
10 shocks each in 3 directions

Admissible static loading of shaft:

Sense	Drive shafts dia.	
	2 mm	6 mm resp. 1/4"
radial max.	16 N	83 N
axial max.	25 N	130 N

Mounting position: Any

Regulations

Test voltage: 500 V_{eff}, 50 Hz, 1 min.
all electrical connections against housing

Housing protection: IP 50 acc. to IEC 529

Environmental conditions

Climatic rating: **Standard version**
Temperature -25 to +75 °C
Annual mean relative humidity ≤ 90%
or
Version with improved climatic rating
Temperature -40 to +75 °C
Annual mean relative humidity ≤ 95%
Ex version
see enclosed Ex-type-examination Certificate

Transportation and storage temperature: -40 to 80 °C

Altitude: 2000 m max.

Indoor use statement!

6. Mounting and commissioning

Mechanical mounting

All versions of the transmitter can be mounted either directly or by means of 3 mounting clips to the item being measured. Both methods of mounting and the relevant drilling and cut-out plans can be seen from Table 1:

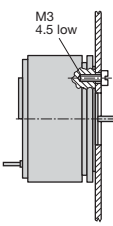
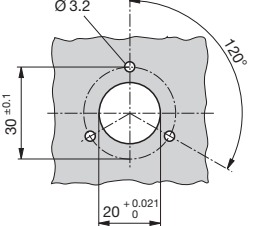
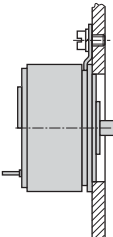
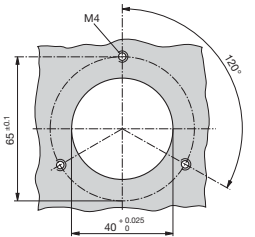
	Mounting versions ²	Drilling and cut-out diagrams for mounting transmitters
directly		
with 3 clamps		

Mounting/positioning

Three **M3** screws are needed for the "directly" mounted versions and three **M4** screws for those "with clamps". The screws are not supplied, because the required length varies according to the thickness of the mounting surface.



When deciding where to install the transmitter (measuring location), take care that the "Ambient conditions" given in Section "5. Technical data" are **not exceeded**.

Angular position transmitters of the KINAX 2W2 range do not require a mechanical zero position mark (however, this is made if required by the customer). After mounting, the transmitter can be moved to any position and configured using the 2W2 software. A power supply connection to the KINAX 2W2 is not required in order to use the 2W2 configuration software (Fig. 4; AUX switch on the PK 610 in the ON position).



The angular position transmitter must only be programmed outside of the Ex area!

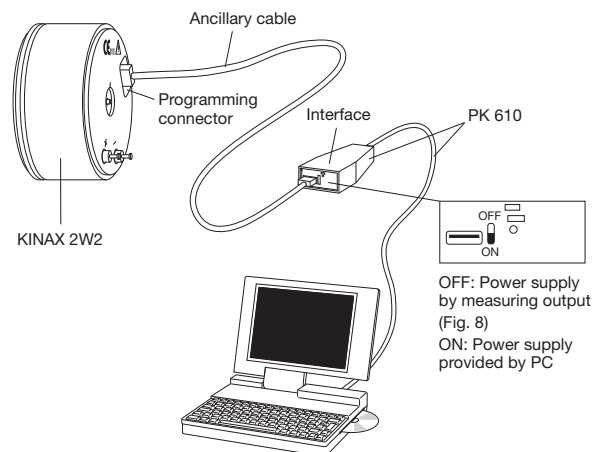

Fig. 4

Positioning procedure for the KINAX 2W2

1. Mount the angular position transmitter and mechanically connect it to the object to be measured. Connect the KINAX 2W2 to the programming device according to Fig. 4. Start the 2W2 configuration software. If necessary, configure the device with the required measuring range data.
2. Place the measuring device in a defined position (preferably the zero position).
3. Select the "Adjustment" menu item under "SERVICE" in the configuration software. In the "Mechanical position" window enter the current angle of the measuring device and then select "Adjust". The measuring device is now configured for the defined angle.

¹ Polarity reversal protection. The voltage must not fall below 12 V.

² For the example of KINAX 2W2 with standard drive shaft at front only, dia. 2 mm, length 6 mm.

Electrical connections

For connecting the external wires, the transmitter has 2 soldering pins at the back (Fig. 5) or a connecting print with screw terminals (Fig. 6). The soldering posts suffice Protection Class IP 00 acc. to IEC 529.

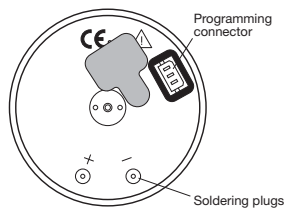

Fig. 5

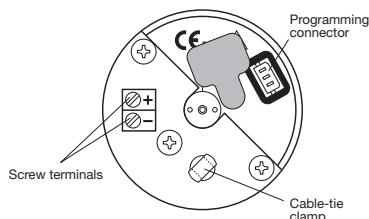

Fig. 6



Note that, ...

... the data required to carry out the prescribed measurement must correspond to those marked on the nameplate of the KINAX 2W2 (Range, Output, Supply Voltage)!

... the total loop resistance connected to the output (receiver plus leads) **does not** exceed the maximum permissible value R_{ext} ! See **"Measuring output"** in Section "5. Technical data" for the maximum values of R_{ext} !

... twisted cores must be used for the measured variable input and output leads and routed as far away as possible from power cables!

In all other respects, observe all local regulations when selecting the type of electrical cable and installing them!



In the case of **"Intrinsically safe"** explosion-proof versions [EEx ia] IIC, the supplementary information given on the EC-Type-Examination Certificate, the EN 60 079-14 and also local regulations applicable to electrical installations in explosion hazard areas must be taken into account!



KINAX 2W2	Supply Voltage	Range: 0...350°	linear	Camille Bauer AG Aargauerstr. 7 CH-5610 Wohlen Switzerland
Type: 760 - 1211 1D0	12...33V DC	Output: 2-Wire 4...20 mA		
Ord: 000/041678/010/001		Rotation Sense:		

Fig. 7. Example of a nameplate.



Do not **excessively heat** the soldering posts (3)!
Solder using a **small pencil bit** soldering iron!

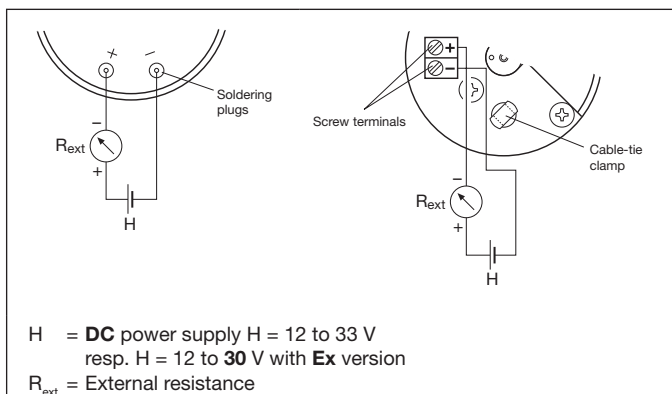

Fig. 8. Connection diagrams for 2-wire connection.

Fine adjustment

The analog output can be finely adjusted using the 2W2 configuration software. Select the menu item **"Adjustment"** under **"SERVICE"**. In the **"Analog output"** window, the zero position and the end value can now be adjusted.

Procedure:

1. Put the transmitter into operation and connect the programming device according to Fig. 4 (AUX switch on the PK 610 in the OFF position).
2. Place the measuring device in the zero position, i.e. in the position in which the KINAX 2W2 should output 4 mA. Adjust with the **"ZERO"** virtual knob until the output is correct.
3. Place the measuring object in the end position, i.e. in the position, in which the KINAX 2W2 should output 20 mA. Adjust with the virtual knob **"Span"** until the output signal is correct.
4. Close the adjustment with the **"Done"** button.

The adjusting range of the zero position and span is 5%. If this range is not sufficient, the span can be adapted by changing the mechanical characteristics (increase/decrease the measuring span).

Simulation mode

The 2W2 configuration software supports the operation of the KINAX 2W2 in simulation mode. The simulation of the measured value allows the subsequent chain of devices to be tested during the installation phase.

Procedure:

1. Select the **"Simulation"** menu item under **"Service"** in the configuration software.
2. The window displays the device configuration. After the entry of the required angle, the analog output is set in accordance with the device configuration.

7. Dimensional drawings

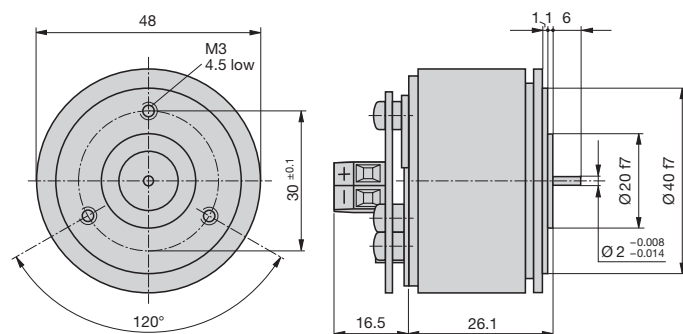

Fig. 9. KINAX 2W2 with standard drive shaft at front only, dia. 2 mm, length 6 mm, screw terminal version.

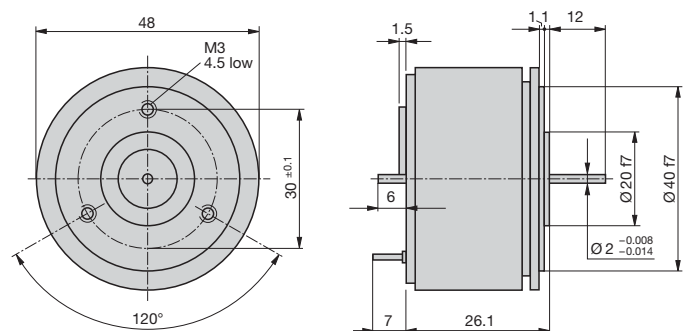

Fig. 10. KINAX 2W2 with special drive shaft at front and rear. At front: dia. 2 mm, length 12 mm. At rear: dia. 2 mm, length 6 mm.

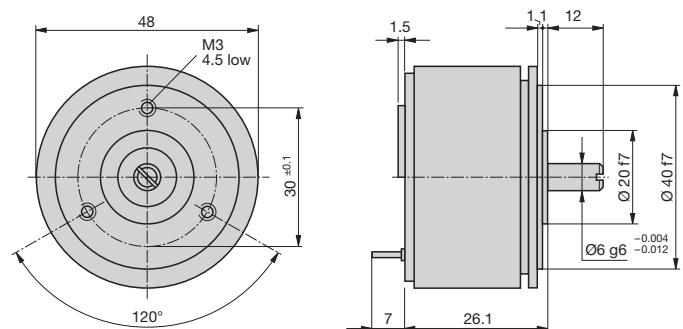

Fig. 11. KINAX 2W2 with special drive shaft at front only, dia. 6 mm, length 12 mm.

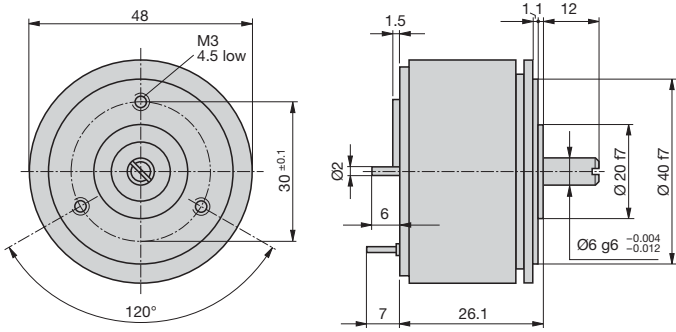

Fig. 12. KINAX 2W2 with special drive shaft at front **and** at rear.
At front: dia. 6 mm, length 12 mm. At rear: dia. 2 mm, length 6 mm.

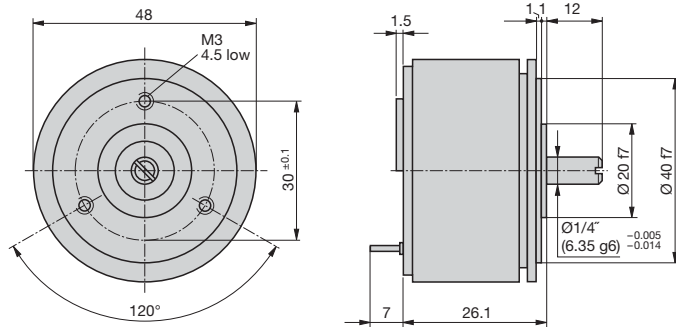

Fig. 13. KINAX 2W2 with special drive shaft at front **only**,
dia. 1/4", length 12 mm.

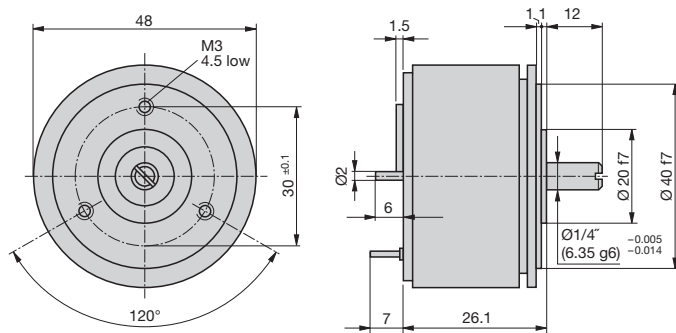

Fig. 14. KINAX 2W2 with special drive shaft at front **and** at rear.
At front: dia. 1/4", length 12 mm. At rear: dia. 2 mm, length 6 mm.

8. Declaration of conformity



EG - KONFORMITÄTSERKLÄRUNG
EC DECLARATION OF CONFORMITY



Dokument-Nr. /
Document No.: 2W2.DOC

Hersteller /
Manufacturer: Camille Bauer AG
Switzerland

Anschrift /
Address: Aargauerstrasse 7
CH-5610 Wohlen

Produktbezeichnung /
Product name: Programmierbar Messumformer für Drehwinkel
Programmable Transmitter for angular position

Typ / Type: Kinax WT 2W2

Das bezeichnete Produkt stimmt mit den Vorschriften folgender Europäischer Richtlinien überein, nachgewiesen durch die Einhaltung folgender Normen:

The above mentioned product has been manufactured according to the regulations of the following European directives proven through compliance with the following standards:

Nr. / No.	Richtlinie / Directive
2004/108/EG	Elektromagnetische Verträglichkeit - EMV-Richtlinie
2004/108/EC	Electromagnetic compatibility - EMC directive

EMV / EMC	Fachgrundnorm / Generic Standard	Messverfahren / Measurement methods
Störaussendung / Emission	EN 61000-6-4 : 2007	EN 55011 : 2007+A2:2007
Störfestigkeit / Immunity	EN 61000-6-2 : 2005	IEC 61000-4-2: 1995+A1:1998+A2:2001 IEC 61000-4-3: 2006+A1:2007 IEC 61000-4-4: 2004 IEC 61000-4-6: 2008

Nr. / No.	Richtlinie / Directive
2006/95/EG	Elektrische Betriebsmittel zur Verwendung innerhalb bestimmter Spannungsgrenzen - Niederspannungsrichtlinie - CE-Kennzeichnung : 95
2006/95/EC	Electrical equipment for use within certain voltage limits - Low Voltage Directive - Attachment of CE marking : 95

EN/Norm/Standard	IEC/Norm/Standard
EN 61010-1: 2001	IEC 61010-1: 2001

Ort, Datum /
Place, date:

Wohlen, 12. August 2009

Unterschrift / signature:]

M. Ulrich

M. Ulrich
Leiter Technik / Head of engineering

J. Brem

J. Brem
Qualitätsmanager / Quality manager