

# SINEAX I 552

## Transducer for AC current

With power supply  
 RMS value measurement, with 2 measuring ranges  
 Carrying rail housing P13/70



Fig. 1. Transducer SINEAX I 552 in housing P13/70 clipped onto a top-hat rail.

### Application

The transducer **SINEAX I 552** (Fig. 1) converts a sinusoidal or a distorted AC current into a **load independent** DC current or a **load independent** DC voltage proportional to the measured value.

The transducer fulfils all the important requirements and regulations concerning electromagnetic compatibility **EMC** and **Safety** (IEC 1010 resp. EN 61 010). It was developed and is manufactured and tested in strict accordance with the **quality assurance standard** ISO 9001.

### Features / Benefits

- **Measuring input: AC current, sine or distorted wave forms, RMS value measurement**

Measured variable	Measuring range limits
AC current	0...0.1 / 0.5 to 0...≤ 1.2 / 6 A

- **Measuring output: Unipolar or live zero output variables**
- **Measuring principle: Logarithmic method**
- **AC/DC power supply / Universal**
- **Standard version as per Germanischer Lloyd**

### Mode of operation

Input signal I~ is galvanically separated from the mains network using a transformer.

The following mathematical expression is then formed using a root-mean-square value computer

$$I_{\text{eff}} = \sqrt{\frac{1}{T} \int_0^T i^2 dt}$$

Following filtration by means of an active filter, the transformation properties of the measuring transducer are determined in the succeeding characteristics circuit.

The output amplifier transforms the measuring signal into an impressed DC current output signal A.

The electronic components are supplied with voltage H from the mains supply unit.

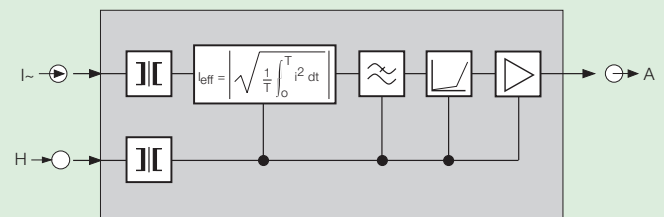

Fig. 2. Block diagram.

### Technical data

#### General

Measured quantity:	AC current Sine or distorted wave forms RMS value measurement
Measuring principle:	Logarithmic method

# SINEAX I 552

## Transducer for AC current

### Measuring input E $\rightarrow$

Nominal frequency  $f_N$ : 50/60 or 400 Hz

Nominal input current  $I_N$   
(measuring range end value): Measuring range limit values  
0...0.1 / 0.5 to 0...< 1.2 / 6 A  
Measuring range end value ratio  
1 : 5

Setting: Admissible alteration of full scale output, variable sensitivity, adjustable with potentiometer  
Setting range  
0.85...1.15 ·  $I_N$  ( $\pm 15\%$ )

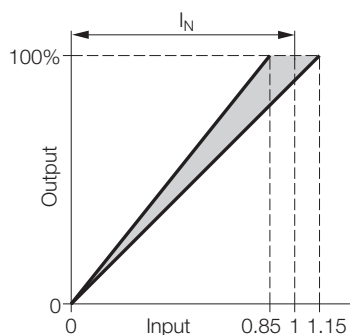

Own consumption:  $\leq 1$  VA with input end value

Overload capacity:

Measured quantity $I_N$	Number of applications	Duration of one application	Interval between two successive applications
$1.2 \cdot I_N$	—	continuously	—
$20 \cdot I_N$	10	1 s	100 s

### Measuring output A $\rightarrow$

Load-independent DC current: 0...1 to 0...20 mA  
resp. live-zero  
0.2...1 to 4...20 mA

Burden voltage: 15 V

External resistance:  $R_{\text{ext max.}} [\text{k}\Omega] = \frac{15 \text{ V}}{I_{\text{AN}} [\text{mA}]}$   
 $I_{\text{AN}}$  = Output current end value

Load-independent DC voltage: 0...1 to 0...10 V  
resp. live-zero  
0.2...1 to 2...10 V

External resistance:  $R_{\text{ext}} [\text{k}\Omega] \geq \frac{U_A [\text{V}]}{2 \text{ mA}}$

Current limit under overload:  $\leq 1.5 \cdot I_{\text{AN}}$  at current output  
Approx. 10 mA at voltage output

Voltage limit under  $R_{\text{ext}} = \infty$ :  $\leq 25$  V

Residual ripple in output current:  $\leq 0.5\%$  p.p. at setting time 300 ms  
 $\leq 2\%$  p.p. at setting time 50 ms

Setting time: 50 ms or 300 ms

### Power supply H $\rightarrow$

AC/DC power pack (DC or 40...400 Hz)

Table 1: Rated voltages and permissible variations

Rated voltage	Tolerance
85 ... 230 V DC / AC	DC - 15 ... + 33%
24 ... 60 V DC / AC	AC $\pm 15\%$

Option: Connected to the low tension terminal side 12 and 13  
24 V AC or 24...60 V DC

Power consumption:  $\leq 1.5$  W resp.  $\leq 3$  VA

### Accuracy (acc. to EN 60 688)

Reference value: Output end value

Basic accuracy: Class 0.5

### Reference conditions:

Ambient temperature: 15 ... 30 °C

Input variable: Rated operating range

Frequency:  $f_N \pm 2$  Hz

Curve shape: Sine-wave

Crest factor:  $\sqrt{2}$

Power supply: In rated range

Output burden: Current:  $0.5 \cdot R_{\text{ext max.}}$   
Voltage:  $2 \cdot R_{\text{ext min.}}$

Warm-up time:  $\leq 5$  min.

### Influence effects (maxima): included in basic error

Frequency: 40 ... 400 Hz,  $\pm 0.3\%$   
30 ... 1000 Hz,  $\pm 0.5\%$

Crest factor: 1 ... 2.5,  $\pm 0.2\%$   
> 2.5 ... 6,  $\pm 0.5\%$

### Safety

Protection class: II (protection isolated, EN 61 010)

Housing protection: IP 40, housing (test wire, EN 60 529)  
IP 20, terminals (test finger, EN 60 529)

Contamination level: 2

Overvoltage category: III

Rated insulation voltage (versus earth): 300 V, input  
230 V, power supply  
40 V, output

# SINEAX I 552

## Transducer for AC current

Test voltage: 50 Hz, 1 min. acc. to EN 61 010-1  
3700 V, input versus all other circuits as well as outer surface  
3700 V, power supply versus output as well as outer surface  
490 V, output versus outer surface

### Connecting terminals

Connection elements: Screw-type terminals with indirect wire pressure  
Permissible cross section of the connection leads:  $\leq 4.0 \text{ mm}^2$  single wire or  $2 \times 2.5 \text{ mm}^2$  fine wire

### Installation data

Mechanical design: Housing **P13/70**  
Material of housing: Lexan 940 (polycarbonate), flammability Class V-0 acc. to UL 94, self-extinguishing, non-dripping, free of halogen  
Mounting: For rail mounting  
Mounting position: Any  
Weight: Approx. 0.3 kg

### Environmental conditions

Operating temperature:  $-10$  to  $+55 \text{ }^\circ\text{C}$   
Storage temperature:  $-40$  to  $+70 \text{ }^\circ\text{C}$   
Relative humidity of annual mean:  $\leq 75\%$   
Altitude: 2000 m max.  
Indoor use statement!

### Table 2: Standard version

The following transducer version is available as standard version. It is only necessary to quote the **Order No.:**

Nominal frequency	Measuring range by changing connections	Output signal	Power supply DC or 40...400 Hz	Setting time	Order No.
50/60 Hz	0 ... 1.0 A / 5 A	4 ... 20 mA	85 ... 230 V	300 ms	133 760

The complete order code 552-4... according to "Table 3: Specification and ordering information" must be stated for versions other than the basic version and for special configurations.

### Table 3: Specification and ordering information (see also Table 2: Standard version)

Description	*Blocking code	No-go with blocking code	Article No./ Feature
<b>SINEAX I 552</b>	<b>Order Code 552 - xxxx xx</b>		552 -
<b>Features, Selection</b>			
<b>1. Mechanical design</b> Housing P13/70 for rail mounting			4
<b>2. Nominal input frequency</b> 50 / 60 Hz			1
400 Hz			3
<b>3. Measuring range</b> 0 ... 1 / 5 A			1
0 ... 1.2 / 6 A			2
Non-standard 0 ... 0.1/0.5 to 0 ... < 1.2 / 6 Measuring range end value ratio 1 : 5	[A]		9
<b>4. Output signal</b> 0 ... 20 mA, $R_{\text{ext}} \leq 750 \Omega$			1
4 ... 20 mA, $R_{\text{ext}} \leq 750 \Omega$			2
Non-standard 0 ... 1.00 to 0 ... < 20 0.2 ... 1 to < (4 ... 20)	[mA]		9
0 ... 10 V, $R_{\text{ext}} \geq 5 \text{ k}\Omega$			A
Non-standard 0 ... 1.00 to 0 ... < 10 0.2 ... 1 to 2 ... 10	[V]		Z

# SINEAX I 552

## Transducer for AC current

Description	*Blocking code	No-go with blocking code	Article No./ Feature
<b>SINEAX I 552</b>	<b>Order Code 552 - xxxx xx</b>		552 -
<b>Features, Selection</b>			
<b>5. Power supply</b>			
85 ... 230 V DC/AC			1
24 ... 60 V DC/AC			2
24 V AC / 24 ... 60 V DC, low tension			5
<b>6. Setting time</b>			
0.3 s			1
50 ms			2

\* Lines with letter(s) under «no-go» cannot be combined with preceding lines having the same letter under "Blocking code".

### Electrical connections

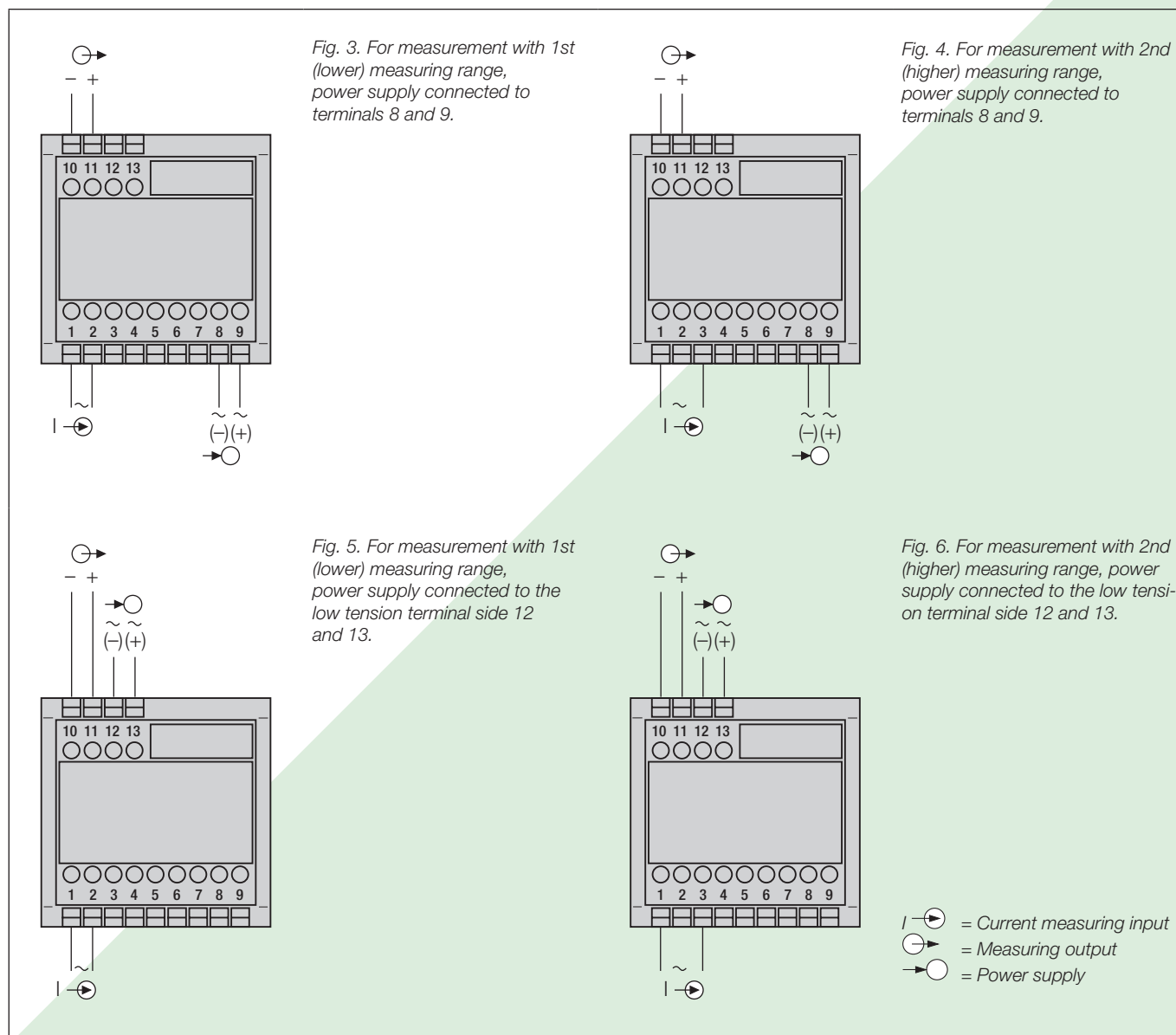

# SINEAX I 552 Transducer for AC current

## Dimensional drawing

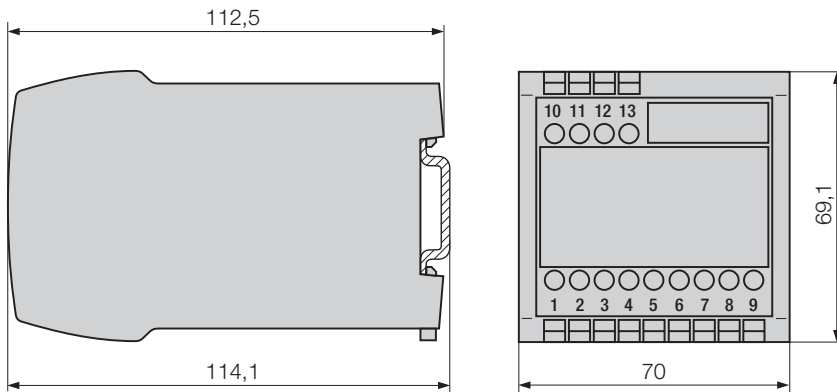

Fig. 7. SINEAX I 552 in housing **P13/70** clipped onto a top-hat rail (35 × 15 mm or 35 × 7.5 mm, acc. to EN 50 022).

 **CAMILLE BAUER**  
Rely on us.

Camille Bauer AG  
Aargauerstrasse 7  
CH-5610 Wohlen / Switzerland  
Phone: +41 56 618 21 11  
Fax: +41 56 618 35 35  
e-Mail: [info@camillebauer.com](mailto:info@camillebauer.com)  
[www.camillebauer.com](http://www.camillebauer.com)