

SINEAX I 542

Transducer for AC current

Self-powered
With 2 measuring ranges
Carrying rail housing P8/35



Fig. 1. SINEAX I 542 transducer in housing P8/35 clipped onto a top-hat rail.

Application

The transducer **SINEAX I 542** (Fig. 1) converts a sinusoidal AC current signal into an output signal that can serve several receiving instruments such as indicators, recorders, alarm units etc.

The transducer fulfils all the important requirements and regulations concerning electromagnetic compatibility **EMC** and **Safety** (IEC 1010 resp. EN 61 010). It was developed and is manufactured and tested in strict accordance with the **quality assurance standard** ISO 9001.

Features / Benefits

- Measuring input: 2 measuring ranges, 1/5 A or 1.2/6 A
- Self-powered / Less wiring expense
- Low power consumption / Smaller CT's can be used
- Standard version as per Germanischer Lloyd

Layout and mode of operation

The transducer comprises a transformer W, a rectifier unit G and an amplifier V (Fig. 2).

The measured variable is isolated from the electronics by the transformer, and is rectified and smoothed in the rectifier unit. The amplifier amplifies the resultant signal and converts it into the load-independent DC signal.

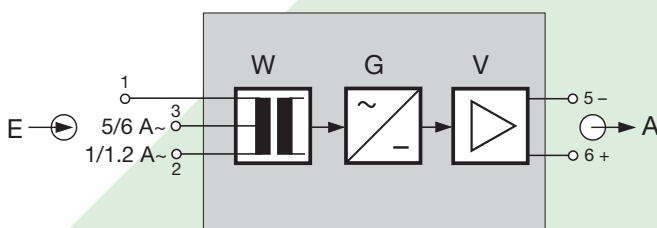

Fig. 2. Block diagram.

Table 1: Standard versions

The following transducer versions are available as standard versions. It is only necessary to quote the **Order No.:**

Description	Measuring range, selectable at terminals	Output signal	Order No.
Transducer for AC current, nominal frequency 50 / 60 Hz in housing P8/35	0...1 A / 5 A	0... 5 mA	129 595
	0...1 A / 5 A	0...10 mA	129 602
	0...1 A / 5 A	0...20 mA	129 610
	0...1.2 A / 6 A	0... 5 mA	136 417
	0...1.2 A / 6 A	0...10 mA	136 425
	0...1.2 A / 6 A	0...20 mA	136 433

Please complete the Order Code 542-4... acc. to "Table 2: Specification and ordering information" for versions with user-specific input ranges and/or variable sensitivity.

Technical data

Measuring input E

Nominal frequency: 50 / 60 Hz

Nominal input current I_N (measuring range end value): Measuring range limit values 0...0.5 to 0...7.5 A (only one measuring range)

SINEAX I 542

Transducer for AC current

Own consumption at nominal frequency 50 Hz:

I_{AN} [mA]	[VA]
1	1.5
5	1.7
10	2.0
20	2.5

Setting
(Special feature):

Admissible alteration of full-scale output, variable sensitivity, adjustable with potentiometer

Setting range
approx. $0,9 \dots 1,1 \cdot I_N$
(approx. $\pm 10\%$)

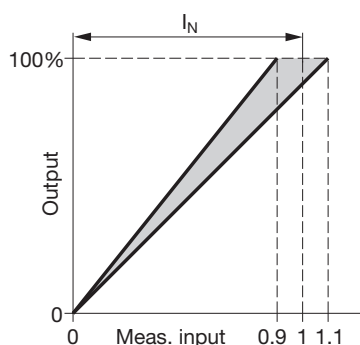

Overload capacity:

Mea- sured quantity I_N	Number of applications	Duration of one application	Interval between two successive applications
$1.2 \times I_N$	—	continuously	—
$20 \times I_N$	10	1 s	100 s

Measuring output A \ominus

Standard ranges:	0 ... 1, 0 ... 5, 0 ... 10 or 0 ... 20 mA
Burden voltage:	15 V
External resistance:	$R_{ext} \text{ max. [k}\Omega] = \frac{15 \text{ V}}{I_{AN} \text{ [mA]}}$ I_{AN} = full output value
Not superimposed DC voltage U_A :	0 ... 10 V External resistance $\geq 200 \text{ k}\Omega$
Current limiter under overload:	$\leq 1.7 \cdot I_{AN}$
Voltage limit under $R_{ext} = \infty$:	$\leq 30 \text{ V}$
Residual ripple:	$\leq 1\% \text{ p.p.}$
Response time:	$\leq 300 \text{ ms}$

Accuracy (acc. to EN 60 688)

Reference value:	Output end value
Basic accuracy:	Class 0.5

Reference conditions:

Ambient temperature	15 ... 30 °C
Input	0 ... 100%
Frequency	$f_N \pm 2 \text{ Hz}$
Output burden	Current: $0.5 \cdot R_{ext} \text{ max.}$ Voltage: $2 \cdot R_{ext} \text{ min.}$

Additional error:

Temperature influence (-10 ... 55 °C)	$\pm 0.2\% / 10 \text{ K}$
--	----------------------------

Safety

Protection class:	II (protection isolated, EN 61 010)
Housing protection:	IP 40, housing (test wire, EN 60 529) IP 20, terminals (test finger, EN 60 529)
Pollution degree:	2
Installation category:	III
Test voltage:	50 Hz, 1 min. acc. to EN 61 010-1

Installation data

Mechanical design:	Housing P8/35
Material of housing:	Lexan 940 (polycarbonate), flammability class V-0 acc. to UL 94, self-extinguishing, non-dripping, free of halogen
Mounting:	For rail mounting
Mounting position:	Any
Weight:	Approx. 0.26 kg

Connecting terminals

Connection elements:	Screw-type terminals with indirect wire pressure
Permissible cross section of the connection leads:	$\leq 4.0 \text{ mm}^2$ single-wire or $2 \times 2,5 \text{ mm}^2$ fine-wire

Environmental conditions

Operating temperature:	-10 to +55 °C
Storage temperature:	-40 to +70 °C
Relative humidity of annual mean:	$\leq 75\%$
Altitude:	2000 m max.
Indoor use statement!	

SINEAX I 542

Transducer for AC current

Table 2: Specification and ordering information (see also Table 1: "Standard versions")

Description	Blocking code	No-go with blocking code	Article No./ Feature
SINEAX I 542	Order Code 542 - xxxx x		542 -
Features, Selection			
1. Mechanical design			
Housing P8/35 for rail mounting			4
2. Measuring range			
0 ... 1 / 5 A			1
0 ... 1.2 / 6 A			2
Non-standard 0 ... 0.5 to 0 ... 7.5 A [A]			9
(for one measuring range only)			
Lines 1 and 2: Lower or higher range depending on connection			
3. Output signal			
0 ... 5 mA, $R_{ext} \leq 3 \text{ k}\Omega$			1
0 ... 10 mA, $R_{ext} \leq 1.5 \text{ k}\Omega$			2
0 ... 20 mA, $R_{ext} \leq 750 \Omega$			3
0 ... 1 mA, $R_{ext} \leq 15 \text{ k}\Omega$			4
0 ... 10 V, $R_{ext} \geq 200 \text{ k}\Omega$			A
Non-standard 0 ... 1 to 0 ... < 10 [M]			Z
4. Measuring range adjustable			
Measuring range end value permanently set			0
Measuring range can be adjusted approx. $\pm 10\%$			1
5. Test records			
Without test records			0
Test records in German			D
Test records in English			E

Electrical connections

Connection	Connecting terminals
Measuring input E \rightarrow	1 and 2 or 1 and 3 acc. to version, see type label
Measuring output A \rightarrow	5- and 6+

Standard accessories

1 Operating Instructions in three languages: German, French, English

Dimensional drawing

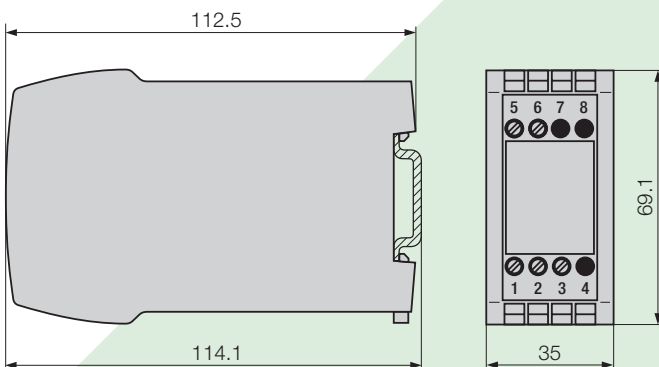

Fig. 3. SINEAX I 542 in housing P8/35 clipped onto a top-hat rail (35 x 15 mm or 35 x 7.5 mm, acc. to EN 50 022).

CAMILLE BAUER

Rely on us.

Camille Bauer AG
Aargauerstrasse 7
CH-5610 Wohlen / Switzerland

Phone: +41 56 618 21 11

Fax: +41 56 618 35 35

e-Mail: info@camillebauer.com

www.camillebauer.com