

SINEAX G 537

Transducer for Phase Angle Difference

Carrying rail housing P13/70

Application

The transducer **SINEAX G 537** (Fig. 1) converts the phase angle difference of two synchronised supplies into a **load independent** DC current or a **load independent** DC voltage proportional to the measured value.

The transducer fulfils all the important requirements and regulations concerning electromagnetic compatibility **EMC** and **Safety** (IEC 1010 resp. EN 61 010). It was developed and is manufactured and tested in strict accordance with the **quality assurance standard** ISO 9001.



Fig. 1. Transducer SINEAX G 537 in housing P13/70 clipped onto a top-hat rail.

Features / Benefits

- **Measuring inputs:** Sine, rectangular or distorted wave forms of nominal input voltages with dominant fundamental waves

Measured variables	Nominal input voltages	Measuring range limits
Phase angle difference	10 to 690 V	± 10 to $< \pm 180^\circ\text{el}$

- **Measuring output:** Unipolar, bipolar or live zero output variables
- **Measuring principle:** Measurement of the zero crossing interval
- **AC/DC power supply / Universal**
- **Standard as marine version per Lloyd's Register of Shipping**

Nominal input voltage U_N : Generator and bus bar
10 ... 230 V or 230 ... 690 V
(max. 230 V with power supply from voltage measuring input)

Sensitivity: 10 ... 120% U_N

Own consumption: $< U_N \cdot 1.5$ mA per measuring input

Overload capacity:

Measured quantities U_N	Number of applications	Duration of one application	Interval between two successive applications
$1,2 \times U_N^1$	—	perman.	—
$2 \times U_N^1$	10	1 s	10 s

¹ But max. 264 V with power supply from voltage measuring input.

Technical data

General

Measured quantity: Phase angle difference
Measuring principle: Measurement of the zero crossing interval

Measuring inputs \rightarrow

Measuring range: See Section «Specification and ordering information»
Nominal frequency f_N : 50 or 60 Hz

Measuring output \rightarrow

Load independent
DC current: 0 ... 1 to 0 ... 20 mA resp. live-zero
1 ... 5 to 4 ... 20 mA
 ± 1 to ± 20 mA
Burden voltage: + 15 V, resp. - 12 V
Load independent
DC voltage: 0 ... 1 to 0 ... 10 V resp. live-zero
0.2 ... 1 to 2 ... 10 V
 ± 1 to ± 10 V

SINEAX G 537

Transducer for Phase Angle Difference

Load capacity:	Max. 4 mA
Voltage limit under $R_{\text{ext}} = \infty$:	$\leq 25 \text{ V}$
Current limit under overload:	Approx. $1.3 \times I_{\text{AN}}$ at current output Approx. 30 mA at voltage output
Residual ripple in output current:	$< 0.5\% \text{ p.p.}$
Nominal value of response time:	4 periods of the measuring frequency
Other ranges:	2, 8 or 16 periods of the measuring frequency

Behaviour of output current in different operating states:

Operating state ¹		Output	
Generator voltage U _G	Bus bar voltage U _S	unipolar	bipolar
leading ($f_G = f_S$)		$> I_{\text{AN}} / 2$	positive
missing ²	nominal value		
nominal value	missing ²	indefinite	indefinite
missing ²	missing ²		

¹ With power supply switched on

² E.g. switched off or fault condition

Accuracy (acc. to EN 60 688)

Reference value:	$\Delta\varphi = 90^\circ$
Basic accuracy:	Class 0.5

Reference conditions

Ambient temperature	15 ... 30 °C
Input voltage	$U_G = 0.8 \dots 1.2 U_S$
Frequency	$f_N \pm 10\%$
Wave form	Sine
Power supply	At nominal range
Output burden	$\Delta R_{\text{ext}} \text{ max.}$

Safety

Protection class:	II (protection isolated, EN 61 010)
Housing protection:	IP 40, housing (test wire, EN 60 529) IP 20, terminals (test finger, EN 60 529)
Contamination level:	2
Overvoltage category:	III
Rated insulation voltage (against earth):	230 V resp. 400 V, inputs 230 V, power supply 40 V, output

Test voltage:	50 Hz, 1 min. acc. to EN 61 010-1 3700 resp. 5550 V, inputs versus all other circuits as well as outer surface 3250 V, inputs versus each other 3700 V, power supply versus output as well as outer surface 490 V, output versus outer surface
---------------	--

Power supply $\rightarrow \bigcirc$

AC/DC power pack (DC or 40 ... 400 Hz)

Table 1: Rated voltages and permissible variations

Rated voltage	Tolerance
85 ... 230 V DC, AC	DC – 15 ... + 33%
24 ... 60 V DC, AC	AC $\pm 15\%$

or

Power supply from voltage measuring input:	24...60 V AC or 85...230 V AC
Option:	Connect to the low tension to terminals 12 and 13 24 V AC or 24 ... 60 V DC
Power consumption:	Approx. 2 W resp. 4 VA

Installation data

Mechanical design:	Housing P13/70
Material of housing:	Lexan 940 (polycarbonate), flammability Class V-0 acc. to UL 94, self-extinguishing, non-dripping, free of halogen
Mounting:	For rail mounting
Mounting position:	Any
Weight:	Approx. 0.27 kg

Connecting terminals

Connection element:	Screw-type terminals with indirect wire pressure
Permissible cross section of the connection leads:	$\leq 4.0 \text{ mm}^2$ single wire or $2 \times 2.5 \text{ mm}^2$ fine wire

Environmental conditions

Operating temperature:	– 10 to + 55 °C
Storage temperature:	– 40 to + 70 °C
Relative humidity of annual mean:	$\leq 75\%$
Altitude:	2000 m max.
Indoor use statement!	

Ambient tests

EN 60 068-2-6:	Vibration
Acceleration:	$\pm 2 \text{ g}$

SINEAX G 537

Transducer for Phase Angle Difference

Frequency range:	10 ... 150 ... 10 Hz, rate of frequency sweep: 1 octave/minute	Germanischer Lloyd	Type approval certificate:	No. 12 261-98 HH
Number of cycles:	10, in each of the three axes		Ambient category:	C
EN 60 068-2-27:	Shock		Vibration:	0.7 g
Acceleration:	3 x50 g 3 chocs each in 6 directions			
EN 60 068-2-1/-2/-3:	Cold, dry heat, damp heat			
IEC 1000-4-2/-3/-4/-5/-6				
EN 55 011:	Electromagnetic compatibility			

Output characteristic

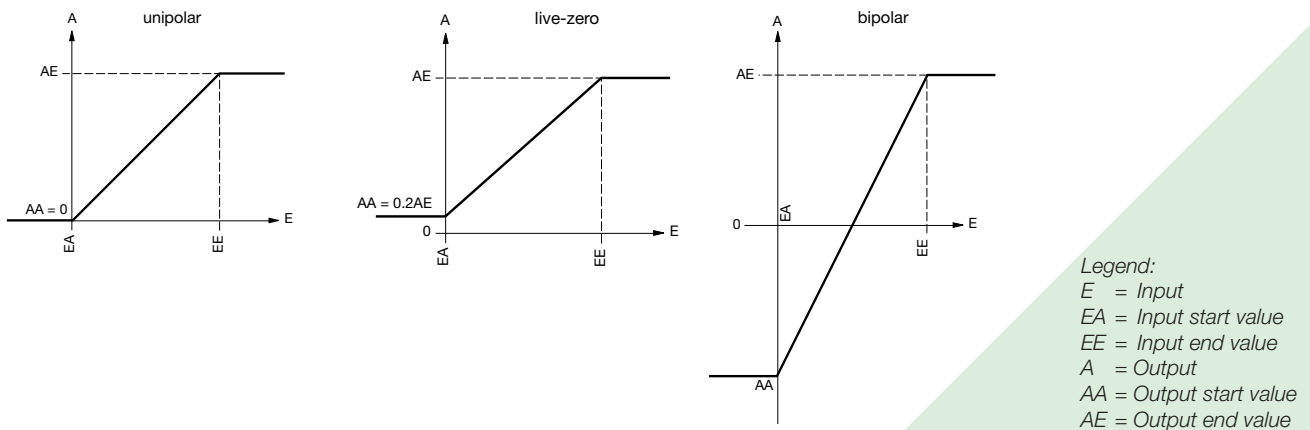

Table 2: Specification and ordering information

Description	*Blocking code	no-go with blocking code	Article No./ Feature
SINEAX G 537			537 -
Order code 537 - xxxx xxx			
Features, Selection			
1. Mechanical design			
Housing P13/70 for rail mounting			4
2. Nominal input frequency			
50 Hz			1
60 Hz			2
Non-standard [Hz] ≥ 10 to 1500 Hz With power supply from measuring input min. 40 Hz, max. 400 Hz			9
3. Nominal input voltage			
Generator and bus bar:			
$U_N = 100\text{ V}$	A		1
$U_N = 230\text{ V}$	A		2
Non-standard [M] ≥ 10 to 690 V With power supply from measuring input min. 24 V, max. 230 V, see feature 6, lines 3 and 4			9
3 phase system: Input voltage = phase to phase voltage			

SINEAX G 537

Transducer for Phase Angle Difference

Description	*Blocking code	no-go with blocking code	Article No./ Feature
SINEAX G 537 Order code 537 - xxxx xxx			537 -
Features, Selection			
4. Measuring range – 120 ... 0 ... 120 °el			1
Non-standard [°el] Measuring range within – 180 ... 0 ... + 180 °el, but unambiguous output value up to – 175 ... 0 ... + 175 °el; measuring span ≤ 20 °el			9
5. Output signal 0 ... 20 mA			1
4 ... 20 mA			2
Non-standard 0 ... 1.00 to 0 ... < 20, [mA] – 1.00 ... 0 ... 1.00 to – 20 ... 0 ... 20 (symmetrical) 1 ... 5 to < (4 ... 20) (AA / AE = 1 / 5)			9
0 ... 10 V			A
Non-standard 0 ... 1.00 to 0 ... < 10, [V] – 1.00 ... 0 ... 1.00 to – 10 ... 0 ... 10 (symmetrical) 0.2 ... 1 to 2 ... 10 (AA / AE = 1 / 5) AA = Output start value, AE = Output end value			Z
6. Power supply 85 ... 230 V DC, AC			1
24 ... 60 V DC, AC			2
Internal from measuring input (24 ... 60 V AC)		A	3
Internal from measuring input (85 ... 230 V AC)			4
Connect to the low tension 24 V AC / 24 ... 60 V DC			5
7. Response time 4 periods of the input frequency (standard)			1
2 periods of the input frequency			2
8 periods of the input frequency			3
16 periods of the input frequency			4

* Lines with letter(s) under "no-go" cannot be combined with preceding lines having the same letter under "SCODE".

SINEAX G 537

Transducer for Phase Angle Difference

Electrical connections

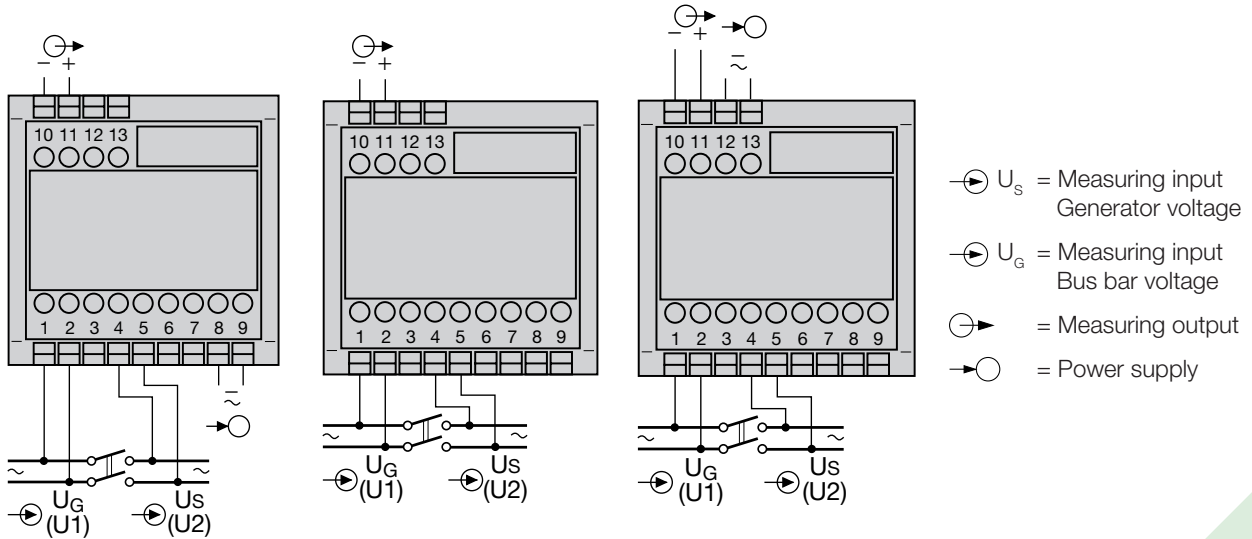

Fig. 2. Power supply connected to terminals 8 and 9.

Fig. 3. Power supply internal from measuring input, without separated power supply.

Fig. 4. Power supply connected to the low tension terminal side 12 and 13

Dimensional drawing

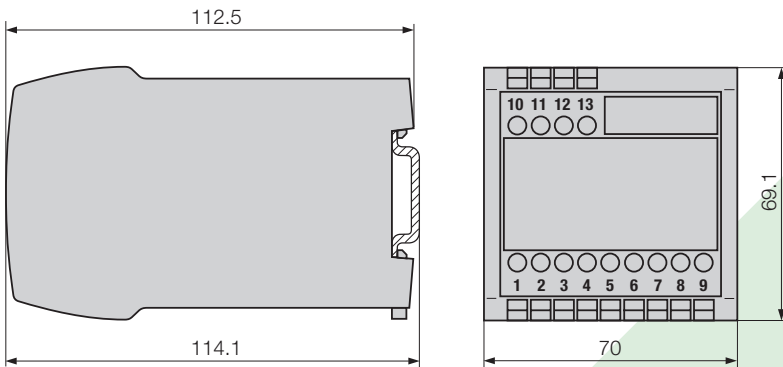

Fig. 5. Housing **P13/70** clipped onto a top-hat rail (35 x 15 or 35 x 7.5 mm, acc. to EN 50 022).

Standard accessories

1 Operating Instructions in three languages: German, French, English

CAMILLE BAUER
Rely on us.

Camille Bauer Ltd.
Aargauerstrasse 7
CH-5610 Wohlen / Switzerland
Phone: +41 56 618 21 11
Fax: +41 56 618 35 35
e-Mail: info@camillebauer.com
www.camillebauer.com