

SINEAX DME 401 with RS 485 Interface

Programmable Multi-Transducer

without analog outputs, transfer of data via a MODBUS®-interface



Application

SINEAX DME 401 (Fig. 1) is a programmable transducer with a **RS 485 bus interface (MODBUS®)**. It supervises several variables of an electrical power system **simultaneously**.

The **RS 485** interface enables the user to determine the number of variables to be supervised (up to the maximum available). The levels of all internal counters that have been configured (max. 4) can also be viewed. Provision is made for programming the SINEAX DME 401 via the bus. A standard EIA 485 interface can be used.

The transducers are also equipped with an **RS 232** serial interface to which a PC with the corresponding software can be connected for programming or accessing and executing useful ancillary functions. This interface is needed for bus operation to configure the device address, the Baud rate and possibly increasing the telegram waiting time (if the master is too slow) defined in the MODBUS® protocol.

The usual methods of connection, the types of measured variables, their ratings and the type of internal energy/metering are the main parameters that can be programmed.

The ancillary functions include a power system check and a facility for printing nameplate.

The transducer fulfils all the essential requirements and regulations concerning electromagnetic compatibility (**EMC**) and **safety** (IEC 1010 resp. EN 61 010). It was developed and is manufactured and tested in strict accordance with the **quality assurance standard** ISO 9001.



Fig. 1. SINEAX DME 401 in housing T24, clipped onto a top-hat rail.

Measured variables	Output	Types
	Without analog outputs, with bus interface RS 485 (MODBUS)	DME 401
Current, voltage (rms), active/reactive/apparent power $\cos\varphi$, $\sin\varphi$, power factor	4 analog outputs and bus interface RS 485 (MODBUS) see data sheet DME 440-1 Le	DME 440
RMS value of the current with wire setting range (bimetal measuring function)	2 analog outputs and 4 digital outputs	DME 424
Slave pointer function for the measurement of the RMS value IB	4 analog outputs and 2 digital outputs see data sheet DME 424/442-1 Le	DME 442
Frequency		
Average value of the currents with sign of the active power (power system only)	Data bus LON see data sheet DME 400-1 Le	DME 400
	PROFIBUS DP see data sheet DME 406-1 Le	DME 406

Features / Benefits

- Simultaneous measurement of several variables of a heavy-current power system / Full supervision of an asymmetrically loaded four-wire power system. rated current 1 to 6 A, rated voltage 57 to 400 V (phase-to-neutral) or 100 to 693 V (phase-to-phase)
- For all heavy-current power system variables
- Input voltage up to 693 V (phase-to-phase)
- Transfer of data via a MODBUS® interface
- High accuracy: 0.2% (under reference conditions)

SINEAX DME 401 with RS 485 Interface

Programmable Multi-Transducer

- 4 integrated energy meters, storage every each 203 s, storage for 20 years
- Windows software with password protection for programming, data analysis, power system status simulation, acquisition of meter data and making settings
- DC-, AC-power pack with wide power supply tolerance / Universal
- Provision for either snapping the transducer onto top-hat rails or securing it with screws to a wall or panel

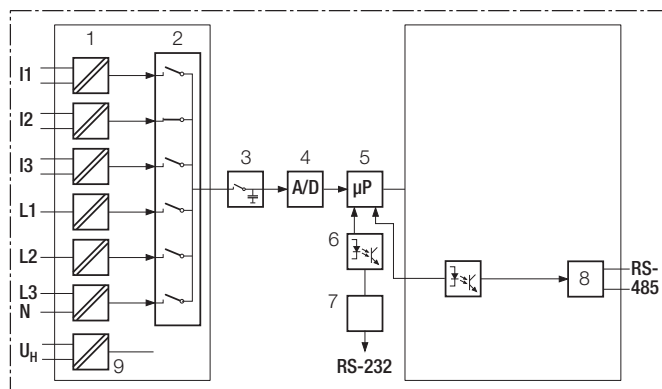

- 1 = Input transformer
 2 = Multiplexer
 3 = Latching stage
 4 = A/D converter
 5 = Microprocessor
 6 = Electrical insulation
 7 = Programming interface RS-232
 8 = Bus RS 485 (MODBUS)
 9 = Power supply

Fig. 2. Block diagram.

Symbols

Symbols	Meaning
X	Measured variable
X0	Lower limit of the measured variable
X1	Break point of the measured variable
X2	Upper limit of the measured variable
U	Input voltage
Ur	Rated value of the input voltage
U 12	Phase-to-phase voltage L1 and L2
U 23	Phase-to-phase voltage L2 and L3
U 31	Phase-to-phase voltage L3 and L1
U1N	Phase-to-neutral voltage L1 – N
U2N	Phase-to-neutral voltage L2 – N
U3N	Phase-to-neutral voltage L3 – N
UM	Average value of the voltages (U1N + U2N + U3N) / 3

Symbols	Meaning
I	Input current
I1	AC current L1
I2	AC current L2
I3	AC current L3
Ir	Rated value of the input current
IM	Average value of the currents (I1 + I2 + I3) / 3
IMS	Average value of the currents and sign of the active power (P)
IB	RMS value of the current with wire setting range (bimetal measuring function)
IBT	Response time for IB
BS	Slave pointer function for the measurement of the RMS value IB
BST	Response time for BS
φ	Phase-shift between current and voltage
F	Frequency of the input variable
Fn	Rated frequency
P	Active power of the system $P = P1 + P2 + P3$
P1	Active power phase 1 (phase-to-neutral L1 – N)
P2	Active power phase 2 (phase-to-neutral L2 – N)
P3	Active power phase 3 (phase-to-neutral L3 – N)
Q	Reactive power of the system $Q = Q1 + Q2 + Q3$
Q1	Reactive power phase 1 (phase-to-neutral L1 – N)
Q2	Reactive power phase 2 (phase-to-neutral L2 – N)
Q3	Reactive power phase 3 (phase-to-neutral L3 – N)
S	Apparent power of the system $S = \sqrt{I_1^2 + I_2^2 + I_3^2} \cdot \sqrt{U_1^2 + U_2^2 + U_3^2}$
S1	Apparent power phase 1 (phase-to-neutral L1 – N)
S2	Apparent power phase 2 (phase-to-neutral L2 – N)
S3	Apparent power phase 3 (phase-to-neutral L3 – N)
Sr	Rated value of the apparent power of the system
PF	Active power factor $\cos \varphi = P/S$
PF1	Active power factor phase 1 $P1/S1$
PF2	Active power factor phase 2 $P2/S2$
PF3	Active power factor phase 3 $P3/S3$
QF	Reactive power factor $\sin \varphi = Q/S$
QF1	Reactive power factor phase 1 $Q1/S1$
QF2	Reactive power factor phase 2 $Q2/S2$
QF3	Reactive power factor phase 3 $Q3/S3$

SINEAX DME 401 with RS 485 Interface Programmable Multi-Transducer

Symbols	Meaning
LF	Power factor of the system $LF = \text{sgn}Q \cdot (1 - PF)$
LF1	Power factor phase 1 $\text{sgn}Q1 \cdot (1 - PF1)$
LF2	Power factor phase 2 $\text{sgn}Q2 \cdot (1 - PF2)$
LF3	Power factor phase 3 $\text{sgn}Q3 \cdot (1 - PF3)$
H	Power supply
Hn	Rated value of the power supply
CT	c.t. ratio
VT	v.t. ratio

Applicable standards and regulations

IEC 688 or EN 60 688	Electrical measuring transducers for converting AC electrical variables into analog and digital signals
IEC 1010 or EN 61 010	Safety regulations for electrical measuring, control and laboratory equipment
IEC 529 or EN 60529	Protection types by case (code IP)
IEC 255-4 Part E5	High-frequency disturbance test (static relays only)
IEC 1000-4-2, 3, 4, 6	Electromagnetic compatibility for industrial process measurement and control equipment
EN 55 011	Electromagnetic compatibility of data processing and telecommunication equipment
	Limits and measuring principles for radio interference and information equipment
IEC 68-2-1, 2, 3, 6, 27 or EN 60 068-2-1, 2, 3, 6, 27	Ambient tests -1 Cold, -2 Dry heat, -3 Damp heat, -6 Vibration, -27 Shock
DIN 40 110	AC quantities
DIN 43 807	Terminal markings
IEC 1036	Alternating current static watt-hour meters for active energy (classes 1 and 2)
DIN 43 864	Current interface for the transmission of impulses between impulse encoder counter and tarif meter
UL 94	Tests for flammability of plastic materials for parts in devices and appliances

Technical data

Inputs \rightarrow

Input variables:	see Table 3 and 4
Measuring ranges:	see Table 3 and 4
Waveform:	Sinusoidal
Nominal frequency:	50, 60 or 16 2/3 Hz
Consumption [VA]:	Voltage circuit: $U^2 / 400 \text{ k}\Omega$ Condition: external power supply Current circuit: $\leq I^2 \cdot 0.01 \Omega$

Continuous thermal ratings of inputs

Current circuit	10 A	400 V single-phase AC system 693 V three-phase system
Voltage circuit	480 V	single-phase AC system
	831 V	three-phase system

Short-time thermal rating of inputs

Input variable	Number of inputs	Duration of overload	Interval between two overloads
Current circuit 400 V single-phase AC system 693 V three-phase system			
100 A	5	3 s	5 min.
250 A	1	1 s	1 hour
Voltage circuit 1 A, 2 A, 5 A			
Single-phase AC system 600 V $H_{\text{intern}}: 1.5 U_r$	10	10 s	10 s
Three-phase system 1040 V $H_{\text{intern}}: 1.5 U_r$	10	10 s	10 s

MODBUS® (bus interface RS-485)

Terminals:	Screw terminals, terminals 23, 24, 25 and 26
Connecting cable:	Screened twisted pair
Max. distance:	Approx. 1200 m (approx. 4000 ft.)
Baudrate:	1200 ... 9600 Bd (programmable)
Number of bus stations:	32 (including master)
Dummy load:	Not required

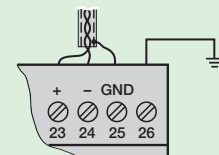

MODBUS® is a registered trademark of the Schneider Automation Inc.

SINEAX DME 401 with RS 485 Interface

Programmable Multi-Transducer

Reference conditions

Ambient temperature:	15 ... 30 °C
Pre-conditioning:	30 min. acc. to EN 60 688
Input variable:	Rated useful range
Power supply:	$H = H_n \pm 1\%$
Active/reactive factor:	$\cos\varphi = 1$ resp. $\sin\varphi = 1$
Frequency:	50 ... 60 Hz, 16 2/3 Hz
Waveform:	Sinusoidal, form factor 1.1107
Miscellaneous:	EN 60 688

System response

Accuracy class:	0.2 resp. 0.4 at applications with phase-shift
Duration of the measurement cycle:	Approx. 0.5 to 1.2 s at 50 Hz, depending on measured variable and programming
Response time:	1 ... 2 times the measurement cycle

Influencing quantities and permissible variations

Acc. to EN 60 688

Safety

Protection class:	II (protection isolated, EN 61 010-1)	
Enclosure protection:	IP 40, housing IP 20, terminals	
Installation category:	III	
Insulation test (versus earth):	Input voltage:	AC 400 V
	Input current:	AC 400 V
	RS 485:	DC 40 V
	Power supply:	AC 400 V DC 230 V
Surge test:	5 kV; 1.2/50 µs; 0.5 Ws	
Test voltage:	50 Hz, 1 min. acc. to EN 61 010-1	
	5550 V, inputs versus all other circuits as well as outer surface	
	3250 V, input circuits versus each other	
	3700 V, power supply versus RS 485 and SCI as well as outer surface	
	490 V, RS 485 versus SCI as well as outer surface	

Power supply →○

DC-, AC-power pack (DC and 50 ... 60 Hz)

Table 1: Rated voltages and tolerances

Rated voltage U_N	Tolerance
24 ... 60 V DC, AC	DC – 15 ... + 33%
85 ... 230 V DC, AC	AC ± 10%

Consumption: ≤ 9 W resp. ≤ 10 VA

Programming connector on transducer

Interface:	RS 232 C
DSUB socket:	9-pin

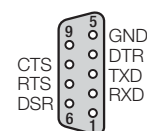

The interface is electrically insulated from all other circuits.

Installation data

Housing:	Housing T24 See section "Dimensioned drawings"
Housing material:	Lexan 940 (polycarbonate), flammability class V-0 acc. to UL 94, self-extinguishing, non-dripping, free of halogen
Mounting:	For snapping onto top-hat rail (35 × 15 mm or 35 × 7.5 mm) acc. to EN 50 022
	or directly onto a wall or panel using the pull-out screw hole brackets
Orientation:	Any
Weight:	Approx. 0.7 kg

Terminals

Type:	Screw terminals with wire guards
Max. wire gauge:	≤ 4.0 mm ² single wire or 2 × 2.5 mm ² fine wire

Ambient tests

EN 60 068-2-6:	Vibration
Acceleration:	± 2 g
Frequency range:	10 ... 150 ... 10 Hz, rate of frequency sweep: 1 octave/minute
Number of cycles:	10, in each of the three axes
EN 60 068-2-27:	Shock
Acceleration:	3 × 50 g 3 shocks each in 6 directions
EN 60 068-2-1/-2/-3:	Cold, dry heat, damp heat

Ambient conditions

Variations dues to ambient temperature:	± 0.2% / 10 K
Nominal range of use for temperature:	0 ... 15 ... 30 ... 45 °C (usage group II)

SINEAX DME 401 with RS 485 Interface

Programmable Multi-Transducer

Operating temperature:	- 10 to + 55 °C	Altitude:	2000 m max.
Storage temperature:	- 40 to + 85 °C	Indoor use statement!	
Annual mean relative humidity:	≤ 75%		

Table 2: SINEAX DME 401, available as standard versions (without analog outputs)

The versions of the transducer below programmed with the **basic** configuration are available ex stock. It is only necessary to quote the **Order No.:**

Description / Basic programming		Marking	Order No.
1. Mechanical design:	Housing T24 for rail and wall mounting	401-1	
2. Rated input frequency:	50 Hz	1	
3. Power supply:	24 ... 60 V DC, AC	7	146 523
	85 ... 230 V DC, AC	8	146 515
4. Power supply connection:	External connection (standard)	1	
5. Test certificate:	None supplied	0	
6. Configuration:	Programmed basic configuration	0	
See Table 3 "Ordering information"			
Basic configuration			
1. Application (system):	4-wire, 3-phase asymmetric load	A 44	
2. Rated input voltage:	Rated value $U_r = 100\text{ V}$	U 21	
3. Rated input current:	Rated value $I_r = 2\text{ A}$	V 2	
4. Primary rating:	Without specification of primary rating	W 0	
5. Energy meter 1:	Not used	EA 00	
6. Energy meter 2:	Not used	FA 00	
7. Energy meter 3:	Not used	GA 00	
8. Energy meter 4:	Not used	HA 00	
See Table 4 "Programming"			

Table 3: Ordering information

DESCRIPTION	MARKING
1. Mechanical design Housing T24 for rail and wall mounting	401 - 1
2. Rated input frequency 50 Hz (60 Hz possible without additional error; 16 2/3 Hz, additional error 1.25)	1
60 Hz (50 Hz possible without additional error; 16 2/3 Hz, additional error 1.25)	2
16 2/3 Hz (not re-programming by user, 50/60 Hz possible, but with additional error 1.25)	3
3. Power supply Nominal range 24 ... 60 V DC, AC	7
Nominal range 85 ... 230 V DC, AC	8
4. Power supply connection External (standard)	1
Internal from measuring input Not available for rated frequency 16 2/3 Hz and applications A15 / A16 / A24 (see Table 4)	2
Caution: The power supply voltage must agree with the input voltage (Table 4)!	
5. Test certificate None supplied	0
With test certificate in German	D
With test certificate in English	E

SINEAX DME 401 with RS 485 Interface

Programmable Multi-Transducer

DESCRIPTION	MARKING
6. Configuration	
Basic configuration, programmed (not available if the power supply is taken from the measuring input)	0
Programmed acc. to specification	9
All the programming data must be entered on Form W 2408e (see appendix) and the form must be included with the order!	

Table 4: Programmierung

DESCRIPTION	APPLICATION		
	A11... A16	A34	A24/A44
1. Application (system)			
Single-phase AC	A11	—	—
3-wire, 3-phase symmetric load, phase-shift U: L1-L2, I: L1*	A12	—	—
3-wire, 3-phase symmetric load	A13	—	—
4-wire, 3-phase symmetric load	A14	—	—
3-wire, 3-phase symmetric load, phase-shift U: L3-L1, I: L1*	A15	—	—
3-wire, 3-phase symmetric load, phase-shift U: L2-L3, I: L1*	A16	—	—
3-wire, 3-phase asymmetric load	—	A34	—
4-wire, 3-phase asymmetric load	—	—	A44
4-wire, 3-phase asymmetric load, open-Y	—	—	A24
2. Rated input voltage			
Rated value $U_r = 57.7$ V	U01	—	—
Rated value $U_r = 63.5$ V	U02	—	—
Rated value $U_r = 100$ V	U03	—	—
Rated value $U_r = 110$ V	U04	—	—
Rated value $U_r = 120$ V	U05	—	—
Rated value $U_r = 230$ V	U06	—	—
Rated value U_r (U_r [V] 57 to 400) [V]	U91	—	—
Rated value $U_r = 100$ V	U21	U21	U21
Rated value $U_r = 110$ V	U22	U22	U22
Rated value $U_r = 115$ V	U23	U23	U23
Rated value $U_r = 120$ V	U24	U24	U24
Rated value $U_r = 400$ V	U25	U25	U25
Rated value $U_r = 500$ V	U26	U26	U26
Rated value U_r (U_r [V] > 100 to 693) [V]	U93	U93	U93
Lines U01 to U06: Only for single phase AC current or 4-wire, 3-phase symmetric load			
3. Rated input current			
Rated value $I_r = 1$ A	V1	V1	V1
Rated value $I_r = 2$ A	V2	V2	V2
Rated value $I_r = 5$ A	V3	V3	V3
Rated value I_r (I_r [A] > 1 to 6) [A]	V9	V9	V9
4. Primary rating (voltage and current transformer)			
Without specification of primary rating	W0	W0	W0
CT = _____ A VT = _____ kV Specify transformer ratio primary, e.g. 33 kV/1000 A The secondary ratings must correspond to the rated input voltage and current specified for feature 2, respectively 3.	W9	W9	W9

SINEAX DME 401 with RS 485 Interface

Programmable Multi-Transducer

DESCRIPTION	APPLICATION		
	A11... A16	A34	A24/A44
5. Energy meter 1			
Not used	EA00	EA00	EA00
I System [Ah]	EA50	—	—
I1 L1 [Ah]	—	EA51	EA51
I2 L2 [Ah]	—	EA52	EA52
I3 L3 [Ah]	—	EA53	EA53
S System [VAh]	EA54	EA54	EA54
S1 L1 [VAh]	—	—	EA55
S2 L2 [VAh]	—	—	EA56
S3 L3 [VAh]	—	—	EA57
P System (incoming) [Wh]	EA58	EA58	EA58
P1 L1 (incoming) [Wh]	—	—	EA59
P2 L2 (incoming) [Wh]	—	—	EA61
P3 L3 (incoming) [Wh]	—	—	EA61
Q System (inductive) [Varh]	EA62	EA62	EA62
Q1 L1 (inductive) [Varh]	—	—	EA63
Q2 L2 (inductive) [Varh]	—	—	EA64
Q3 L3 (inductive) [Varh]	—	—	EA65
P System (outgoing) [Wh]	EA66	EA66	EA66
P1 L1 (outgoing) [Wh]	—	—	EA67
P2 L2 (outgoing) [Wh]	—	—	EA68
P3 L3 (outgoing) [Wh]	—	—	EA69
Q System (capacitive) [Varh]	EA70	EA70	EA70
Q1 L1 (capacitive) [Varh]	—	—	EA71
Q2 L2 (capacitive) [Varh]	—	—	EA72
Q3 L3 (capacitive) [Varh]	—	—	EA73
6. Energy meter 2			
Same as energy meter 1, but markings start with a capital F	FA ..	FA ..	FA ..
7. Energy meter 3			
Same as energy meter 1, but markings start with a capital G	GA ..	GA ..	GA ..
8. Energy meter 4			
Same as energy meter 1, but markings start with a capital H	HA ..	HA ..	HA ..

* Basic accuracy 0.4 c

Standard accessories

- 1 Operating Instructions for SINEAX DME 401 in three languages: German, French, English
- 1 blank type label, for recording programmed settings
- 1 interface definition DME 401: German, French or English

SINEAX DME 401 with RS 485 Interface

Programmable Multi-Transducer

Electrical connections

Function			Connect.
Measuring input ⊕	AC current	IL1	1 / 3
		IL2	4 / 6
		IL3	7 / 9
	AC voltage	UL1	2
		UL2	5
		UL3	8
	N	11	
RS 485 (MODBUS)	Tx + / Rx +		23
	Tx - / Rx -		24
	GND		25
			26
Power supply ⊖	AC	~	13
		~	14
	DC	+	13
		-	14

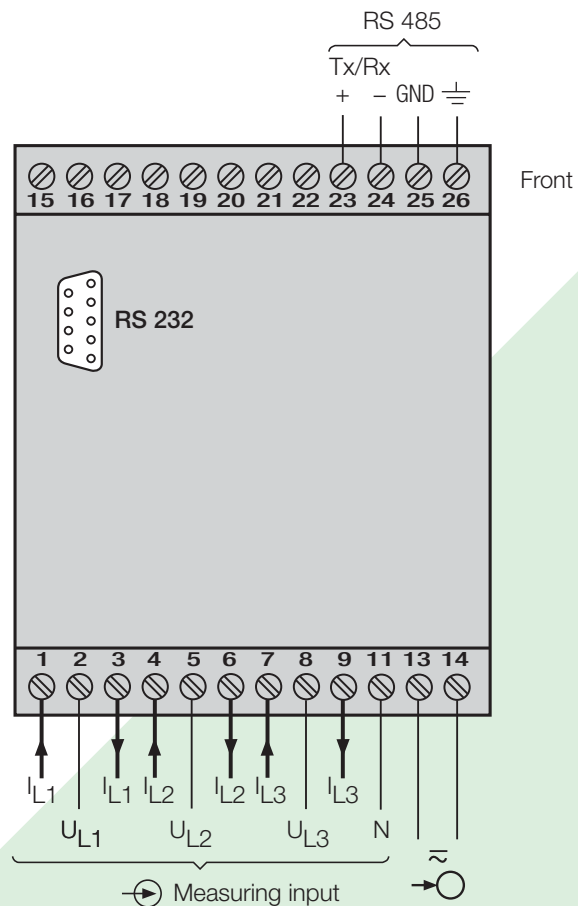

If power supply is taken from the measured voltage internal connections are as follows:

Application (system)	Internal connection Terminal / System
Single-phase AC current	2 / 11 (L1 - N)
4-wire 3-phase symmetric load	2 / 11 (L1 - N)
All other (apart from A15 / A16 / A24)	2 / 5 (L1 - L2)

Measuring inputs

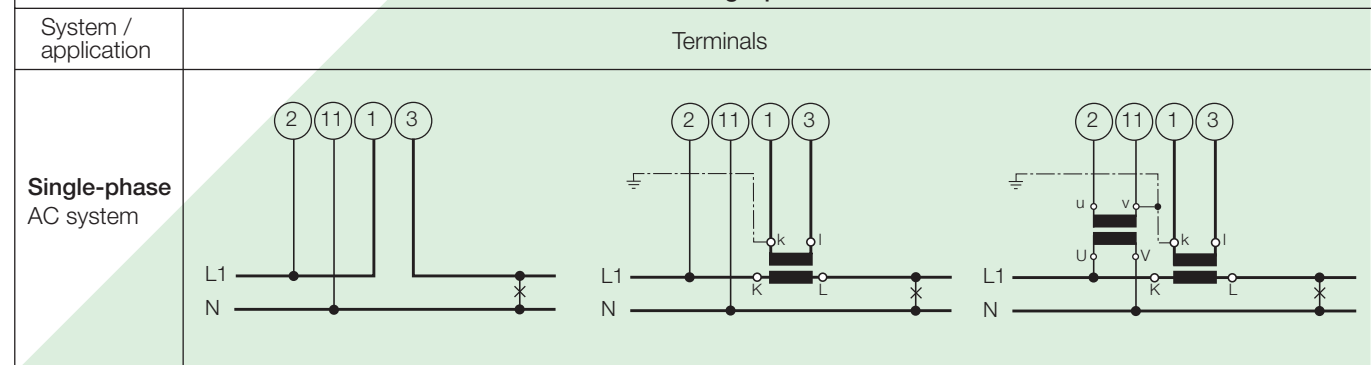

SINEAX DME 401 with RS 485 Interface Programmable Multi-Transducer

Measuring inputs																		
System / application	Terminals																	
3-wire 3-phase symmetric load I: L1	<p>Connect the voltage according to the following table for current measurement in L2 or L3:</p> <table border="1"> <thead> <tr> <th>Current transf.</th> <th>Terminals</th> <th>2</th> <th>5</th> <th>8</th> </tr> </thead> <tbody> <tr> <td>L2</td> <td>1</td> <td>3</td> <td>L2</td> <td>L3</td> <td>L1</td> </tr> <tr> <td>L3</td> <td>1</td> <td>3</td> <td>L3</td> <td>L1</td> <td>L2</td> </tr> </tbody> </table>	Current transf.	Terminals	2	5	8	L2	1	3	L2	L3	L1	L3	1	3	L3	L1	L2
Current transf.	Terminals	2	5	8														
L2	1	3	L2	L3	L1													
L3	1	3	L3	L1	L2													
3-wire 3-phase symmetric load Phase shift U: L1 – L2 I: L1	<p>Connect the voltage according to the following table for current measurement in L2 or L3:</p> <table border="1"> <thead> <tr> <th>Current transf.</th> <th>Terminals</th> <th>2</th> <th>5</th> </tr> </thead> <tbody> <tr> <td>L2</td> <td>1</td> <td>3</td> <td>L2</td> <td>L3</td> </tr> <tr> <td>L3</td> <td>1</td> <td>3</td> <td>L3</td> <td>L1</td> </tr> </tbody> </table>	Current transf.	Terminals	2	5	L2	1	3	L2	L3	L3	1	3	L3	L1			
Current transf.	Terminals	2	5															
L2	1	3	L2	L3														
L3	1	3	L3	L1														
3-wire 3-phase symmetric load Phase shift U: L3 – L1 I: L1	<p>Connect the voltage according to the following table for current measurement in L2 or L3:</p> <table border="1"> <thead> <tr> <th>Current transf.</th> <th>Terminals</th> <th>8</th> <th>2</th> </tr> </thead> <tbody> <tr> <td>L2</td> <td>1</td> <td>3</td> <td>L1</td> <td>L2</td> </tr> <tr> <td>L3</td> <td>1</td> <td>3</td> <td>L2</td> <td>L3</td> </tr> </tbody> </table>	Current transf.	Terminals	8	2	L2	1	3	L1	L2	L3	1	3	L2	L3			
Current transf.	Terminals	8	2															
L2	1	3	L1	L2														
L3	1	3	L2	L3														

SINEAX DME 401 with RS 485 Interface

Programmable Multi-Transducer

Measuring inputs

System / application

Terminals

3-wire
3-phase
symmetric
load
Phase-shift
U: L2 - L3
I: L1

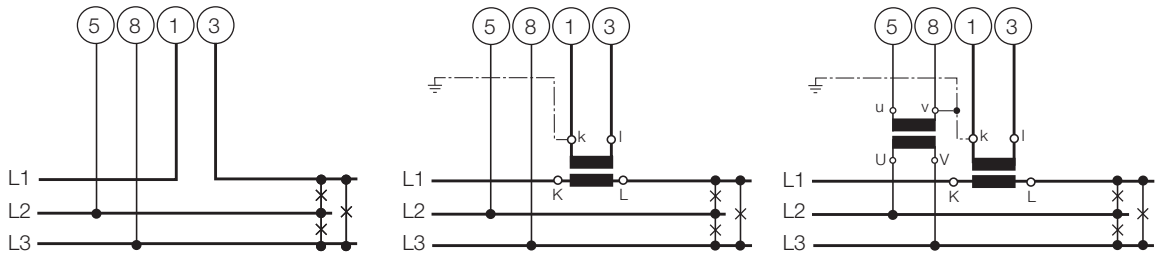

Connect the voltage according to the following table for current measurement in L2 or L3:

Current transf.	Terminals		5	8
L2	1	3	L3	L1
L3	1	3	L1	L2

4-wire
3-phase
symmetric
load
I: L1

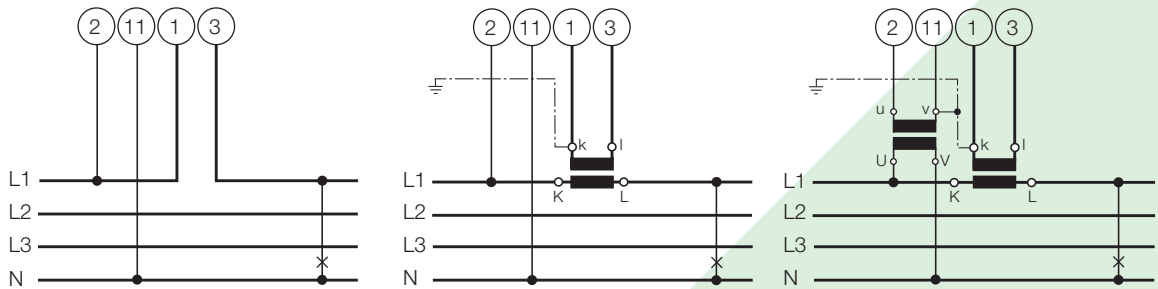

Connect the voltage according to the following table for current measurement in L2 or L3:

Current transf.	Terminals		2	11
L2	1	3	L2	N
L3	1	3	L3	N

3-wire
3-phase
asymmetric
load

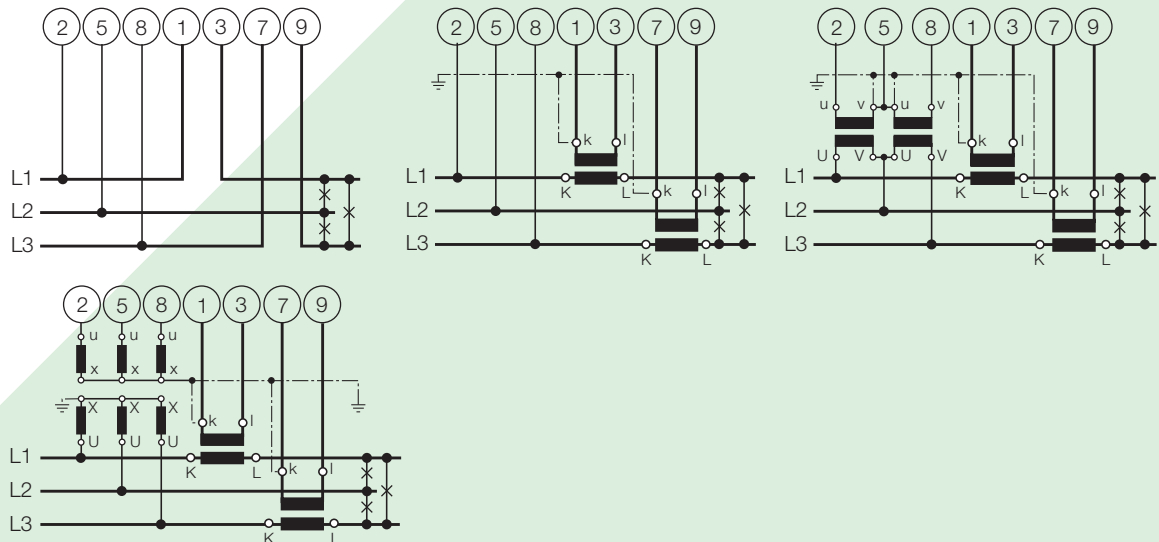

SINEAX DME 401 with RS 485 Interface Programmable Multi-Transducer

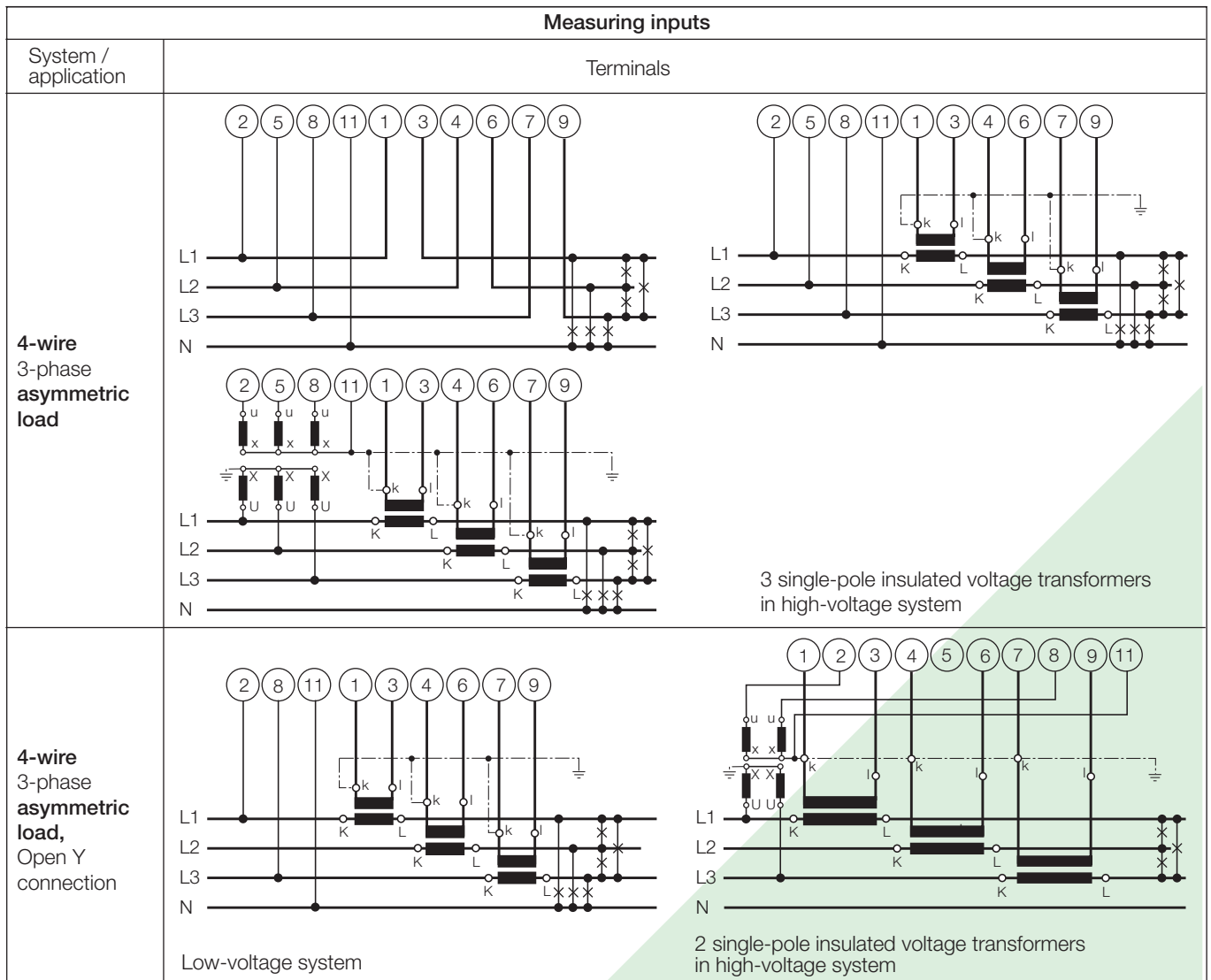

Relationship between PF, QF and LF

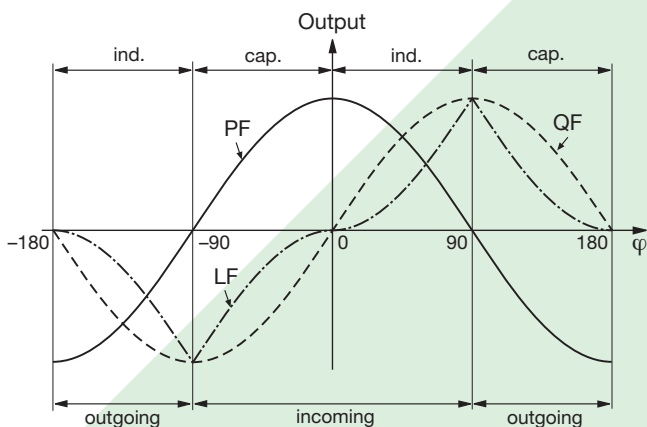

Fig. 3. Active power PF —, reactive power QF -----, power factor LF - - - -.

Connecting devices to the bus

The RS 485 interface of the DME 401 is galvanically isolated from all other circuits. For an optimal data transmission the devices are connected via a 3-wire cable, consisting of a twisted pair cable (for data lines) and a shield. There is no termination required. A shield both prevents the coupling of external noise to the bus and limits emissions from the bus. The shield must be connected to solid ground.

You can connect up to 32 members to the bus (including master). Basically devices of different manufacturers can be connected to the bus, if they use the standard MODBUS® protocol. Devices without galvanically isolated bus interface are not allowed to be connected to the shield.

The optimal topology for the bus is the daisy chain connection from node 1 to node 2 to node n. The bus must form a single continuous path, and the nodes in the middle of the bus must have short stubs. Longer stubs would have a negative impact on signal quality (reflection at the end). A star or even ring topology is not allowed.

There is no bus termination required due to low data rate. If you got problems when using long cables you can terminate the bus at both ends with the characteristic impedance of the cable

SINEAX DME 401 with RS 485 Interface

Programmable Multi-Transducer

(normally about 120 Ω). Interface converts RS232⇔RS485 or RS485 interface cards often have a built-in termination network which can be connected to the bus. The second impedance then can be connected directly between the bus terminals of the device far most.

Fig. 4 shows the connection of transducers DME 401 to the MODBUS. The RS 485 interface can be realized by means of PC built-in interface cards or interface converters. Both is shown using i.e. the interfaces 13601 and 86201 of W & T (Wiesemann & Theis GmbH). They are configured for a 2-wire application with automatic control of data direction. These interfaces provide a galvanic isolation and a built-in termination network.

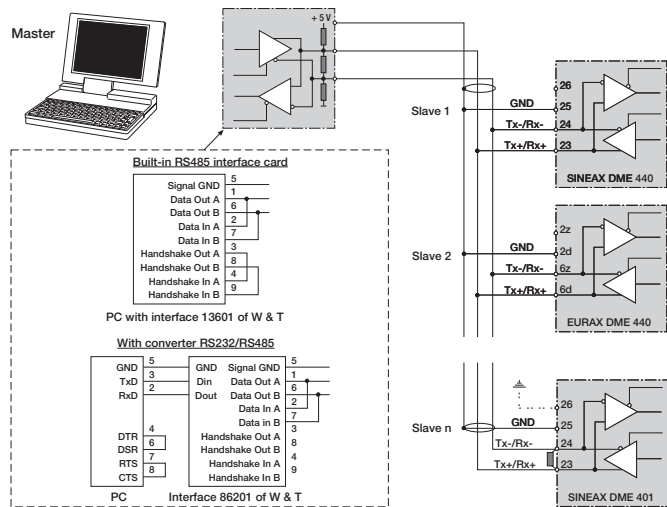

Fig. 4

Important:

- Each device connected to the bus must have a unique address
- All devices must be adjusted to the same baudrate.

Dimensioned drawings

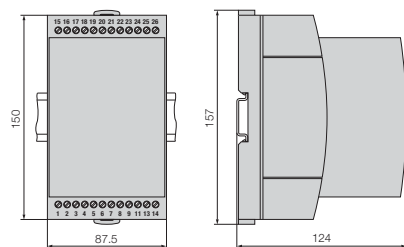

Fig. 5. SINEAX DME 401 in housing T24 clipped onto a top-hat rail (35 x 15 mm or 35x7.5 mm, acc. to EN 50 022).

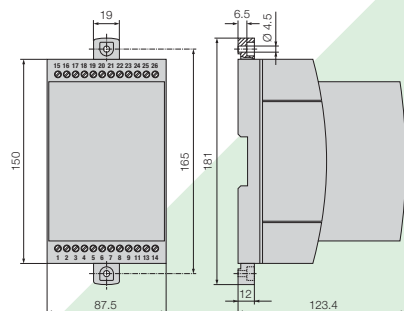

Fig. 6. SINEAX DME 401 in housing T24 screw hole mounting brackets pulled out.

Table 5: Accessories and spare parts

Description	Order No.
Programming cable	980 179
Configuration software DME 4 for SINEAX/EURAX DME 424, 440, 442, SINEAX DME 400, 401 and 406 Windows 3.1x, 95, 98, NT and 2000 on CD in German, English, French, Italian and dutch (Download free of charge under http://www.camillebauer.com) In addition, the CD contains all configuration programmes presently available for Camille Bauer products.	146 557
Operating Instructions DME 401-1 B d-f-e , in three languages: German, English and French	146 804



Description	Order No.
SINEAX A 200	154 063
Interconnecting cable sub D 9 pol. mal/male 1.8 m	154 071

CAMILLE BAUER

Rely on us.

Camille Bauer Ltd
Aargauerstrasse 7
CH-5610 Wohlen / Switzerland

Phone: +41 56 618 21 11

Fax: +41 56 618 35 35

e-Mail: info@camillebauer.com

www.camillebauer.com

Appendix: PROGRAMMING FOR SINEAX TYPE DME 401



without analog outputs, with RS 485 Interface (MODBUS®)
 (see Data Sheet DME 401-1 Le, Table 4: "Programming")

Customer / Agent: _____	Date: _____
Order No. / Item: _____	Delivery date: _____
No of instruments: _____	
Type of instruments (marking): _____	

Codes for features 1 to 8:

Features 1 to 8 concern data for configuring the software.

<table border="1" style="width: 100%; height: 20px;"> <tr> <td style="width: 20px; text-align: center;">A</td> <td style="width: 20px;"></td> <td style="width: 20px;"></td> <td style="width: 20px;"></td> </tr> </table>	A				1. Application System _____
A					
<table border="1" style="width: 100%; height: 20px;"> <tr> <td style="width: 20px; text-align: center;">U</td> <td style="width: 20px;"></td> <td style="width: 20px;"></td> <td style="width: 20px;"></td> </tr> </table>	U				2. Rated input voltage, rated value Ur = _____ V _____
U					
<table border="1" style="width: 100%; height: 20px;"> <tr> <td style="width: 20px; text-align: center;">V</td> <td style="width: 20px;"></td> </tr> </table>	V		3. Rated input current, rated value Ir = _____ A _____		
V					
<table border="1" style="width: 100%; height: 20px;"> <tr> <td style="width: 20px; text-align: center;">W</td> <td style="width: 20px;"></td> </tr> </table>	W		4. Primary rating VT = _____ kV CT = _____ A Specify transformer ratio primary, e.g.. 33 kV, 1000 A The secondary ratings must correspond to the rated input voltage and current specified for feature 2, respectively 3.		
W					
<table border="1" style="width: 100%; height: 20px;"> <tr> <td style="width: 20px; text-align: center;">E</td> <td style="width: 20px; text-align: center;">A</td> <td style="width: 20px;"></td> <td style="width: 20px;"></td> </tr> </table>	E	A			5. Energy meter 1
E	A				
<table border="1" style="width: 100%; height: 20px;"> <tr> <td style="width: 20px; text-align: center;">F</td> <td style="width: 20px; text-align: center;">A</td> <td style="width: 20px;"></td> <td style="width: 20px;"></td> </tr> </table>	F	A			6. Energy meter 2
F	A				
<table border="1" style="width: 100%; height: 20px;"> <tr> <td style="width: 20px; text-align: center;">G</td> <td style="width: 20px; text-align: center;">A</td> <td style="width: 20px;"></td> <td style="width: 20px;"></td> </tr> </table>	G	A			7. Energy meter 3
G	A				
<table border="1" style="width: 100%; height: 20px;"> <tr> <td style="width: 20px; text-align: center;">H</td> <td style="width: 20px; text-align: center;">A</td> <td style="width: 20px;"></td> <td style="width: 20px;"></td> </tr> </table>	H	A			8. Energy meter 4
H	A				