

# EURAX G 536

## Phase angle or power factor transducer

EURAX plug-in module in Euro format



### Application

The transducer **EURAX G 536** (Fig. 1) measures the phase angle or power factor between current and voltage of a single or 3-phase balanced network having a sine wave form.

The output signal, in the form of a **load independent** DC current or voltage, is proportional to the phase angle resp. power factor between the 2 measured quantities current and voltage.

The transducer fulfils all the important requirements and regulations concerning electromagnetic compatibility **EMV** and **Safety** (IEC 1010 resp. EN 61 010). It was developed and is manufactured and tested in strict accordance with the **quality assurance standard** ISO 9001.

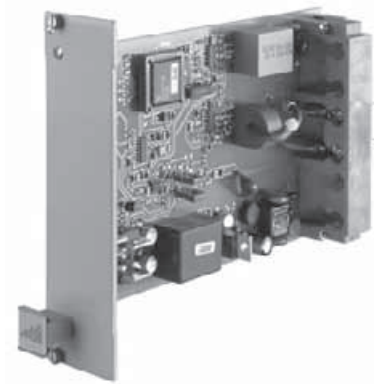

Fig. 1. EURAX G 536 as plug-in module for 19" rack-mounted case, front plate width 7 TE.

### Features / Benefits

- **Measuring input:** Sine, rectangular or distorted wave forms of input quantities with dominant fundamental waves

Measured variables	Nominal input current	Nominal input voltage	Measuring range limits
Phase angle or power factor	0.5 to 6 A	10 to 690 V	Min. span 20 °el Max. span 360 °el

- **Measuring output:** Unipolar, bipolar or live zero output variables
- **Measuring principle:** Measurement of the zero crossing interval
- **Wide DC, AC power pack tolerance / Universal**
- **Plug-in module (front plate width 7 TE) for 19" rack-mounted case / Ease of mounting in rack system**

### Technical data

#### General

Measured quantity: Phase angle or power factor between current and voltage

Measuring principle: Measurement of the zero crossing interval

#### Measuring input $\rightarrow$

Examples of measuring ranges with  $\varphi$ -linear output

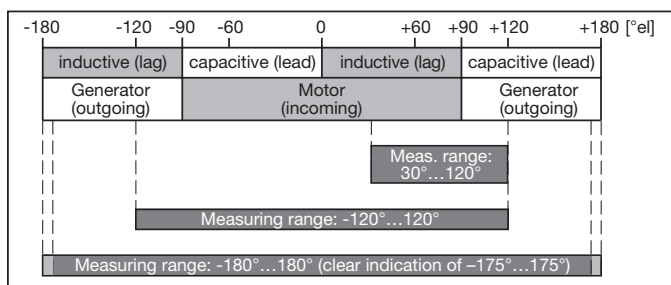

Examples of measuring ranges with  $\cos\varphi$ -linear output

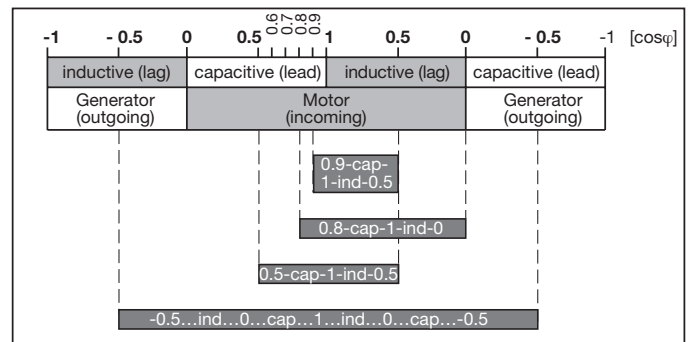

Nominal frequency  $f_N$ : 16 2/3 ... 400 Hz

Nominal input voltage  $U_N$ : 10 ... 690 V  
(max. 230 V with power supply from voltage measuring input)

Response sensitivity: 10 ... 120%  $U_N$

Nominal input current  $I_N$ :  $\geq 0.5$  to 6.0 A

Response sensitivity:  $< 1\% I_N$

Own consumption:  $< 0.1$  VA per current path  
 $U_N \cdot 1.5$  mA per voltage path

Overload capacity:

Input variables $I_N, U_N$	Number of applications	Duration of one application	Interval between two successive applications
$1.2 \times I_N$	---	continuously	---
$20 \times I_N$	10	1 s	100 s
$1.2 \times U_N^1$	---	continuously	---
$2 \times U_N^1$	10	1 s	10 s

<sup>1</sup> But max. 264 V with power supply from voltage measurement

# EURAX G 536

## Phase angle or power factor transducer

### Measuring output

Load-independent DC current:	0 ... 1 to 0 ... 20 mA resp. live-zero 0.2 ... 1 to 4 ... 20 mA $\pm 1$ to $\pm 20$ mA
Burden voltage:	+ 15 V, resp. - 12 V
Load-independent DC voltage:	0 ... 1 to 0 ... 10 V resp. live-zero 0.2 ... 1 to 2 ... 10 V $\pm 1$ to $\pm 10$ V
Load capacity:	Max. 4 mA
Voltage limit under $R_{ext} = \infty$ :	$\leq 25$ V
Current limit under overload:	Approx. 30 mA
Residual ripple in output current:	$< 0.5\%$ p.p.
Nominal value of response time:	4 periods of the nominal frequency
Other ranges:	2, 8 or 16 periods of the nominal frequency

### Output characteristic

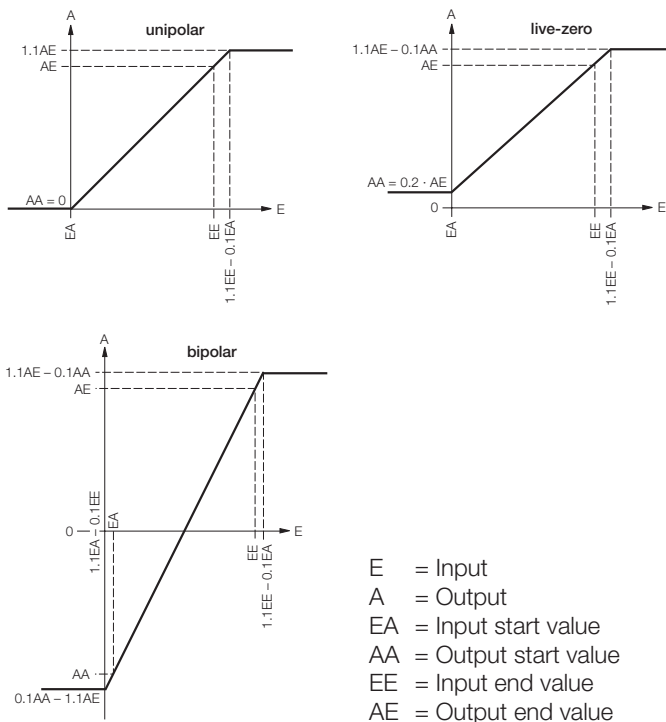

### Accuracy (acc. to IEC 688)

Reference value:	$\Delta\varphi = 90^\circ$ resp. $\Delta \cos\varphi = 0.5$
Basic accuracy:	Class 0.5

### Reference conditions:

Ambient temperature	15 ... 30 °C
Input current	0.8 ... 1.2 $I_N$
Input voltage	0.8 ... 1.2 $U_N$
Frequency	$f_N \pm 10\%$
Wave forms	Sine wave
Power supply	At nominal range
Output burden	$\Delta R_{ext}$ max.

### Additional errors (maxima):

Voltage influence between 0.5 and 1.5 $U_N$	$\pm 0.3\%$
Current influence	
– between 0.4 and 1.5 $I_N$	$\pm 0.3\%$
– between 0.1 and 1.5 $I_N$	$\pm 0.5\%$

### Safety

Protection class:	II (protection isolated, EN 61 010)
Pollution degree:	2
Installation category:	III
Rated insulation voltage (against earth):	230 V resp. 400 V, inputs 230 V, power supply 40 V, output
Test voltage:	50 Hz, 1 min. acc. to EN 61 010-1 3700 resp. 5550 V, inputs versus all other circuits 3250 V, input circuits versus each other 3700 V, power supply versus output

### Power supply

DC, AC power pack (DC or 40 ... 400 Hz)

Table 1: Rated voltages and permissible variations

Rated voltage	Tolerance
85 ... 230 V DC, AC	DC - 15 ... + 33% AC $\pm 15\%$
24 ... 60 V DC, AC	

or

Power supply from voltage measuring input:	24 ... 60 V AC or 85 ... 230 V AC
Power consumption:	Approx. 2 W resp. 4 VA

### Installation data

Mechanical design:	Plug-in module for 19" rack-mounted case, Euro format 100 x 160 mm
Space requirements:	7 TE (35.26 mm) (see section "Dimensional drawing")
Front plate colour:	Grey RAL 7032

Designation:	EURAX G 536	<b>Ambient tests</b>	
Mounting position:	Any	En 60 068-2-6:	Vibration
Electrical connections:	32-pole plug acc. to DIN 41 612, pattern F and 2-pole current plug Contact fitting see section "Electrical connections"	Acceleration:	± 2 g
		Frequency range:	10 ... 150 ... 10 Hz, rate of frequency sweep: 1 octave / minute
Coding:	By coding pins, removed / not re- moved, see section "Electrical con- nections"	Number of cycles:	10, in each of the three axes
		EN 60 068-2-27:	Shock
Weight:	Approx. 0.24 kg	Acceleration:	3 × 50 g, 3 shocks each in 6 directions
		EN 60 068-2-1/-2/-3:	Cold, dry heat, damp heat

**Environmental conditions**

Operating temperature:	- 10 to +55 °C
Storage temperature:	- 40 to +70 °C
Relative humidity of annual mean:	≤ 75%

**Table 2: Specification and ordering information**

Order Code 536 -						
Features, Selection	*SCODE	no-go	1	2	3	4
<b>1. Mechanical design</b> 2) Plug-in module for 19" rack-mounted case			2	.	.	.
<b>2. Measuring mode</b> 1) For phase angle ( $\varphi$ -linear) 2) For power factor ( $\cos\varphi$ -linear)	A B		.	1	.	.
<b>3. Application</b> 1) Single-phase AC 2) U: L1 & L2 I: L1 3 or 4-wire 3-phase balanced load 3) U: L2 & L3 I: L2 3 or 4-wire 3-phase balanced load 4) U: L3 & L1 I: L3 3 or 4-wire 3-phase balanced load 5) U: L1 & L3 I: L1 3 or 4-wire 3-phase balanced load 6) U: L2 & L1 I: L2 3 or 4-wire 3-phase balanced load 7) U: L3 & L2 I: L3 3 or 4-wire 3-phase balanced load A) U: L1 & L2 I: L3 3 or 4-wire 3-phase balanced load B) U: L2 & L3 I: L1 3 or 4-wire 3-phase balanced load C) U: L3 & L1 I: L2 3 or 4-wire 3-phase balanced load			.	.	1	
<b>4. Nominal input frequency</b> 1) 50 Hz 2) 60 Hz 9) Non-standard [Hz] <span style="background-color: #cccccc;">          </span> ≥ 10 to 400 Hz With power supply from measuring input min. 40 Hz			.	.	.	1
			.	.	.	2
			.	.	.	9

Continuation of "Table 2: Specification and ordering information" see on next page!

# EURAX G 536

## Phase angle or power factor transducer

Continuation of "Table 2: Specification and ordering information"!

Order Code 536 -			↑ ↑ ↑ ↑ ↑
Features, Selection	*SCODE	no-go	
<b>5. Nominal input voltage</b>			
1) $U_N = 100$ V	C		1 . . . . .
2) $U_N = 230$ V	C		2 . . . . .
3) $U_N = 400$ V	D		3 . . . . .
9) Non-standard [V] <input type="text"/>			9 . . . . .
$\geq 10$ to 690			
With power supply from measuring input min. 24 V, max. 230 V, see feature 9, lines 3 and 4			
3 phase system: Input voltage = phase to phase voltage			
<b>6. Nominal input current</b>			
1) 1 A			. 1 . . . . .
2) 5 A			. 2 . . . . .
9) Non-standard [A] <input type="text"/>			. 9 . . . . .
$\geq 0.5$ to 6.0			
<b>7. Measuring range</b>			
1) Phase angle $-60 \dots 0 \dots +60$ °el		B	. . 1 . . . . .
2) $\cos\varphi$ 0,5 ... cap ... 1 ... ind ... 0,5		A	. . 2 . . . . .
9) Non-standard [°el] or [cosφ] <input type="text"/>			. . 9 . . . . .
Measuring range within $-180 \dots 0 \dots +180$ °el or $-1 \dots \text{ind} \dots 0 \dots \text{cap} \dots 1 \dots \text{ind} \dots 0 \dots \text{cap} \dots -1$ , but clear indication only to $-175 \dots 0 \dots +175$ °el Measuring span $\geq 20$ °el			
<b>8. Output signal</b>			
1) 0 ... 20 mA			. . . 1 . . . . .
2) 4 ... 20 mA			. . . 2 . . . . .
9) Non-standard [mA] <input type="text"/>			. . . 9 . . . . .
0 ... 1.00 to 0 ... < 20, -1.00 ... 0 ... 1.00 to -20 ... 0 ... 20 (symmetrical) 0.2 ... 1 to < (4 ... 20) (AA / AE = 1 / 5)			
A) 0 ... 10 V			. . . A . . . . .
Z) Non-standard [V] <input type="text"/>			. . . Z . . . . .
0 ... 1.00 to 0 ... < 10, -1.00 ... 0 ... 1.00 to -10 ... 0 ... 10 (symmetrical) 0.2 ... 1 to 2 ... 10 (AA / AE = 1 / 5)			
AA = Output start value, AE = Output end value			
<b>9. Power supply</b>			
1) 85 ... 230 V DC, AC			. . . . 1 . . . .
2) 24 ... 60 V DC, AC			. . . . 2 . . . .
3) Internal from measuring input (24 ... 60 V AC)		CD	. . . . 3 . . . .
4) Internal from measuring input (85 ... 230 V AC)		D	. . . . 4 . . . .

Continuation of "Table 2: Specification and ordering information" see on next page!



# EURAX G 536

## Phase angle or power factor transducer

### Electrical connections

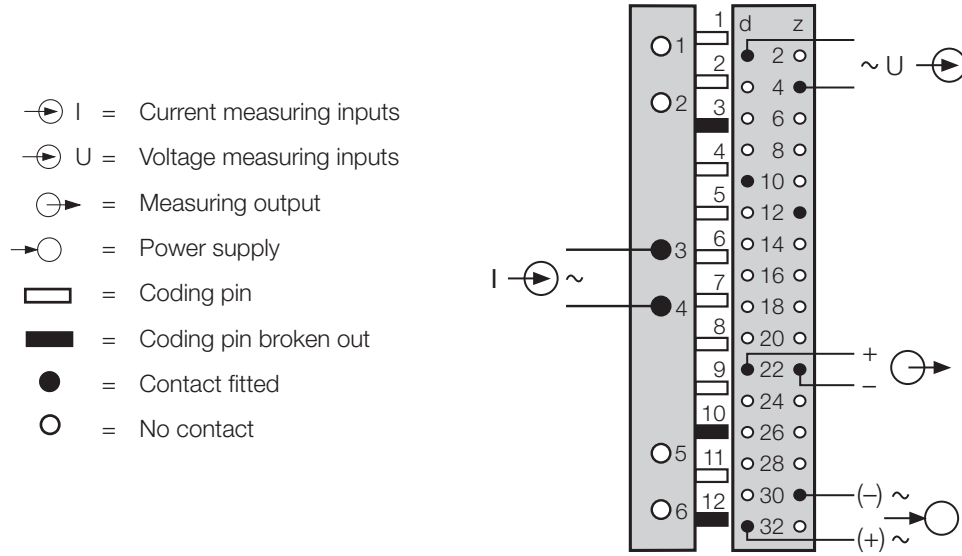

### Measuring inputs

Application	Plug wiring	Application	Plug wiring
Phase angle or power factor measurement in single-phase AC network		Phase angle or power factor measurement in 3 or 4-wire 3-phase network U: L1 & L2 I: L1	
Phase angle or power factor measurement in 3 or 4-wire 3-phase network U: L2 & L3 I: L2		Phase angle or power factor measurement in 3 or 4-wire 3-phase network U: L3 & L1 I: L3	
Phase angle or power factor measurement in 3 or 4-wire 3-phase network U: L1 & L3 I: L1		Phase angle or power factor measurement in 3 or 4-wire 3-phase network U: L2 & L1 I: L2	
Phase angle or power factor measurement in 3 or 4-wire 3-phase network U: L3 & L2 I: L3		Phase angle or power factor measurement in 3 or 4-wire 3-phase network U: L1 & L2 I: L3	
Phase angle or power factor measurement in 3 or 4-wire 3-phase network U: L2 & L3 I: L1		Phase angle or power factor measurement in 3 or 4-wire 3-phase network U: L3 & L1 I: L2	

## Dimensional drawing

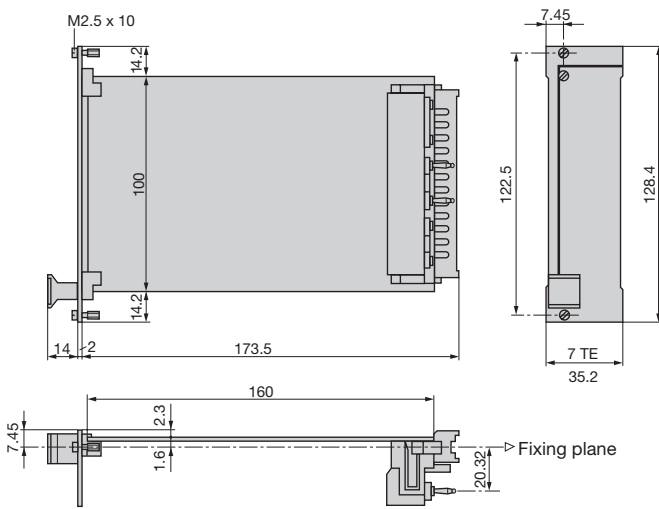

Fig. 2. EURAX G 536, front plate width 7 TE.

# EURAX G 536

## Phase angle or power factor transducer

---

---

Printed in Switzerland • Subject to change without notice • Edition 08.01 • Data sheet No. G 536-2 Le

Aargauerstrasse 7  
CH-5610 Wohlen/Switzerland  
Phone +41 56 618 21 11  
Fax +41 56 618 24 58  
e-mail: [cbag@gmc-instruments.com](mailto:cbag@gmc-instruments.com)  
<http://www.gmc-instruments.com>

Camille Bauer Ltd

GOSSEN  
METRAWATT  
CAMILLE BAUER 