

LSP-KONSTANTER Series 32K

Laboratory Power Supply

3-349-285-15

6/11.08



Programmable Power Supply

LSP-KONSTANTER Series 32K Operating Instructions

Table of Contents

Safety Precautions, Warning Symbols	3
Caution.....	4
I Safety Precautions.....	4
II Connecting the Power Cable	4
III Fuse	5
IV Power Supply Output Terminals	5
1 Introduction.....	6
1.1 Description	6
1.2 Technical Data	6
1.3 Features	7
1.4 Dimensions and Mechanical Layout	7
1.4.1 Dimensions	7
1.4.2 Mechanical Layout.....	8
1.4.2.1 Front Panel.....	8
1.4.2.2 Rear Panel.....	9
2 Operation.....	10
2.1 General Operation.....	10
2.2 Introduction to Device Functions.....	10
2.2.1 Main Functions.....	10
2.2.2 Sub-Functions (menu functions).....	10
2.3 Using Device Functions	10
2.3.1 V-set (select a constant voltage between 0 and U_{max})	10
2.3.2 I-set (select a constant current or a maximum current value between 0 and I_{max}).....	12
2.3.3 Switching the Power Output On and Off.....	12
2.3.4 Data Storage.....	13
2.3.5 Data Recall.....	13
2.3.6 Menu Functions	14
2.3.6.1 Maximum Allowable Output Voltage	14
2.3.6.1 Maximum Allowable Output Power	14
2.3.6.3 Enabling and Disabling the Rotary Switch	15
2.3.6.4 Output Status after Power-Up – Initial OUT SET	15
2.3.6.5 Save Momentary Voltage Value – Voltage Save Set.....	15
2.3.6.6 Transmission Speed Setting	15
2.3.6.7 Selecting a Communication Address	16
2.3.6.8 Disabling the Keypad	16
2.3.6.9 Deleting Saved Data Records.....	16
2.3.6.10 Exit Function	16
Repair and Replacement Parts Service DKD Calibration Center* and Rental Instrument Service.....	17
Competent Partner	17
Product Support	17

Safety Precautions, Warning Symbols

These operating instructions include all necessary safety precautions for personal safety, as well as for preventing damage to the power supply and any devices connected to it. Precautions are identified with a warning triangle, and are designated as follows depending upon the degree of danger:



Danger

Noncompliance with safety precautions identified with the word danger results in personal injury, death or severe property damage.



Caution

Noncompliance with safety precautions identified with the word caution results in personal injury or property damage.



Note

Texts identified with the word note draw the user's attention to important product information, information regarding the disposal of old devices or specific passages within the documentation.



Warning

Only trained personnel are permitted to inspect and operate this device. Trained personnel are defined as persons who have been instructed in initial start-up and grounding of the device, as well as concerning regulations included in the applicable safety precautions and standards.



Use for Intended Purpose, Attention

Note

Device functions can only be executed flawlessly and reliably if the device has been properly transported, stored, set up and installed.



Caution

The following general safety precautions must always be adhered to during operation, maintenance and repair of the device. Noncompliance with these safety precautions, or with other explicit warnings included in these operating instructions, is deemed a violation of design-specific safety standards and use for intended purpose. The manufacturer assumes no liability in the event of noncompliance with these safety precautions.

I Safety Precautions

- 1 The device may only be operated in accordance with the procedures included in these operation instructions.
- 2 High-voltage conducting components are located inside the device, which may not be contacted directly.
- 3 Read the operating instructions carefully before placing the instrument into service, in order to assure your own safety.
- 4 The device must be grounded.

The device is equipped with a protective earth terminal. The device chassis and the housing must be grounded in order to eliminate the danger of electrical shock. The device may only be connected to mains power by means of a 3 conductor cable, and the protective conductor must be securely connected to the protective conductor terminal of the mains outlet.

- 5 Keep away from voltage conducting electrical circuits!

Operating personnel may not remove any of the device's covers. Only trained personnel are permitted to replace components and change internal settings. Components may not be touched as long as the power cable is connected.

Dangerous voltage may be present even after the power cable has been disconnected from the mains. The device must be disconnected from the mains, electrical circuits must be discharged and external voltage sources must be disconnected before touching any components, in order to prevent personal injury.

The device may not be modified, and only original replacement parts may be used.

Due to the fact that additional danger may otherwise occur, only original replacement parts may be used and the device may not be modified in an unauthorized fashion. In order to assure uninterrupted functionality of the device's safety features, it may only be maintained and/or repaired by qualified service providers.

II Connecting the Power Cable

- 1 Examine the voltage selector switch on the back of the device in order to assure that the selected voltage coincides with available mains power. If this is not the case, observe the note printed on the device's mains inlet plug, and make sure that the correct fuse is utilized.
- 2 The on/off switch in the device's front panel must be switched off before the power supply is connected to the mains.
- 3 Connect the 3 conductor cable with plug to the mains outlet. The device must be connected to the protective earth conductor.
- 4 Press the switch on the front panel in order to turn the device on. The device is now ready for operation.

III Fuse

- 1 The fuse is located in proximity to the mains power inlet plug on the back of the device. Observe the following points if input voltage is changed and/or the fuse is replaced:
- 2 The on/off switch must be turned off and the power supply must be disconnected from all other devices before changing input voltage and/or replacing the fuse.
- 3 Press the fuse holder with a screwdriver and the fuse pops out.
- 4 Pull the fuse out and replace it with a new fuse which complies with the specifications on the label next to the mains power inlet plug.

Warning: Use approved fuse types only in order to prevent damage to the device.

- 5 If input voltage needs to be changed, replace the fuse as described above and then set the voltage selector switch to the desired position (220 V AC or 110 V AC). The selected input voltage appears at the selector switch.

IV Power Supply Output Terminals

- 1 For reasons of safety, make sure that there are no short-circuits between the positive and negative terminals. The device is equipped with short-circuit protection, but a short-circuit may result in injury to the user.
- 2 The output cable must be insulated all the way up to the connected power consumer.
- 3 The power supply should be switched on 30 minutes before the power consumer is used.

Operating Instructions for LSP-KONSTANTER Series 32K

1 Introduction

1.1 Description

Series 32K LSP-KONSTANTERs are compact programmable DC power supplies featuring an attractive design. They are equipped with a backlit LCD, a numeric keypad and a rotary switch for easy operation. Voltage, current and power can be plainly displayed at the LCD. The device includes two control modes: the constant voltage regulating mode (CV) and the constant current regulating mode (CC) with warning signal for exceeded maximum power value. Maximum values can be selected for output voltage, output current and power. The device is indispensable for research, training, maintenance etc.

1.2 Technical Data

Order Number	K110A	K111A	K112A
Type	32K 18R5	32K 36R3	32K 72R1.5
Outputs	1	1	1
Output voltage	0 ... 18 V	0 ... 36 V	0 ... 72 V
Output current	0 ... 5 A	0 ... 3 A	0 ... 1.5 A
Output power (max.)	90 W	108 W	108 W
Setting resolution	1 mV at 0 ... 3.999 V 10 mV as of 4.00 V	1 mV at 0 ... 3.999 V 10 mV as of 4.00 V	1 mV at 0 ... 3.999 V 20 mV as of 4.00 V
Voltage	1 mA		
Current	1 mA		
Setting accuracy at 25 °C ± 5 °C	0.1% + 20 mV	0.1% + 20 mV	0.1% + 20 mV
Voltage	0.2% + 20 mA		
Current	0.2% + 20 mA		
Mains correction	0 ... 3.999 V 4 V ... U _{max}	0.01% +3 mV 0.02% +10 mV	
Voltage	0.02% +8 mA		
Current	0.02% +8 mA		
Load correction			
Voltage	0.02% +20 mV	0.02% +10 mV	0.02% +10 mV
Current	0.02% +15 mA	0.02% +10 mA	0.02% +8 mA
Residual ripple			
Voltage	< 1 mV rms	< 1 mV rms	< 1 mV rms
Current	< 5 mA rms	< 4 mA rms	< 3 mA rms
Protective functions	Overvoltage (setting limit), overcurrent (current regulation), overpower (alarm signal)		
Measuring resolution			
Voltage	10 mV	10 mV: 0 ... 19.99 V 100 mV as of 20 V	10 mV: 0 ... 19.99 V 100 mV as of 20 V
Current	10 mA		
Measuring Accuracy at 25 °C ± 5 °C	0.2% + 20 mV	0.2% + 20 mV, < 20V 0.2% + 100 mV, >20V	0.2% + 20 mV, < 20V 0.2% + 100 mV, > 20V
Voltage	0.2% + 20 mA		
Current	0.2% + 20 mA		
Memory	10 data records (EEPROM)		
Power supply	115 / 230 V AC + 10% / -15%, 47 ... 63 Hz		
Mains fuse	115 V AC	T 6.3 A	
	230 V AC	T 3.15 A	
Measuring category (overvoltage category)	250 V, CAT II		
Ambient conditions	0 ... 50 °C 80% relative humidity		
Weight	6.00 kg		
Dimensions	W x H x D 212.6 x 88.1 x 250 mm		
Accessories	Operating instructions, power cable, handles		
Optional accessories (in preparation)	RS 232 communication cable RS 485 communication cable Operating software Installation kit for 19" rack		

1.3 Features

- 1 LCD with background illumination
- 2 Numeric keypad
- 3 High resolution: 1 mV within a range of up to 4 V, otherwise 10 mV
- 4 Overvoltage protection (soft limit)
- 5 Overcurrent protection (current regulation)
- 6 Adjustable voltage and constant voltage regulating mode (CV)
- 7 Adjustable current and constant current regulating mode (CC)
- 8 Adjustable maximum current limit value (CC)
- 9 Adjustment with numeric keypad or rotary switch
- 10 Momentary voltage value is saved to memory when the device is switched off
- 11 Operation by means of PC software (optional accessory)
- 12 Compact, portable and lightweight
- 13 Can be connected in series or parallel

1.4 Dimensions and Mechanical Layout

1.4.1 Dimensions

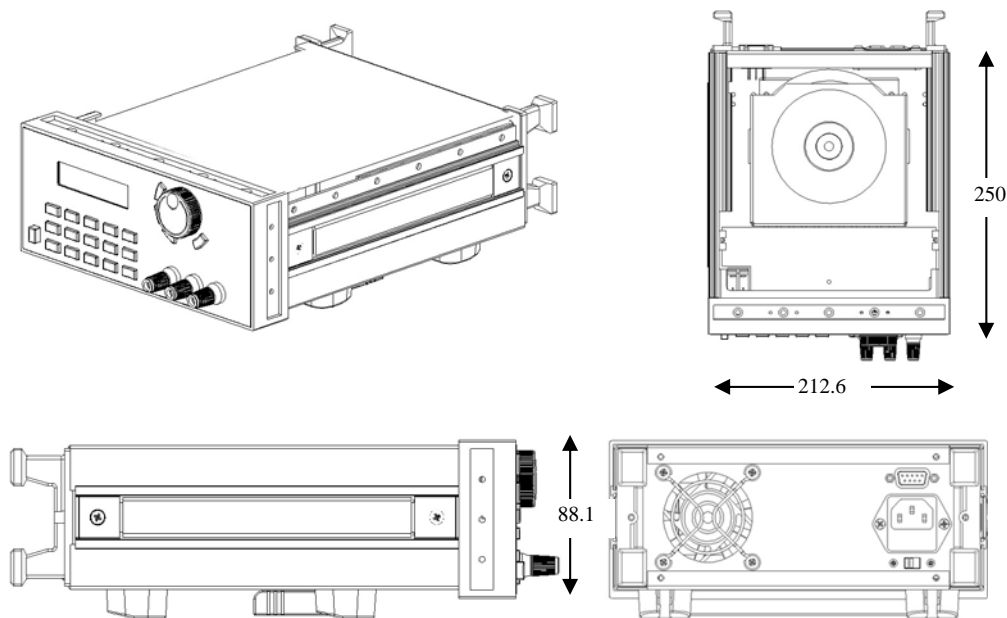

Figure 1: Dimensions, LSP-KONSTANTER Series 32K

1.4.2 Mechanical Layout

1.4.2.1 Front Panel

The device is operated at the front panel. See figure 2 and detail views.

- 1 LCD panel
- 2 Numeric keypad
- 3 Rotary switch
- 4 Output jacks
- 5 Mains switch



Figure 2: Front View

1 LCD panel



Figure 3: LCD Panel

Bottom left: Output power

Bottom center: Output operating state
 ON (OFF): The output is on (off)
 OP: Load exceeds max. power (additional acoustic signal)

Top left: Voltage setpoint or momentary voltage value

(The voltage setpoint is displayed during voltage setting. If no adjustments are made for approximately 5 seconds, the display returns to the momentary output voltage value without cursor.)

Top right: Momentary output current value

Bottom right: CC (control mode): The output is in the constant current regulating mode.

Bottom far right: PC: Operation via PC

2. Keypad Layout



Figure 4: Keypad

In the setting mode, the keys execute the input prompts which are printed in black.
 In the special mode, they execute the input prompts which are printed in blue.

- 0 ... 9:** Numeric keys
- Store:** Save selected setting values
- Recall:** Read out selected setting values
- Menu:** Key for menu-driven operation
- Out on/off:** Switches the output on and off
- Enter:** Acknowledgement key
- V-set:** Set output voltage
- I-set:** Set output current
- ▲:** Scroll up through menu functions
- ▼:** Scroll down through menu functions
- V/A:** V applies when setting output voltage in volts
 A applies when setting output current in amperes
- mV/mA:** mV applies when setting output voltage in millivolts
 mA applies when setting output current in milliamperes

3. Rotary Switch with Function Keys



Rotary switch: Adjusting knob for selecting the cursor position, or for use in the operating menu

Arrow, left: Moves the cursor to the left

Arrow, right: Moves the cursor to the right

ESC: Can be pressed to exit any function

OK: Acknowledgement key

Figure 5: Rotary Switch with Function Keys

1.4.2.2 Rear Panel



Figure 6: Rear View

The fuse can be easily replaced with the help of a screwdriver. Utilized fuses must comply with the specifications printed on the device (230 / 115 V AC).

2 Operation

2.1 General Operation

Connect the power supply to mains power in accordance with section II above. The device is now ready for operation. The KONSTANTER can now be switched on with the mains switch at the front panel (item 5, fig. 2, section 1.4.2).

Default settings have been set up such that the output is deactivated (OUTPUT OFF). The controls are enabled for the entry of settings and no password is required.

2.2 Introduction to Device Functions

2.2.1 Main Functions

- 1 Select a constant voltage between 0 and U_{max}
- 2 Select a constant current or a maximum current value between 0 and I_{max}
- 3 Switch the power output on or off
- 4 Save defined data records (max. 10)
- 5 Recall saved data

2.2.2 Sub-Functions (menu functions)

- | | | |
|----|---|-----------------|
| 1 | Select limit value for maximum output voltage | MAX VOLTAGE SET |
| 2 | Set monitoring for maximum output power | MAX POWER SET |
| 3 | Enable/disable rotary switch function | ROTARY SW SET |
| 4 | Select initial output status after power-up | INITIAL OUT SET |
| 5 | Save last valid V-set value | VOLT. SAVE SET |
| 6 | Set transmission speed (baud rate) | BAUDRATE SET |
| 7 | Select the communication address | ADDRESS SET |
| 8 | Disable or enable the keypad | KEY LOCK |
| 9 | Delete stored data | CLEAR SAVE DATA |
| 10 | Exit the menu function | EXIT |

2.3 Using Device Functions

Use of the 5 main functions and the 10 sub-functions listed above is described in the following sections. Before the device can be used, the power cable must be connected and the mains switch must be turned on, after which the power-on indicator lamp lights up.

2.3.1 V-set (select a constant voltage between 0 and U_{max})

The selection of a constant output voltage is the first main function of the programmable DC power supply. A constant output voltage can be selected in two ways for the LSP-KONSTANTER series 32K device: → with the numeric keypad or with the rotary switch.

Output voltage is subdivided into two ranges with different setting resolutions. The 0 to 4 V range has a setting resolution of 1 mV. At values of greater than 4 V, voltage is set with a resolution of 10 mV. The output is switched off briefly (deactivated) when the transition is made from one range to the next, i.e. from 4.999 to 5.00 V.

Use the following procedure for selecting the desired value.

Procedure:	Operation	Display
Step 1	Press the "V-set" key.	Input PASSWORD
Step 2	Enter the password, or jump down to step 4 if the keypad is already enabled.	Input PASSWORD
Step 3	Press the "OK" key (the display returns to step 2 if the password is entered incorrectly).	Input PASSWORD ****
Step 4	Press the "V-set" key. Set the voltage value to 24.00 with the help of the numeric keypad.	SET VOLT= momentary V value NEW =

Operating Instructions for LSP-KONSTANTER Series 32K

Step 5	Press the "V/A" key to acknowledge the selected setpoint. Selection is made with unit of measure V. Press the "mV/mA" key to change the unit of measure to mV. (The display returns to step 4 if the selected voltage value exceeds the upper voltage limit value and the maximum allowable value – Vmax. – is displayed).	SET VOLT= 24.00V NEW = 18
Step 4 Rotary switch	Press the "V-set" key. Activate the rotary switch with a slight jerk. The momentary value appears next to NEW (observe cursor position). Select the new value with the rotary switch.	SET VOLT= momentary V value NEW = momentary value
Step 5	Press the "V/A" or the "mV/mA" key in order to acknowledge the selected value in the displayed unit of measure.	SET VOLT= 24.00V NEW = 18.00
The voltage setting function can be exited at any time by pressing the ESC key.		

Example: set output voltage to 24.3 V

1 With the Numeric Keypad

- Step 1: Press the "V-set" key.
- Step 2: Enter the password with the keypad (jump down to step 4 if the keypad is already enabled).
- Step 3: Press the "OK" key (repeat step 2 if an incorrect password is entered).
- Step 4: Press the "2", "4", "." and "3" keys in order to enter the voltage value.
- Step 5: Press the "V/A" key to acknowledge the voltage value (in V).
The LCD returns to the display shown in figure 3.

2 With the Rotary Switch

- 1) Direct Selection:
If the keypad has already been enabled with the password, turn the rotary switch. Depending upon the direction of rotation, the voltage value at the currently selected cursor position is continuously increased or decreased. At first, the cursor appears at the last digit of the value displayed at the LCD. The cursor can be moved to the other digits with the "◀" and "▶" keys. The rotary switch is turned with the cursor positioned at each digit until a value of 24.3 has been selected. The output is immediately set to the selected value.
- 2) Selection via the Vset Menu
If the keypad is disabled:
 - Step 1: Press the "V-set" key.
 - Step 2: Enter the password with the numeric keypad.
 - Step 3: Press the "OK" key (repeat step 2 if an incorrect password is entered).
 - Step 4: Turn the rotary switch in order to change the value (same procedure as described above in point 1).
 - Step 5: Press the "V/A" or the "mV/mA" key to acknowledge the voltage value.

2.3.2 I-set (select a constant current or a maximum current value between 0 and I_{max})

A constant current or a maximum current from 0 to I_{max} can be selected for the LSP-KONSTANTER series 32K power supply. Depending upon the selected voltage and current values, as well as connected load, the device is operated in the voltage regulating mode (constant voltage) or the current regulating mode (constant current). Transition from one to the other is automatic (see the following example).

Given: voltage = 24 V, load R = 12 Ω, thus V/R = 2 A: The power supply provides the consumer with a current of 2 A.

- 1) If I-set is set to 2.50 A, a load current value of 2.00 A is displayed. The KONSTANTER is now operated in the voltage regulating mode. If load resistance is reduced, the current value increases. When output current has reached a value of 2.5 A, the power supply is switched to the current regulating mode, i.e. 2.5 A is the maximum current value.
- 2) If I-set is set to a value of 1.00 A, a current value of 1.00 A is displayed. This means that the power supply delivers a constant current of 1.00 A to the consumer (current regulating mode). With a load of 12 Ω, voltage amounts to 12 V.

The current value is set as follows:

Procedure:	Operation	Display
Step 1	Press the "I-set" key.	Input PASSWORD
Step 2	Enter the password, or jump down to step 4 if the keypad is already enabled.	Input PASSWORD
Step 3	Press the "OK" key (the display returns to step 2 if the password is entered incorrectly).	Input PASSWORD ****
Step 4	Press the "I-set" key. Select a constant current or a maximum current value with the numeric keypad or the rotary switch.	SET CURR = 0 A NEW = 3
Step 5	Press the "V/A" key to acknowledge the selected setpoint. Selection is made with unit of measure A. Press the "mV/mA" key to change the unit of measure to mA. (The display returns to step 4 if the selected current value exceeds upper current limit value I _{max} , and the maximum allowable value is displayed).	SET CURR = momentary A value NEW = 1.5
Step 4 Rotary switch	Press the "I-set" key. Select a constant current or a maximum current value with the rotary switch.	SET CURR = momentary A value NEW = momentary value
Step 5	Press the "V/A" or the "mV/mA" key in order to acknowledge the selected value in the displayed unit of measure.	SET CURR = momentary A value NEW = 0.05
The current setting function can be exited at any time by pressing the ESC key.		

2.3.3 Switching the Power Output On and Off

The output status of the LSP-KONSTANTER can be changed with the on/off switch. If the output is active, it can be switched off by pressing the on/off key. If the output has been deactivated, it can be switched on by pressing the on/off key.

Caution:

The output can be switched on and off even if the keypad is disabled with a password.

The output is not effected by keypad disabling.

2.3.4 Data Storage

This function facilitates device handling. In the event that you repeatedly require the same constant voltage and current values, for example 24 V and 2 A or 12 V and 2.3 A, the necessary settings only need to be entered once. Values can be saved to the power supply's memory module and recalled at any time as required. Up to 10 data records can be stored.

Each data record consists of the following four values: voltage, current, maximum voltage and maximum power.

After the values have been set as desired, they can be saved to memory as follows.

Procedure:	Operation	Display
Step 1	Press the "Store" key.	Input PASSWORD
Step 2	Enter the password, or jump down to step 4 if the keypad is already enabled.	Input PASSWORD
Step 3	Press the "OK" key (the display returns to step 2 if the password is entered incorrectly).	Input PASSWORD e.g. 1234
Step 4	Enter a data record number (1 to 10) with the help of the corresponding keys, or by turning the rotary switch.	SAVE <u>1</u>
Step 5	Press the "ENTER" or the "OK" key in order to save the data record number. If the entered number does not lie within a range of 1 to 10, the display returns to step 2.	SAVE *
The memory function can be exited at any time by pressing the ESC key.		

Example: Set voltage to 15 V, current to 2 A, max. output voltage to 18 V and max. output power to 25 W. All selected values can then be saved to memory with a data record number within a range of 01 to 10.

2.3.5 Data Recall

Up to 10 data records can be saved to memory using the procedure described in the previous section. These data records can be recalled from memory as required, thus significantly simplifying device operation. Previously saved settings no longer need to be reentered. One data record with the following four values can be recalled: voltage, current, maximum voltage and maximum power.

Data records are recalled as follows.

Procedure:	Operation	Display
Step 1	Press the "Recall" key.	CALL 1
Step 2	Enter the password, or jump down to step 4 if the keypad is already enabled.	Input PASSWORD
Step 3	Press the "OK" key (the display returns to step 2 if the password is entered incorrectly).	Input PASSWORD e.g. 1234
Step 4	Enter the number of the data record to be recalled (1 to 10) with the help of the numeric keypad or the rotary switch.	CALL 1
Step 5	Press the "ENTER" or the "OK" key in order to recall the selected data record. If the entered number does not lie within a range of 1 to 10, the display returns to step 2.	CALL *
The recall function can be exited at any time by pressing the ESC key.		

2.3.6 Menu Functions

The series 32K LSP-KONSTANTER is equipped with a menu driven operating mode for certain special functions. Menu driven operation is utilized as follows.

Procedure:	Operation	Display
Step 1	Press the "Menu" key.	→ MAX VOLTAGE SET MAX POWER SET
Step 2	Enter the password, or jump down to step 4 if the keypad is already enabled.	Input PASSWORD
Step 3	Press the "OK" key (the display returns to step 2 if the password is entered incorrectly).	Input PASSWORD xxxx
Step 4	Only one menu function can be displayed at a time. The various functions can be displayed and selected one after the other with the help of the up and down scroll keys, and can then be executed by pressing the "Enter" key.	<ul style="list-style-type: none"> ➤ MAX VOLTAGE SET ➤ MAX POWER SET ➤ ROTARY SW SET ➤ INITIAL OUT SET ➤ VOLT. SAVE SET ➤ BAUDRATE SET ➤ ADDRESS SET ➤ KEY LOCK ➤ CLEAR SAVE DATA ➤ Exit
The menu function can be exited at any time by pressing the ESC key.		

The menu functions are described in detail in the following sections.

2.3.6.1 Maximum Allowable Output Voltage

The maximum selectable output voltage can be specified with this function, in order to protect the power consumer from excessive voltage.

The following appears when MAX VOLTAGE SET is selected:

MAX VOLT = momentary V value NEW =	The voltage limit value can be set with the help of the numeric keypad or the rotary switch. The selected value is then acknowledged by pressing the "Enter" or the "OK" key.
---------------------------------------	---

2.3.6.1 Maximum Allowable Output Power

This function generates an acoustic warning signal if output power exceeds the selected value.

The following appears when MAX POWER SET is selected:

MAX POWER = momentary W value NEW = _	The power limit value can be set with the help of the numeric keypad or the rotary switch. The selected value is then acknowledged by pressing the "Enter" or the "OK" key. The maximum selectable value is 108 W.
--	--

If the selected value is exceeded, an acoustic signal is generated and "OP" appears at the display.

2.3.6.3 Enabling and Disabling the Rotary Switch

The following appears when Rotary SW SET is selected:

→ SW ENABLE (Def)
SW DISABLE

The selection can be changed with the help of the numeric keypad or the rotary switch, and the new selection is acknowledged by pressing the "Enter" key.

2.3.6.4 Output Status after Power-Up – Initial OUT SET

The output status which is active after the device is powered up can be selected with this function.

The following appears when INITIAL OUT SET is selected:

INI. OUT SAVE
→ INI. CLEAR (Def)

The selection can be changed with the help of the numeric keypad or the rotary switch, and the new selection is acknowledged by pressing the "Enter" key.

If INI. OUT SAVE is selected, the last selected output status (on or off) is saved to memory and is reused when the device is once again powered up. If INI. CLEAR (default setting) is selected, the output is always switched off when the device is powered up.

2.3.6.5 Save the Momentary Voltage Value – Voltage Save Set

This function stores the momentarily selected voltage value to memory, allowing the user to save a great deal of time. If this function is activated, the KONSTANTER is automatically set to the saved value when powered up.

The following appears when VOLT. SAVE SET is selected:

SAVE OUT VOLT.
→ DON'T SAVE (Def)

The selection can be changed with the help of the numeric keypad or the rotary switch, and the new selection is acknowledged by pressing the "Enter" key.

If SAVE VOLTAGE is selected, the last selected voltage value is stored to memory. If DON'T SAVE VOLT (default setting) is selected, this value is not stored to memory.

2.3.6.6 Transmission Speed Setting

This function is required when the power supply is operated with a PC.

The following appears when BAUDRATE SET is selected:

BAUDRATE 4800
BAUDRATE 9600
BAUDRATE 19 200
→ BAUT. 38 400 (Def)

Transmission speed can be changed with the help of the numeric keypad or the rotary switch. The new selection is acknowledged by pressing the "Enter" key. The default setting is 38,400 bps.

2.3.6.7 Selecting a Communication Address

Communication addresses are required for controlling systems with more than one power supply. Up to 32 devices can be controlled by a computer via the RS 232 / RS 485 bus. A unique address must be assigned to each power supply to this end.

The following appears when ADDRESS SET is selected:

ADDRESS SET = current address, e.g. 8 NEW = _
--

The address can be changed with the help of the up and down scroll keys or the rotary switch, and the new selection is acknowledged by pressing the "Enter" key. Addresses can be selected within a range of 0 to 31.

2.3.6.8 Disabling the Keypad

The numeric keypad can be disabled with this function, assuring reliable operation of the power supply.

The following appears when KEY LOCK is selected:

SET PASSWORD —

4 digits can be entered as a password with the help of the numeric keypad, or by turning the rotary switch and pressing the arrow keys. The password is confirmed by pressing the "ENTER" key.

After disabling the keypad, it can only be enabled again by entering the password and pressing the "OK" key.

If the user forgets his password, a reset can be executed with a master password. The master password is available upon request.

The output key is not effected by keypad disabling.

2.3.6.9 Deleting Saved Data Records

The following appears when CLEAR SAVE DATA is selected:

CLEAR 1

This function clears saved data. Each of the 10 data records must be deleted individually.

2.3.6.10 Exit Function

The menu function is exited when the exit function is selected.

Repair and Replacement Parts Service DKD Calibration Center* and Rental Instrument Service

If required please contact:

GMC-I Service GmbH
Service Center
Thomas-Mann-Str. 20
90471 Nuremberg, Germany
Phone: +49 911 8602-0
Fax: +49 911 8602-253
e-mail: service@gossenmetrawatt.com

This address is only valid in Germany. Please contact our representatives or subsidiaries for service in other countries.

* DKD-Calibration Laboratory for Electrical Quantities
DKD – K – 19701 accredited per DIN EN ISO/IEC 17025:2005

Accredited quantities: direct voltage, direct current value, direct current resistance, alternating voltage, alternating current value, AC active power, AC apparent power, DC power, capacitance, frequency, temperature

Competent Partner

GMC-I Gossen-Metrawatt GmbH is certified per DIN EN ISO 9001:2000.

Our DKD calibration lab is accredited by the Deutscher Kalibrierdienst (German Calibration Service) in accordance with DIN EN ISO/IEC 17025:2005 under registration number DKD–K–19701.

We offer a complete range of expertise in the field of metrology: from test reports and factory calibration certificates, right on up to DKD calibration certificates.

Our spectrum of offerings is rounded out with free test equipment management.

Our DKD calibration laboratory is part of our service department. If errors are discovered during calibration, our specialized personnel are capable of completing repairs using original replacement parts.

As a full service calibration lab, we can calibrate instruments from other manufacturers as well.

Product Support

If required please contact:

GMC-I Messtechnik GmbH
Product Support Hotline
Phone: +49 911-8602-0
Fax: +49 911-8602-709
e-mail: support@gossenmetrawatt.com

Operating Instructions for LSP-KONSTANTER Series 32K

Printed in Germany • Subject to change without notice

 **GOSSEN METRAWATT**
GMC-I Messtechnik GmbH
Südwestpark 15
90449 Nürnberg • Germany

Phone +49 911 8602-111
Fax +49 911 8602-777
E-mail info@gossenmetrawatt.com
www.gossenmetrawatt.com